

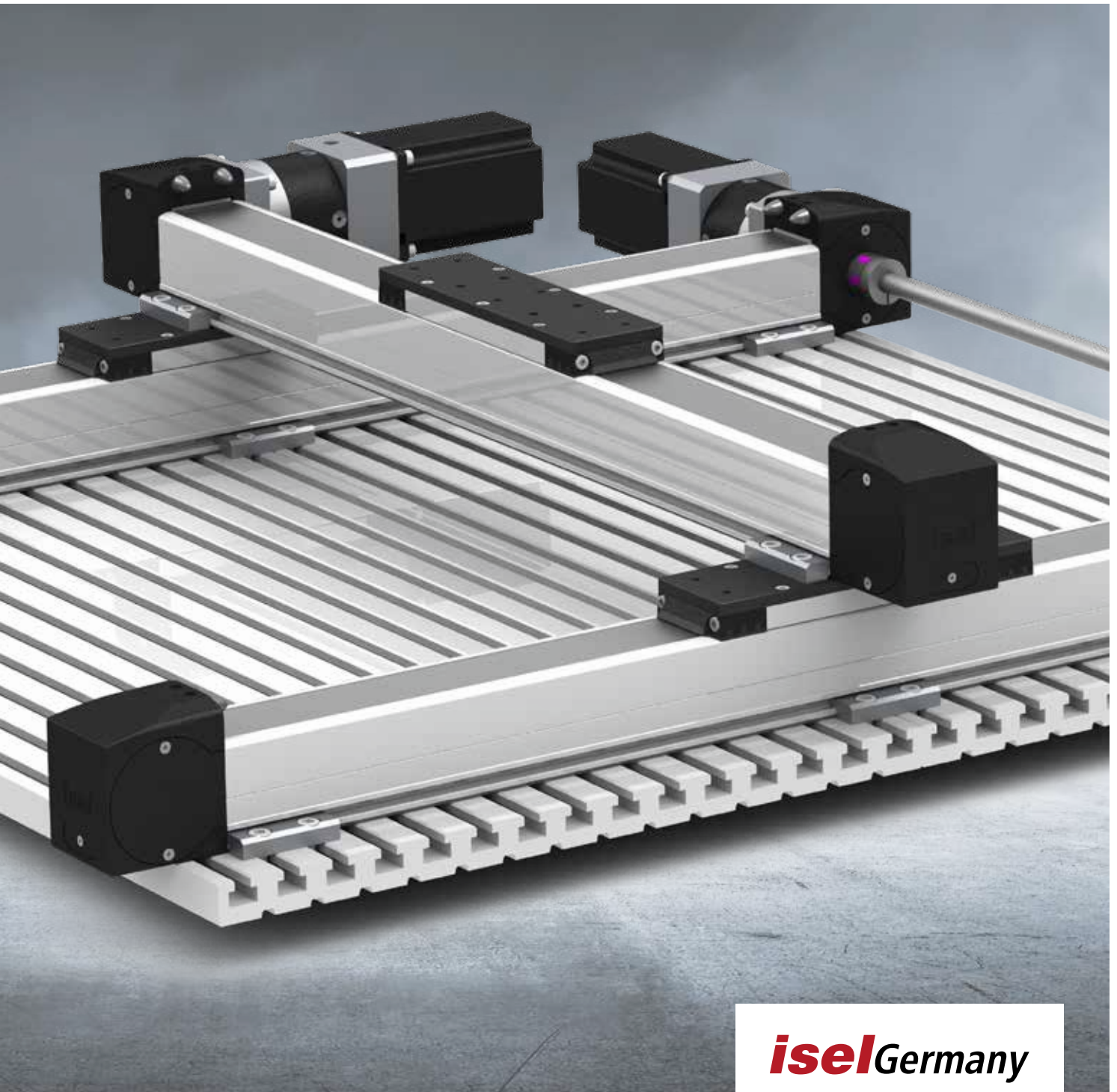

isel[®]
successful with
CNC TECHNOLOGY

COMPONENTS

for the automation



iselGermany

isel[®]

•• *successful with*
CNC TECHNOLOGY

Content

Locations isel Germany GmbH	5
Foreword and contact	6
Life cycle service	8

Mechanics

Linear units with spindle drive	12
Linear units with toothed belt drive	34
Linear guides	68
Ball screws spindles	92
Aluminum profiles	98

Electronics

CNC control panel	118
CNC controller	119
Drive controller(s)	124

Software

Control software	128
Automation software	130
OPC UA-Server	134
CAD-CAM software	136

Do you have questions about our components?
Then get in touch with our technical sales department.
Our technical sales department will provide you with
information about the individual components and,
if you wish, it will also make you an individual offer!

Phone: +49 (0) 6659 / 981-0
Email: info@isel.com





Plant in Eichenzell

36124 Eichenzell, Hesse
Total area: approx. 30,000 m²



Plant in Eiterfeld

36132 Eiterfeld, Hesse
Total area: approx. 52,000 m²



advanced
mechatronics

isel Germany is part of the stocklisted company Aalberts since february 2022. Since the inception in 1975, Aalberts is where technology matters and real progress can be made - humanly, financially and environmentally.

Greatness is made
of shared knowledge

Just like isel Germany, all Aalberts companies stand their ground in the engineering and technology world. As the world is changing rapidly and innovation cycles are reduced dramatically, the open and pragmatic internal culture at Aalberts helps us to exchange fresh thinking and to embrace new technologies.



Frank Schneider

Sales management

Tel.: +49 (0) 6659 / 981-489

Fax: +49 (0) 6659 / 981-776

frank.schneider@isel.com

Dear business partners,

it is very nice what you are interested in our company. We develop and manufacture **CNC machines** and **automation solutions** for a wide variety of requirements, industries and for customers all over the world - with a **modular approach**, diverse and open to technology. However, if you look more closely, our greatest strength lies in the detail – in our system units as well as in our process components. The **high degree of vertical integration and speed** as well as the quality of the components have always been our main factors leading to our success.

Precise linear technology, drive elements with high traversing and positioning accuracy, hardware, software and much more - with the developed **range of components** we can consequently offer you a customer-specific automation solution in a quick as well as flexible manner. We are **experts when it comes** to individual key components and at the same time we understand the big picture - since our quality standards are based on a deep understanding of the relationships between machine, tool, and process. And this is not just the case when standardized components are required, but also if our customers need the design of a special solution. We work in a customer-oriented manner and ensure a high level of flexibility offered by a medium-sized company.

Thanks to our **in-house** production guaranteed by a modern **CNC machine park** and the constant availability of almost all components, we are able to ensure **rapid**

processes when it comes to implementation. As our customer you will get everything from a single source: from the development and design to the manufacturing, delivery, assembly, commissioning, service, and documentation. In doing so we become the **preferred partner** for our customers. In addition, this permits us the economic implementation of extremely complex projects within a very short term.

In the course of our **50-year company history** which started in 1972 we have been building up a wide range of technology and engineering expertise across all industry boundaries. In addition, by setting up a partner program, we have succeeded in building up a powerful **competence network** in the fields of 3D printing, dosing and laser applications. Finally, this put us into the position of strengthening our position versus our competitors. Overall, the company isel Germany GmbH stands on a strong foundation being essential for its further development. This is the reason why we will continue to be a fundamental point of contact for our customers in the future when it comes to **automation** as well as to **Industry 4.0**.

Have lots of fun when you will plan your new automation solution, and discover the potential of your processes.

Frank Schneider

Sales team Germany



Steffan Gärtch
Technical sales
Components

Phone: +49 (0) 6659 / 981-773
Fax: +49 (0) 6659 / 981-776
steffan.gaerth@isel.com



Katja Henkel
Technical sales
Components

Phone: +49 (0) 06676 / 86792-744
Fax: +49 (0) 6659 / 981-777
katja.henkel@isel.com



Jessica Gatterdam
Team assistant

Phone: +49 (0) 6659 / 981-751
Fax: +49 (0) 6659 / 981-776
jessica.gatterdam@isel.com



Vanessa Irrgang
Team assistant

Phone: +49 (0) 06676 / 86792-563
Fax: +49 (0) 6659 / 981-777
vanessa.irrgang@isel.com

Contact | Advice | Support

Plant in Eiterfeld

isel Germany GmbH
Sachsenweg 8
D-36132 Eiterfeld

Plant in Eichenzell

isel Germany GmbH
Bürgermeister-Ebert-Straße 40
D-36124 Eichenzell

Headquarters in Eichenzell

Phone: +49 (0) 6659 / 981-700
Fax: +49 (0) 6659 / 981-776
info@isel.com

Customer Support

Phone: +49 (0) 6659 / 981-800
Fax: +49 (0) 6659 / 981-570
support@isel.com

Sales, order processing and head office

Mon to Thu 7:30 a.m. - 4:30 p.m.
Friday 7:30 a.m. - 2:00 p.m.

Dispatch and incoming goods

Mon to Thu 7:00 a.m. - 3:00 p.m.
Friday 7:00 a.m. - 12:30 p.m.

Self-collector

Mon to Thu 8:00 a.m. - 1:00 p.m.
Friday 8:00 a.m. - 11:00 a.m.

Application technique

Phone: +49 (0) 6659 / 981-790
Fax: +49 (0) 6659 / 981-776
anwendungstechnik@isel.com

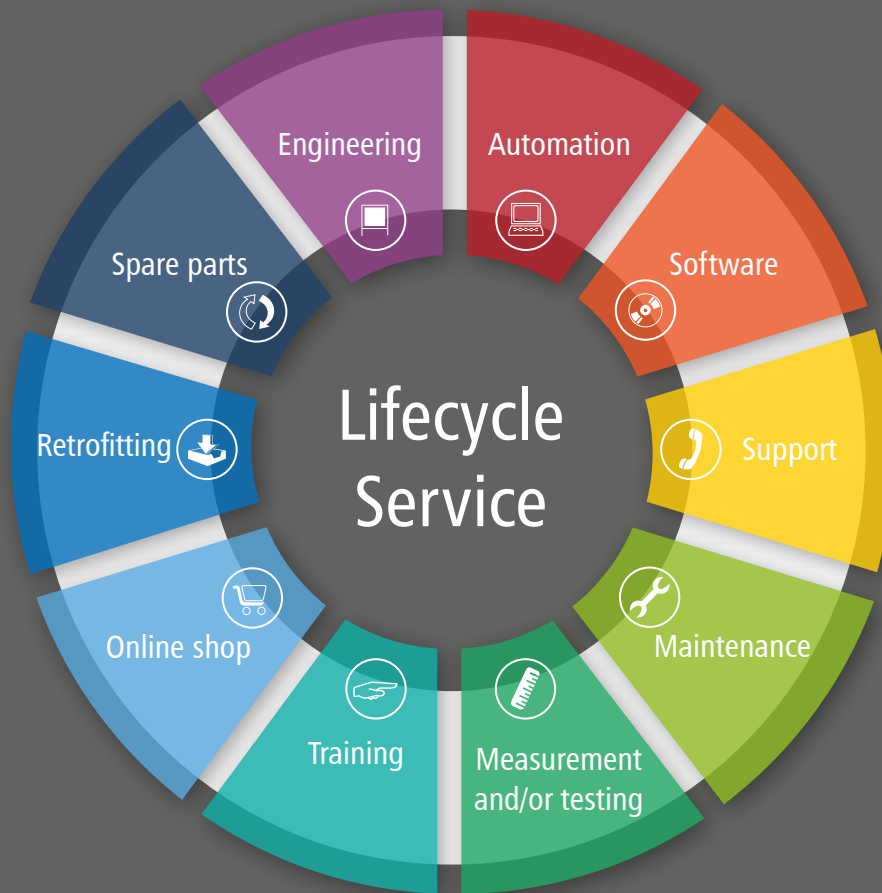

Excellent automation...



Thanks to the industrial communication protocol OPC - UA with its interface to our in-house software ProNC we will guide you on the way to Industry 4.0. By means of this interface, automation solutions by isel offer a completely automated remote control solution, intelligent data modelling and integrated security and authentication mechanisms.



From generation to generation...



we develop individual solutions for your automation-related tasks. Since every single automation solution is based on a high-performance software, by which the task at hand can be implemented quickly and conveniently. Thanks to our in-house post-processors by isel, we offer options in the field of the machine code generation by using a wide variety of CAD/CAM systems.



Competent support...



and free service with expert advice and, if necessary, the fastest possible troubleshooting, we offer you favorable maintenance contracts, telephone customer support, on-site troubleshooting as well as training and maintenance of your isel CNC machine. If you wish to commission your system on site, we are on hand with our service.



We know your machine...



and are professionals in the fields of care and maintenance, because nobody can afford a production downtime. We ensure that your isel product will always run in a reliable manner. The regular maintenance by our qualified service technicians ensures maximum accuracy and reliability - for the entire lifetime of the machine. We maintain your machine professionally, safely, and reliably.



Quality in industry & mechanical engineering



for more than four decades with extensive experience in automation and exclusive production in Germany. The components from isel, characterized by the label „made by isel“, guarantee trust and safety, reduce downtimes and thus significantly increase the throughput of the machines.

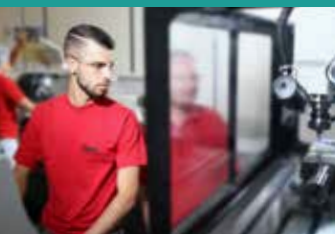

Training from a specialist...



for a smooth workflow with your CNC machine. We familiarise you with the software as well as with the system. In this manner, you can prevent downtimes and work in an efficient way. Train in our application centre on an identical CNC machine and get to know new functions and applications.



Open for you around the clock!



From A (Aluminiumprofil, aluminium profile) to Z (Zahnriemenantrieb, toothed belt drive): The isel online shop offers not only components for automation, but also complete CNC systems. Free download of CAD data, technical data sheets and operating instructions complete our range - just take a look on our website www.isel.com



We are upgrading...



so that your CNC machines remain state-of-the-art at any time. We would be very glad to offer you upgrade options which are individually tailored to your CNC system.



If a replacement is required...



Our specialists will be glad to support you with your spare parts order. We supply you with the mechanical, electronic, and pneumatic spare parts for your machine in an uncomplicated and cost-effective manner. If you need any help for the installation, just give us a call.



Our engineering team...



will be happy to implement mechanical and electronic designs as well as software adaptations for your automation task. Adaptations to axis and rotation units as well as control cabinet configurations with risk assessments and documentation services are no problem for us. Individual programming in CNC and PLC environments is solved by the team according to the respective requirements.

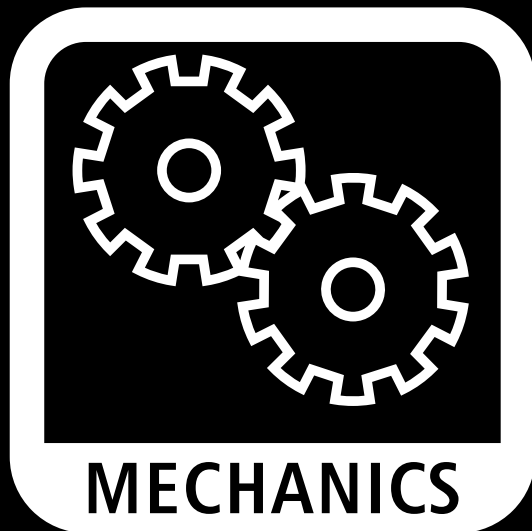
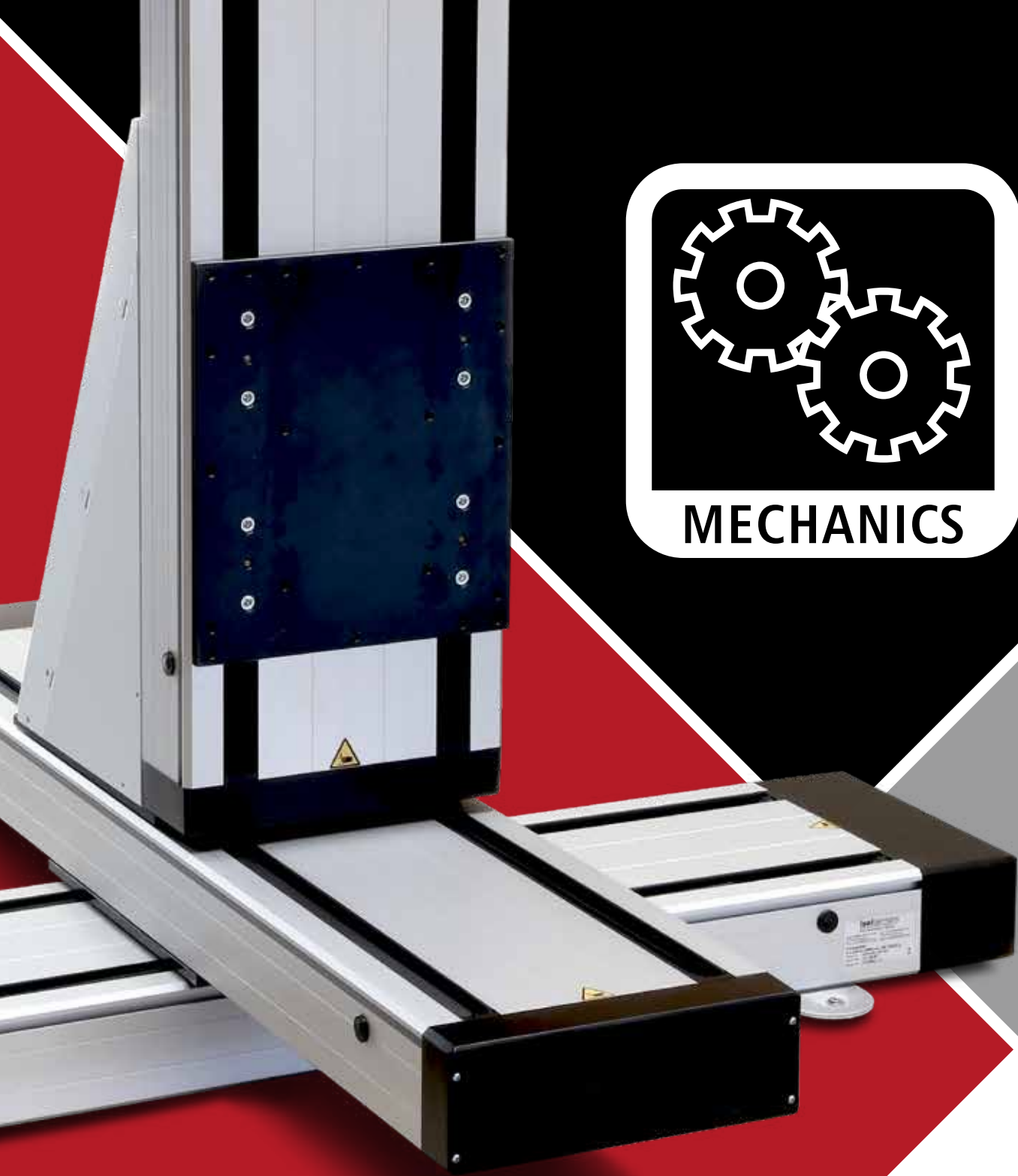

MECHANICS

Linear units with spindle drive

Linear unit is equipped with spindle drive iLE 20/20	14
Linear unit equipped with spindle drive LES 4	16
Linear unit equipped with spindle drive LES 5	18
Linear unit is equipped with spindle drive LES 6	20
Mounting kit is equipped with bevel gear	22
Engine modules	24
Motor pin assignments	26
Motor leads	27
Accessories LES	28
Connection angle WV	29
Connection angle WV	30
Connection angle WV	31
Slide plates PS	32
Slide plates PS	33

Linear units with toothed belt drive

Linear unit equipped with toothed belt drive LEZ 4G	36
Linear unit equipped with toothed belt drive LEZ 1	40
Linear unit equipped with toothed belt drive LEZ 2	42
Linear unit equipped with toothed belt drive LEZ 3	44
Accessories LEZ	46

Rotation & rotary axes

Rotary indexing table/rotary axis RDH-XS	50
Rotary indexing tables/rotary axis RDH-S	52
Rotary indexing tables/rotary axis RDH-M	54
Rotary swivel unit type DSH-S	60
Rotary swivel unit type DSH-M	62
Rotary axis type ZD30	64
Mini rotary axis type MD 1	66

Linear guides

Aluminum shaft slide	68
Load capacity and life-time	69
Linear guide rail type LFS-8-1 / LFS-8-2	70
Linear guide rail type LFS-8-3	72
Linear guide rail type LFS-8-4	74
Linear guide rail type LFS-8-7	76
Linear guide rail type LFS-12-1	78
Linear guide rail type LFS-12-11	80
Linear guide rail type LFS-12-2	82
Linear guide rail type LFS-12-3	84
Linear guide rail type LFS-12-10	86
T-slot accessories	88
Profile rail guide type PSF 15, 20, 25 and 30	90

Ball screws spindles

Ball screw spindles \varnothing 12, 16, 20, 25 mm	94
Flange bearing	95
Ball screw nuts equipped with single thread return	96

Aluminum profiles

Panel profiles PP 50 - PP 250	100
Universal profiles PU 25 / PU 50	101
T-slot plates PT 25	102
T-slot plates PT 50	103
Rectangular profiles type RE 40	104
Rectangular profiles type RE 65	105
Lightweight frame profiles PL 40 / PL 80	106
Rectangular profiles PS 50 / PS 80	107
Stand profiles HP 100 / HP 140	108
Working tables AT 1 / AT 2 / AT 3	109
Accessories	112

isel[®]

 *successful with*
CNC TECHNOLOGY



Designed for such tasks as simple and highly dynamic ones

Linear units are starting to become increasingly crucial as production as assembly processes continue to be automated. Linear units, which are equipped with a spindle drive, are mostly used only when high axial thrust and high level of accuracy are required. Each movement task demands an individual technically adequate solution to ensure the optimal level in terms of economic success.

Many linear units, which are equipped with spindle drives, are based on aluminum guide rails with rigid precision steel shafts that are combined with ball-guided shaft slides. You should trust a plug-in solution that can be integrated into the current technical system, or have a suitable linear system designed with all the necessary components for your application. The range of accessories offers you freedom when creating designs of individual design ideas.

Functional overview based on example LES 5

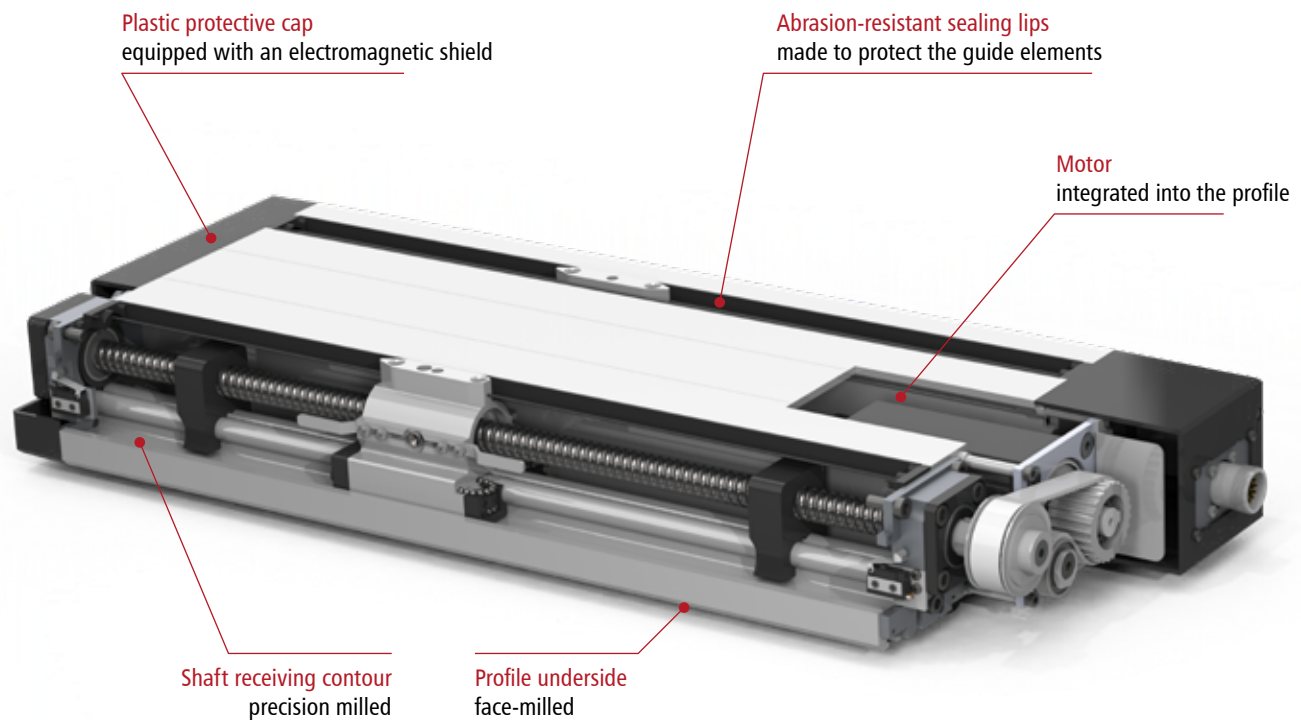

- End position buffering on 2 sides with soft PVC parabolic springs
- Counter bearing equipped with 2 needle sleeves



- Spindle support starting from a profile length of 1,500 mm done without restricting the travel range



- Circulation of the ball inside the patented aluminum linear slide
- Glass-fiber reinforced deflection parts equipped with scrapers



- Clearance-free ball screw nut equipped with scrapers
- Central lubricating device for ball screw nut and circulations



- Integrated overrun limit switch
- Spindle bearing equipped with angular ball bearings
- Axial position without clearance due to self-locking special slotted nut



- Belt deflection and connection electronics fully covered by the protective cap



Z-lift arrangement
three axes equipped with cross table
platforms and connecting brackets



Flatbed arrangement
Gantry operation ensured by three axis

- 1 **H-construction** with two axis
- 2 **Configuration of the boom** with two axes
- 3 **Configuration of the lifting boom** with three axes
- 4 **Configuration of the portal** with four axis
- 5 **Configuration of the flat bed** with five axis

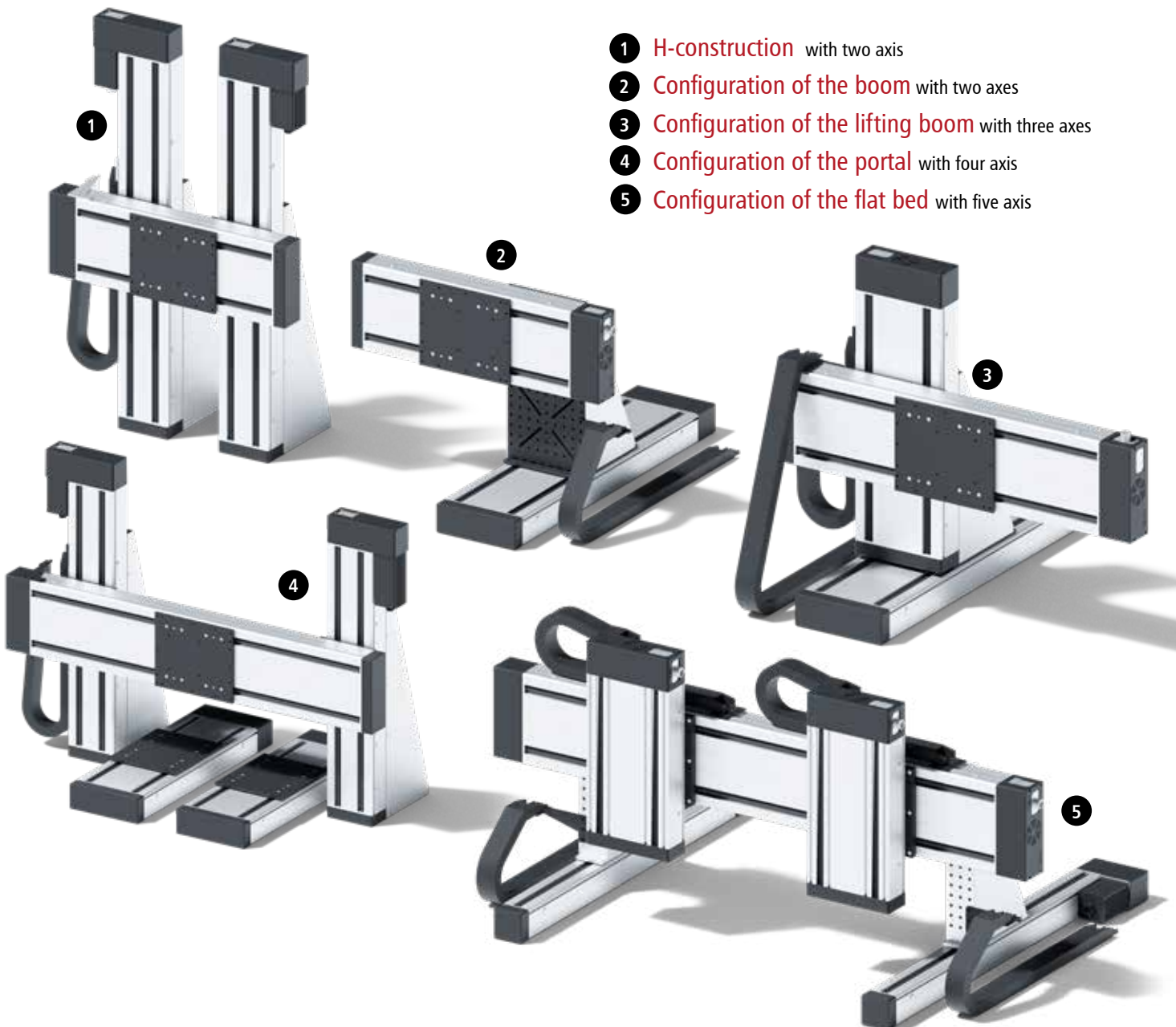



Linear unit is equipped with spindle drive iLE 20/20

The LES 5 undergoes the complete development! Two drives - one axis

With the linear unit, there is the possibility of incorporating two independent linear movements in simply one unit by installing two ball screw spindles. Therefore, 2 linear movements' realization is made possible with the smallest dimensions.

The linear units can be purchased with either one or two integrated ball screw drives (Ø 20 mm), pitches of either 5/10/20/40 mm, and with 2, 4 or 6 aluminum clamping plates.

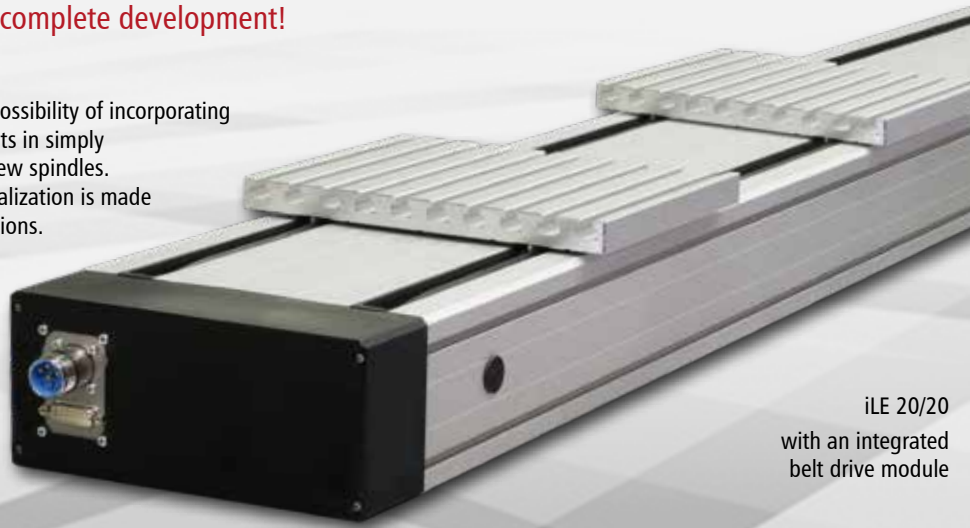

iLE 20/20 with an integrated belt drive module

- Aluminum shaft mounting profile, anodized
- Milled clamping surface
- 20 precision steel rails equipped with steel slides
- Profile sealing is equipped with abrasion-resistant sealing lips
- 2 limit and reference switches
- Repeatability +/- 0.02 mm

Options

- Stepping or servo motor

Technical data

Moment of inertia Ix	705 cm ⁴
Moment of inertia Iy	2,807 cm ⁴
Centre of the area	39.5 mm
Cross-sectional area	54.22 cm ²
Material	EN AW-6060 T66
Anodizing	E6/EV1
Weight equipped with steel rail guide	20.6 kg/m
Weight equipped with both steel rail guide and ball screw spindle	22.8 kg/m

Deflection

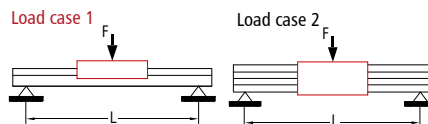
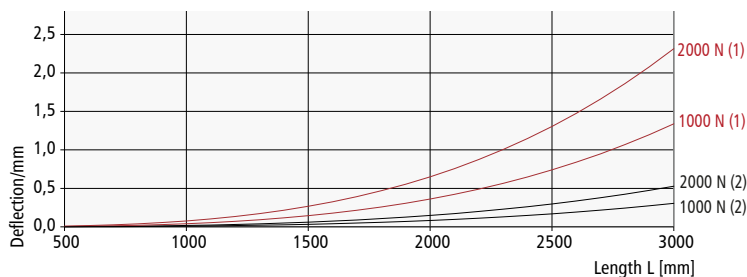

Order key

238 XXX XXXX

Drive	Steel slide	Profile lengths
2 = integrated belt drive module	1 = 2 slides	e.g. 0029 = 290 mm (min.)
3 = preparation direct drive module	2 = 4 slides	0389 = 3,890 mm (max.)
	3 = 6 slides	Ball screw drive
	4 = 8 slides	0 = without
		3 = gradient 5 mm
		4 = gradient 10 mm
		5 = gradient 20 mm
		6 = gradient 40 mm

Version equipped with two spindles on demand.



iLE 20/20 installed with direct drive



Dimensional drawing

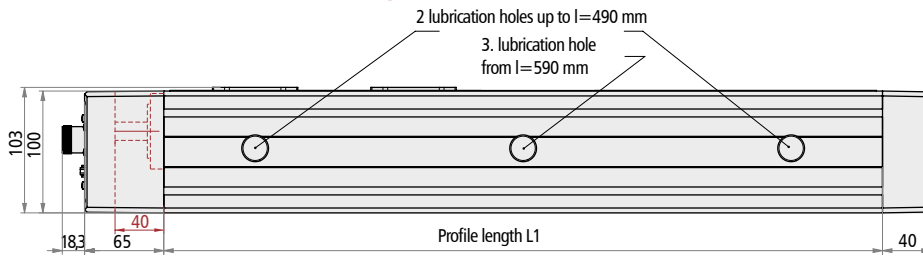

Length of stroke

with 2 x steel slides	L1-150 mm
with 4 x steel slides	L1-280 mm

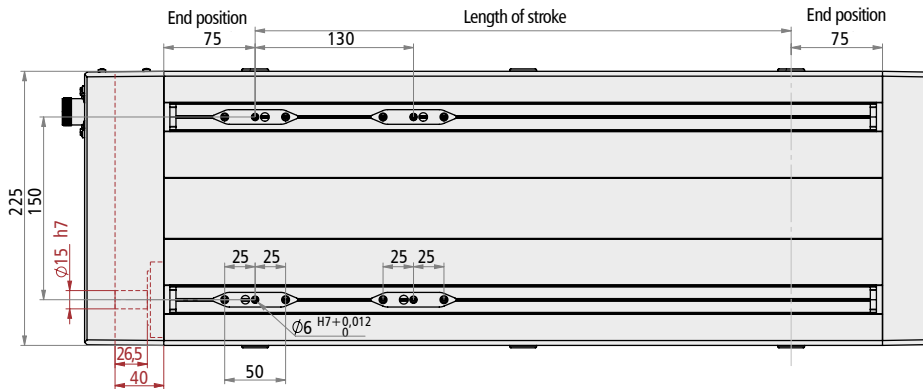

integrated belt drive module



direct drive module

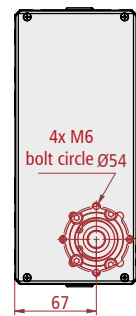

Aluminium profile

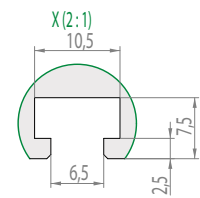
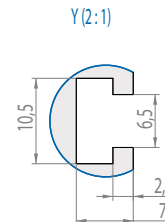
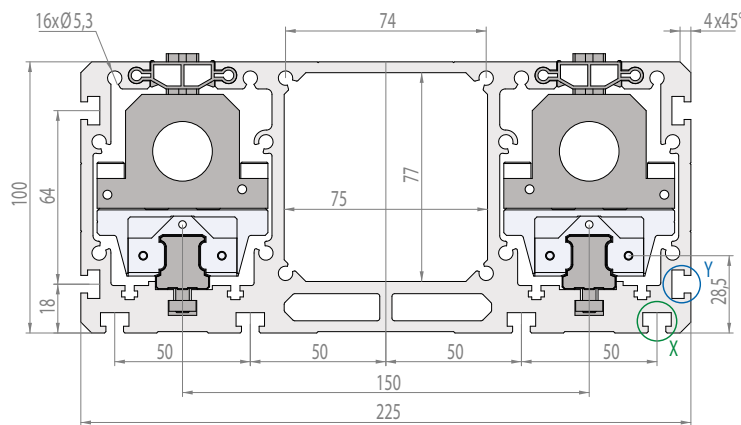

Load data

Permissible spindle speeds

ball screw spindle $\phi 20$ mm, equipped with fixed-loose bearing

Profile length [mm]	Spindle gradient p [mm]			
	5	10	20	
	max. permissible Spindle speed n permissible [1/min]	maximum permissible Feed speed v permissible [mm/s]		
490	6,000	500	1,000	2000
990	4,000	333	667	1,333
1,390	2,000	167	333	667
1,490*	4,000	333	667	1,333
1,990*	2000	167	333	667
2,490*	1500	125	250	500
2,990*	1,000	83	167	333
3,490*	700	58	117	233

*equipped with spindle support

Number of slides	2	4
C_0	40,020 N	60,000 N
C	22,811 N	34,200 N
$F1_{stat}$	40,020 N	60,000 N
$F1_{dyn}$	22,811 N	34,200 N
$F2_{stat}$	40,020 N	60,000 N
$F2_{dyn}$	22,811 N	34,200 N
$M0_x$	3,002 Nm	4,500 Nm
$M0_y$	800 Nm	3,900 Nm
$M0_z$	800 Nm	3,900 Nm
M_x	1,711 Nm	3,422 Nm
M_y	456 Nm	2,223 Nm
M_z	456 Nm	2,223 Nm

$$Fr(\alpha) = \frac{F_2}{\cos \alpha}$$

$$Fr(\alpha) = \frac{F_1}{\sin \alpha}$$

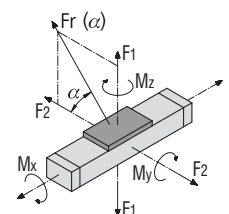



Linear unit equipped with spindle drive LES 4

- Aluminum shaft mounting profile W 75 x H 75 mm, and it is also naturally anodized
- Clamping surface and underside of milled profile
- Equipped with 2 precision steel shafts $\varnothing 12$ h6, material Cf53, and hardness of 60 ± 2 HRC
- Aluminum shaft slide WS 5/70 or 2 x WS 5/70 (L 70 mm), adjustable without clearance, centered Lubrication
- Ball screw drive equipped with 2.5 / 4 / 5 / 10 / 20 mm gradient
- Profile sealing equipped with abrasion-resistant sealing lips
- Die-cast aluminum endplates
- Equipped with 2 limit and/or reference switches, with a repeat accuracy of ± 0.02 mm
- Sealed angular contact ball placed inside of the drive steel flange

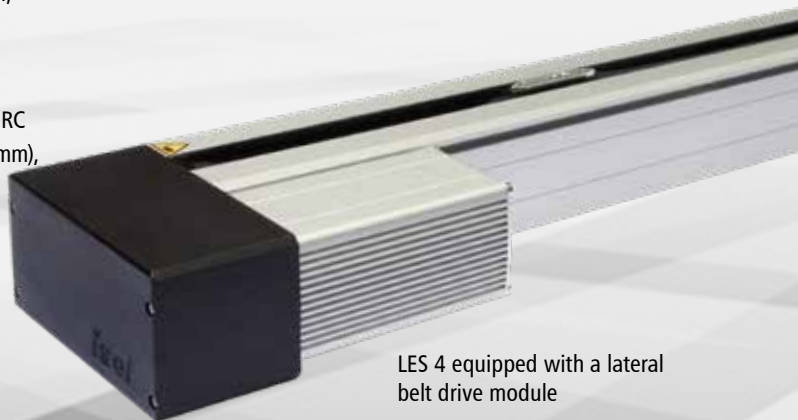

LES 4 equipped with a lateral belt drive module

Options

- Black anodized aluminum profile
- Electromagnetic brake located inside the motor module or as extension of the drive spindle
- Steel slide
- Mounting kit equipped with an external limit switch (see accessories)

Upon request:

- Length measurement system
- Bellows cover
- Assembly on the left side of the motor module

Technical data

Aluminum profile LES 4	
Moment of inertia I_x	107.711 cm ⁴
Moment of inertia I_y	125.843 cm ⁴
Center of gravity (see dimensional drawing)	33.23 mm
Cross-sectional area	18.81 cm ²
Material	AlMgSiO, 5F22
Anodizing	E6/EV1
Weight with steel shafts	6.2 kg/m
Weight with both steel shafts and spindles	7.6 kg/m

Deflection

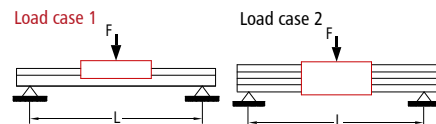
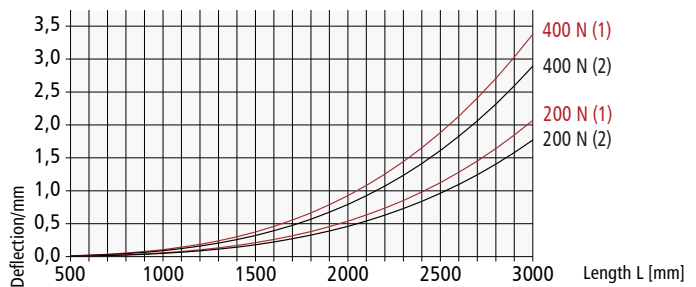

No load torques [Ncm]

Torque (1/min)	Spindle gradient				
	2.5	4	5	10	20
500	15	15	16	17	18
1,500	19	19	19	20	21
3,000	23	24	24	25	26

Order key

234 XXX 0XXX

Drive
 0 = Preparation of direct drive module
 1 = Preparation of belt drive module

Linear guide slide
 0 = 1 slide 70 mm
 1 = 1 slide 200 mm
 2 = 2 slides 70 mm

Ball screw drive
 0 = without
 1 = gradient 2.5 mm
 2 = gradient 4 mm
 3 = gradient 5 mm
 4 = gradient 10 mm
 5 = gradient 20 mm
 6 = gradient 20 mm (equipped with return of the ball)

Profile lengths (L1)*
 e.g. 029 = 290 mm (min.)
 349 = 3490 mm (max.)

*The data is shortened by the last digit.
 Ordering standard profile lengths can be done in 100 mm increments.



LES 4 installed with direct drive



Dimensional drawing

Length of stroke
 with 1 x WS 5/70 = L1 -150 mm
 with 2 x WS 5/70 = L1 -280 mm

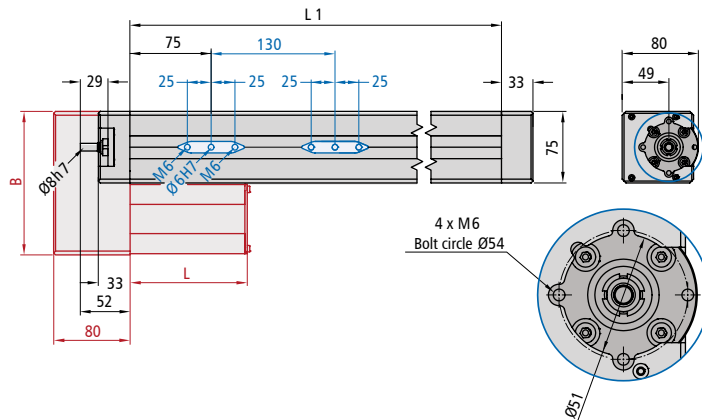

Aluminium profile

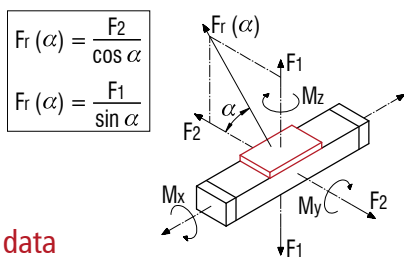
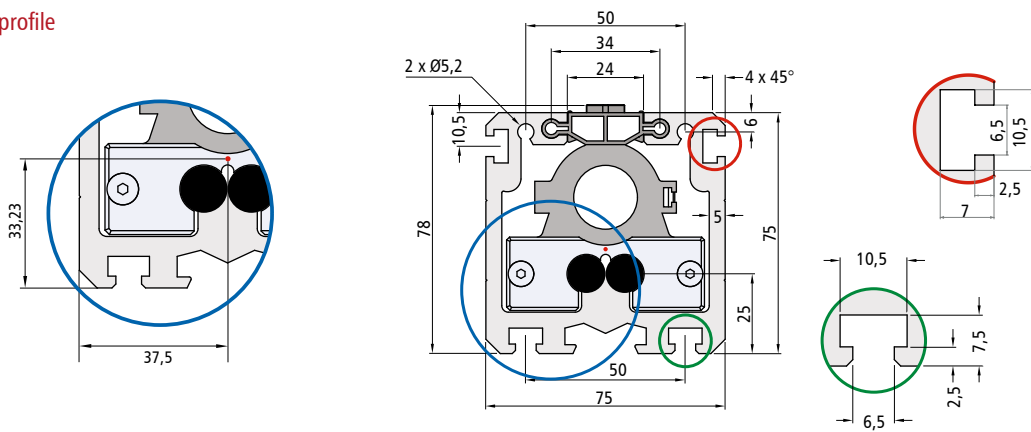

Load data

LES 4 with a WS 5/70		LES 4 with two WS 5/70	
C ₀	2577 N	C ₀	5153 N
C	1461 N	C	2319 N
F ₁ static	2201 N	F ₁ static	4401 N
F ₁ dynamic	1248 N	F ₁ dynamic	1981 N
F ₂ static	2577 N	F ₂ static	5153 N
F ₂ dynamic	1461 N	F ₂ dynamic	2319 N
M _x static	31 Nm	M _x static	46 Nm
M _y static	82 Nm	M _y static	182 Nm
M _z static	96 Nm	M _z static	213 Nm
M _x dynamic	14 Nm	M _x dynamic	21 Nm
M _y dynamic	47 Nm	M _y dynamic	82 Nm
M _z dynamic	55 Nm	M _z dynamic	96 Nm

permissible spindle speeds

LES 4 Profile length L [mm]	Spindle gradient p [mm] maximum per- missible Spindle speed n perm. [1/min]	2.5	4	5	10	20
		maximum permissible Feed speed v perm. [mm/s]				
490	4,000	167	267	333	667	1333
990	3,000	125	200	250	500	1000
1,390	1,500	63	100	125	250	500
1,490*	3,000	125	200	250	500	1000
1,990*	1,650	69	110	138	275	550
2,490*	1,050	44	70	88	175	350
2,990*	750	31	50	63	125	250

*equipped with spindle support



Linear unit equipped with spindle drive LES 5

- Aluminum shaft mounting profile W 225 x H 75 mm, and it is also naturally anodized
- Milled clamping surface and underside of profile
- Equipped with 4 precision steel shafts $\varnothing 12$ h6, material Cf53, and hardness 60 ± 2 HRC
- Aluminum shaft slide WS 5/70 or 2 x WS 5/70 (L 70 mm), adjustable without clearance, centered Lubrication
- Ball screw drive equipped with 2.5 / 4 / 5 / 10 / 20 mm gradient
- Profile sealing by abrasion-resistant sealing lips
- Die-cast aluminum endplates
- Equipped with 2 limit and/or reference switches, with a repeat accuracy of ± 0.02 mm
- Sealed angular contact ball placed inside of the drive steel flange



LES 5 equipped with an integrated belt drive module

Options

- Black anodized aluminum profile
- Electromagnetic brake located inside the motor module or as extension of the drive spindle
- Steel slide
- End limit switch equipped with mounting-kit (see accessories)

Upon request

- Length measurement system
- Bellows cover

Deflection

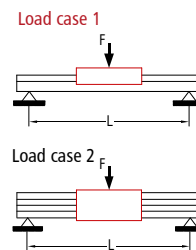
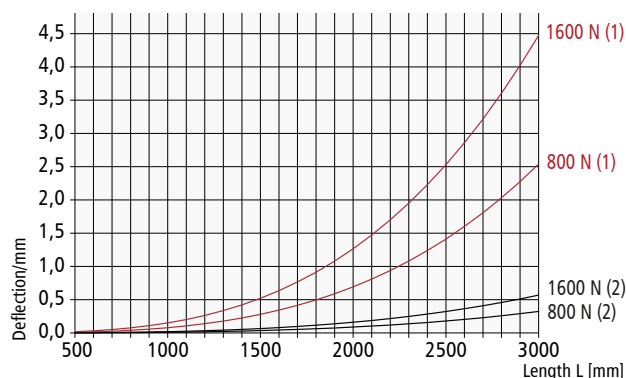

Technical data

Aluminum profile LES 5	
Moment of inertia I_x	2361,654 cm ⁴
Moment of inertia I_y	298,925 cm ⁴
Center of gravity (see dimensional drawing)	33.39 mm
Cross-sectional area	42.49 cm ²
Material	AlMgSiO, 5F22
Anodizing	E6/EV1
Weight with steel shafts	13.8 kg/m
Weight with both steel shafts and spindles	15.2 kg/m

No load torques [Ncm]

Torque (1/min)	Spindle gradient				
	2.5	4	5	10	20
500	15	15	16	17	18
1,500	19	19	19	20	21
3,000	23	24	24	25	26

Order key

234 XXX 0XXX

Profile lengths (L1)*
e.g. 029 = 290 mm (min.)
349 = 3490 mm (max.)

Drive
3 = Preparation of direct drive module
4 = Preparation of belt drive module

Linear guide slide
0 = 2 slides 70 mm
1 = 2 slides 200 mm
2 = 4 slides 70 mm

Ball screw drive
0 = without
1 = gradient 2.5 mm
2 = gradient 4 mm
3 = gradient 5 mm
4 = gradient 10 mm
5 = gradient 20 mm
6 = gradient 20 mm (equipped with return of the ball)

*The data is shortened by the last digit.
Ordering standard profile lengths can be done in 100 mm increments.

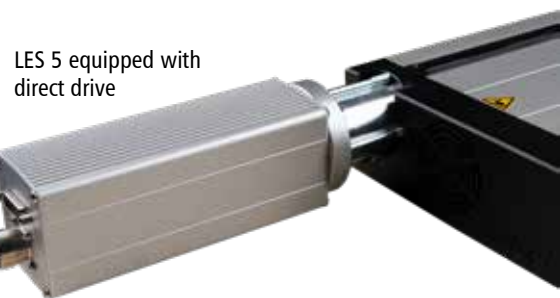

LES 5 equipped with direct drive



Dimensional drawing

Length of stroke
 with 2 x WS 5/70 = L1 -150 mm
 with 4 x WS 5/70 = L1 -280 mm

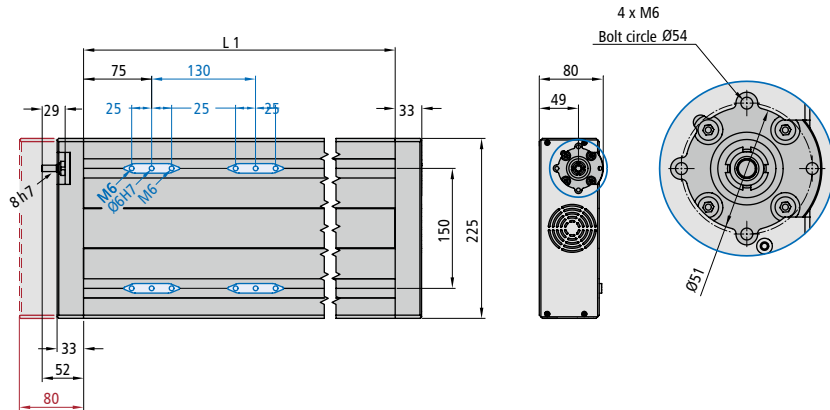

Aluminium profile

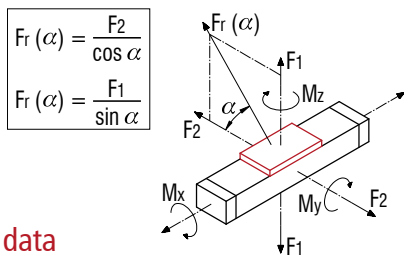
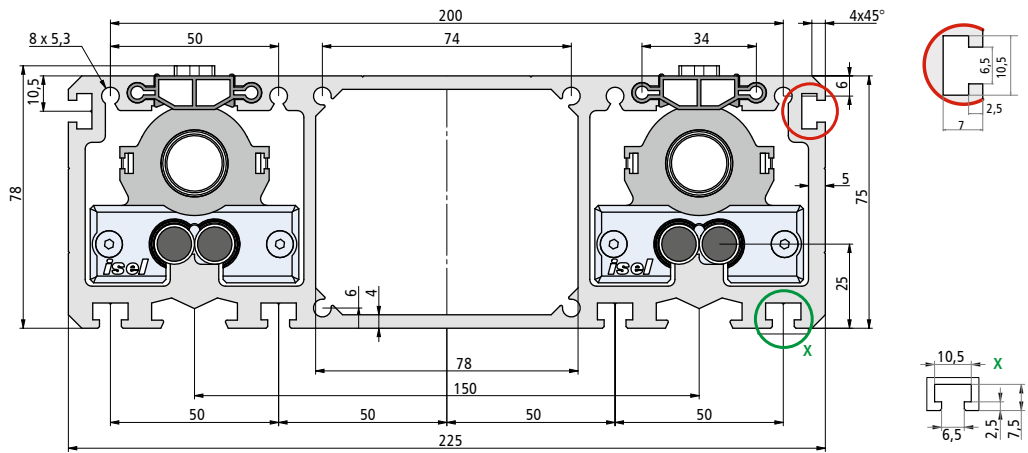

Load data

LES 5 with two WS 5/70		LES 5 with four WS 5/70	
C ₀	5153 N	C ₀	6606 N
C	2319 N	C	3746 N
F ₁ static	4401 N	F ₁ static	5642 N
F ₁ dynamic	1981 N	F ₁ dynamic	3198 N
F ₂ static	5153 N	F ₂ static	6606 N
F ₂ dynamic	2319 N	F ₂ dynamic	3746 N
M _x static	377 Nm	M _x static	423 Nm
M _y static	164 Nm	M _y static	367 Nm
M _z static	192 Nm	M _z static	429 Nm
M _x dynamic	169 Nm	M _x dynamic	240 Nm
M _y dynamic	74 Nm	M _y dynamic	208 Nm
M _z dynamic	87 Nm	M _z dynamic	243 Nm

permissible spindle speeds

LES 5 Profile length L [mm]	Spindle gradient p [mm] maximum permissible Spindle speed n perm. [1/min]	2.5	4	5	10	20
		maximum permissible Feed speed v perm. [mm/s]				
490	4,000	167	267	333	667	1333
990	3,000	125	200	250	500	1000
1,390	1,500	63	100	125	250	500
1,490*	3,000	125	200	250	500	1000
1,990*	1,650	69	110	138	275	550
2,490*	1,050	44	70	88	175	350
2,990*	750	31	50	63	125	250

*equipped with spindle support



Linear unit is equipped with spindle drive LES 6

- Aluminum shaft mounting profile W 150 x H 75 mm, naturally anodized
- Clamping surface and underside of milled profile
- Equipped with 4 precision steel shafts Ø 12 h6, material Cf53, and hardness 60 ± 2 HRC
- Aluminum shaft slide WS 5/70 or 2 x WS 5/70 (L 70 mm), adjustable without clearance, centered Lubrication
- Ball screw drive equipped with 2.5 / 4 / 5 / 10 / 20 mm gradient
- Profile sealing equipped with abrasion-resistant sealing lips
- Die-cast aluminum endplates
- Equipped with 2 limit and/or reference switches, with a repeat accuracy of ± 0.02 mm
- Sealed angular contact ball placed inside of the drive steel flange



LES 6 is equipped with side belt drive module

Options

- Black anodized aluminum profile
- Electromagnetic brake located inside the motor module or as extension of the drive spindle
- Steel slide
- End limit switch equipped with mounting-kit (see accessories)

Upon request

- Length measurement system
- Bellows cover
- Assembly on the left side of the motor module

Deflection

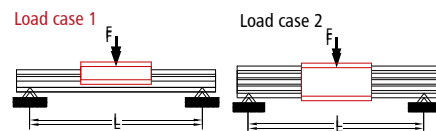
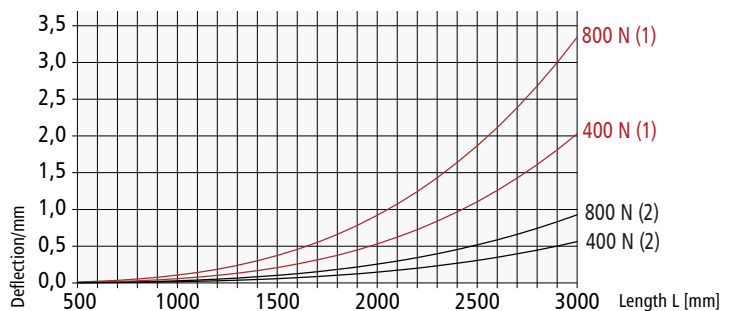

Technical data

Aluminum profile LES 6	
Moment of inertia I_x	707,100 cm ⁴
Moment of inertia I_y	212,200 cm ⁴
Center of gravity (see dimensional drawing)	32,78 mm
Area	30,07 cm ²
Material	AlMgSiO, 5F22
Anodizing	E6/EV1
Weight with steel shafts	11.4 kg/m
Weight with both steel shafts and spindles	12.8 kg/m

No load torques [Ncm]

Torque (1/min)	Spindle gradient				
	2.5	4	5	10	20
500	17	17	18	20	21
1,500	20	20	22	24	25
3,000	24	25	26	26	30

Order key

234 XXX 0XXX

Drive
6 = Preparation of direct drive module
7 = Preparation of belt drive module

Linear guide slide
0 = 2 slides 70 mm
1 = 2 slides 200 mm
2 = 4 slides 70 mm

Ball screw drive
0 = without
1 = gradient 2.5 mm
2 = gradient 4 mm
3 = gradient 5 mm
4 = gradient 10 mm
5 = gradient 20 mm
6 = gradient 20 mm (equipped with return of the ball)

Profile lengths (L1)*
 E:G: **029** = 290 mm (min.)
349 = 3490 mm (max.)

*The data is shortened by the last digit.
 Ordering standard profile lengths can be done in 100 mm increments.

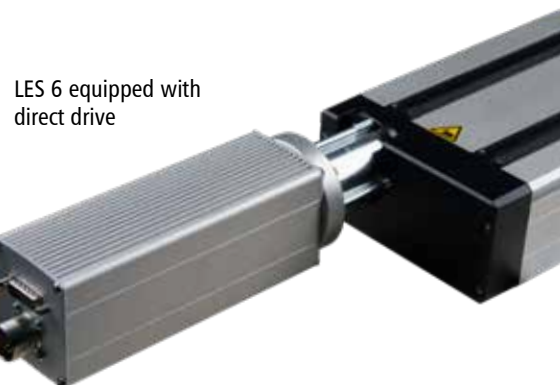

LES 6 equipped with direct drive



Dimensional drawing

Length of stroke
 with 2 x WS 5/70 = L1 -150 mm
 with 4 x WS 5/70 = L1 -280 mm

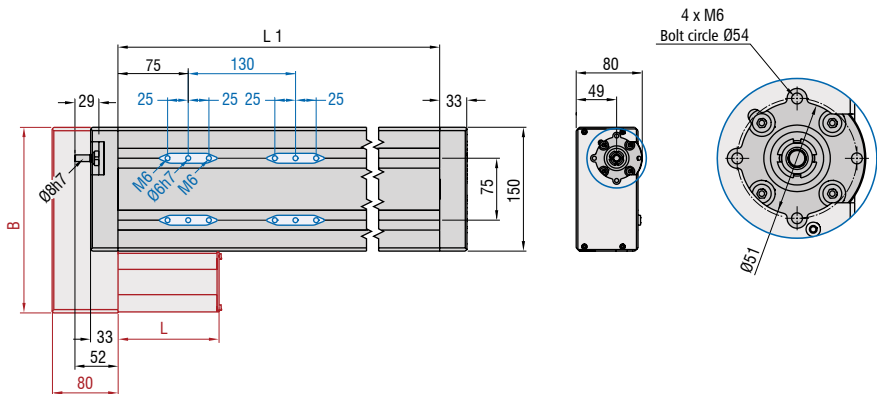

Aluminium profile

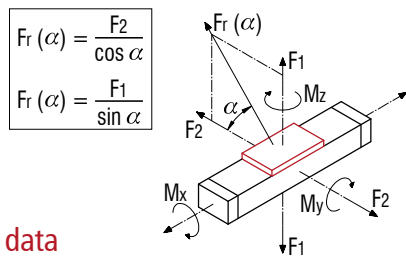
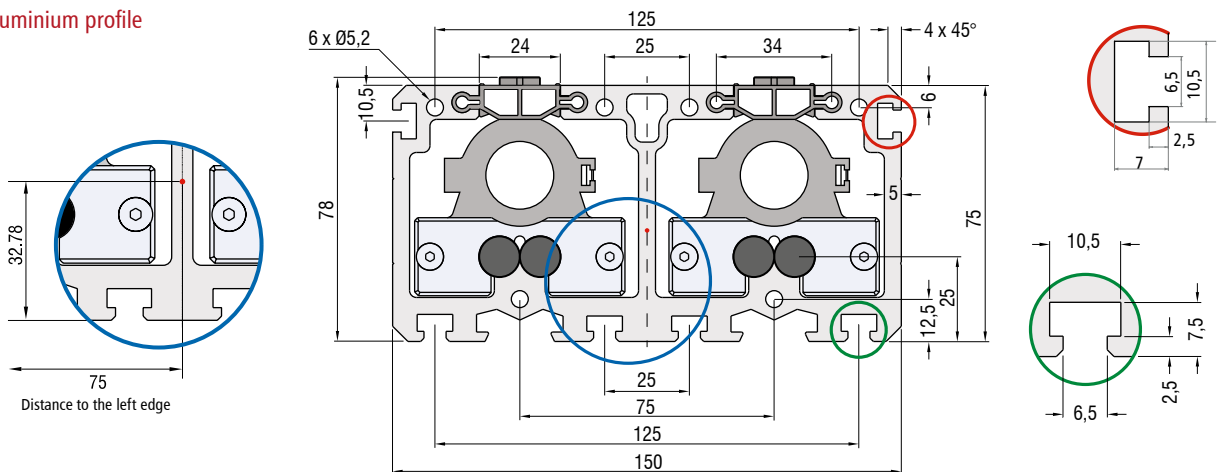

Load data

LES 6 with two WS 5/70		LES 6 with four WS 5/70	
C ₀	5153 N	C ₀	6606 N
C	2319 N	C	3746 N
F ₁ static	4401 N	F ₁ static	5642 N
F ₁ dynamic	1981 N	F ₁ dynamic	3198 N
F ₂ static	5153 N	F ₂ static	6606 N
F ₂ dynamic	2319 N	F ₂ dynamic	3746 N
M _x static	212 Nm	M _x static	212 Nm
M _y static	164 Nm	M _y static	367 Nm
M _z static	192 Nm	M _z static	429 Nm
M _x dynamic	95 Nm	M _x dynamic	120 Nm
M _y dynamic	74 Nm	M _y dynamic	208 Nm
M _z dynamic	87 Nm	M _z dynamic	243 Nm

permissible spindle speeds

LES 6 Profile length L [mm]	Spindle gradient p [mm] maximum per- missible Spindle speed n perm. [1/min]	2.5	4	5	10	20
		maximum permissible Feed speed v perm. [mm/s]				
490	4,000	167	267	333	667	1333
990	3,000	125	200	250	500	1000
1,390	1,500	63	100	125	250	500
1,490*	3,000	125	200	250	500	1000
1,990*	1,650	69	110	138	275	550
2,490*	1,050	44	70	88	175	350
2,990*	750	31	50	63	125	250

*equipped with spindle support



Mounting kit is equipped with bevel gear



- 1 Angle drives
- 2 split clutch housing is equipped with shaft coupling WK 40/60
- 3 LES 4, LES 6 or LES 5 (preparation of direct drive)
- 4 Coupling for transmission shaft Ø25
- 5 Transmission shaft Ø25
- 6 The procedure of pillow block bearing is recommended from a transmission wavelength of 1500 mm

Installation options

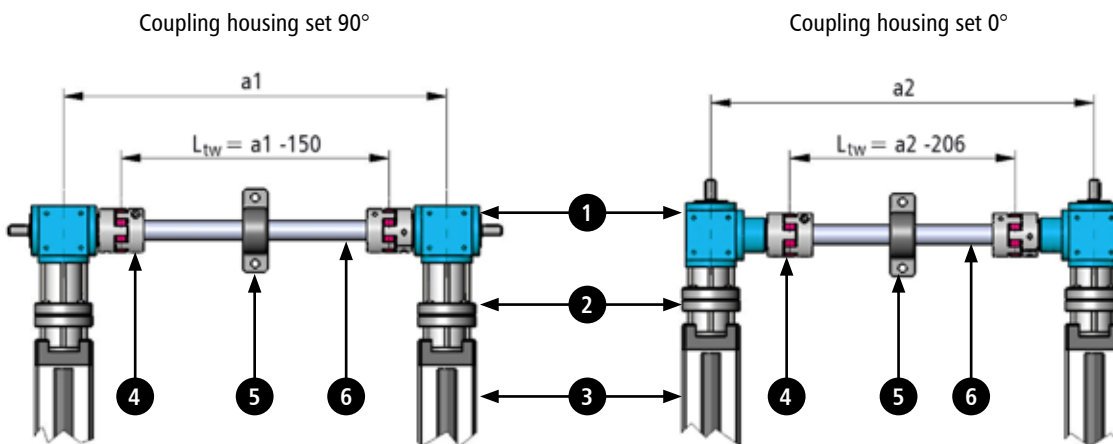

Order data

Mounting kit is equipped with bevel gear

It is equipped with H-construction LES 4 / LES 6 / LES 5, Mounting 0°

Scope of delivery: 2x 1, 2x 2, 2x 4
Item-Number: 216150 0001

In case of an H-construction for LES 4 / LES 6 / LES 5, Fastening 90°

Scope of delivery: 2x 1, 2x 2, 2x 4
Part No.: 216150 0002

Transmission shaft

Hollow shaft of Ø 25 mm x 4 mm, blank 1000 mm
Part No.: 219001 0125

Hollow shaft of Ø 25 mm x 4 mm, blank 2000 mm
Part No.: 219001 0225

Coupling/Pillow Bearing

Coupling for transmission shaft
Conversion is done from 12 to 25 mm, 2 pcs.
Part No.: 218050 0002

Pillow bearing for the transmission shaft
PU 1 piece
Part No.: 896202 5562



Dimensional drawing

Pillar bearing

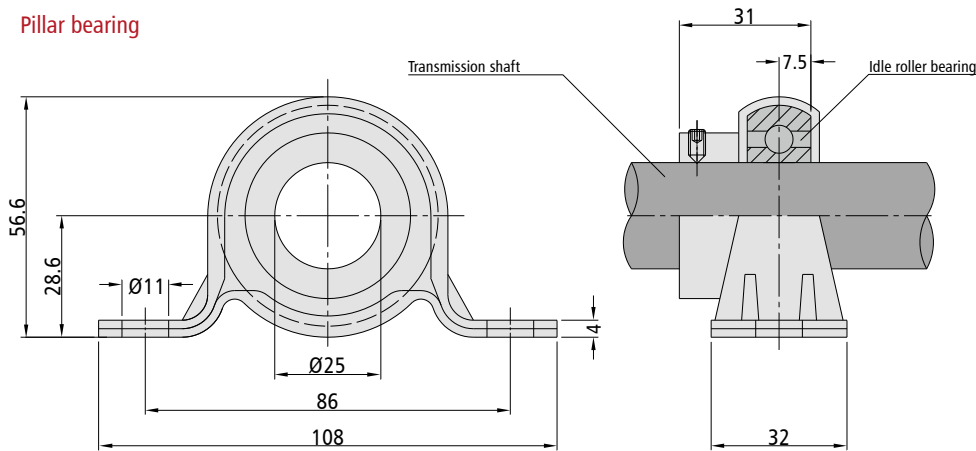

Technical data

Pillow block bearing is placed to avoid vibrations and to support the transmission shaft (recommended from a shaft length of 1500 mm)

Transferrable Torque	18 Nm
Body Weight of Coupling	0.3 kg
Weight of the shaft	0.540 kg/m
Moment of inertia of both couplings	2.68" ^{10⁻⁴} kg m ²
Moment of inertia of the shaft	8.171" 10-6 kg m ² /100 mm

Angle drives

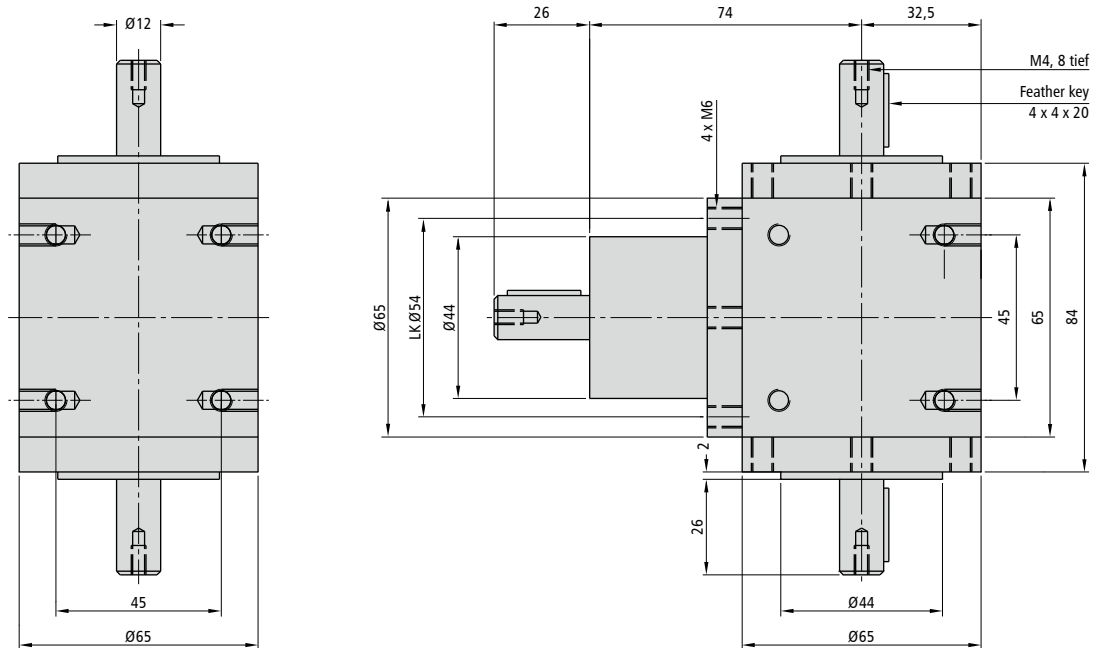

Coupling

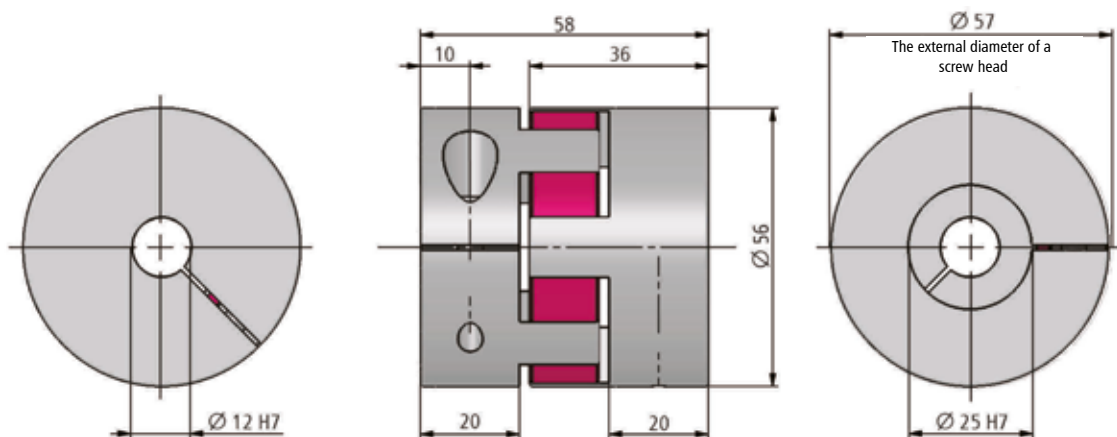



Engine modules

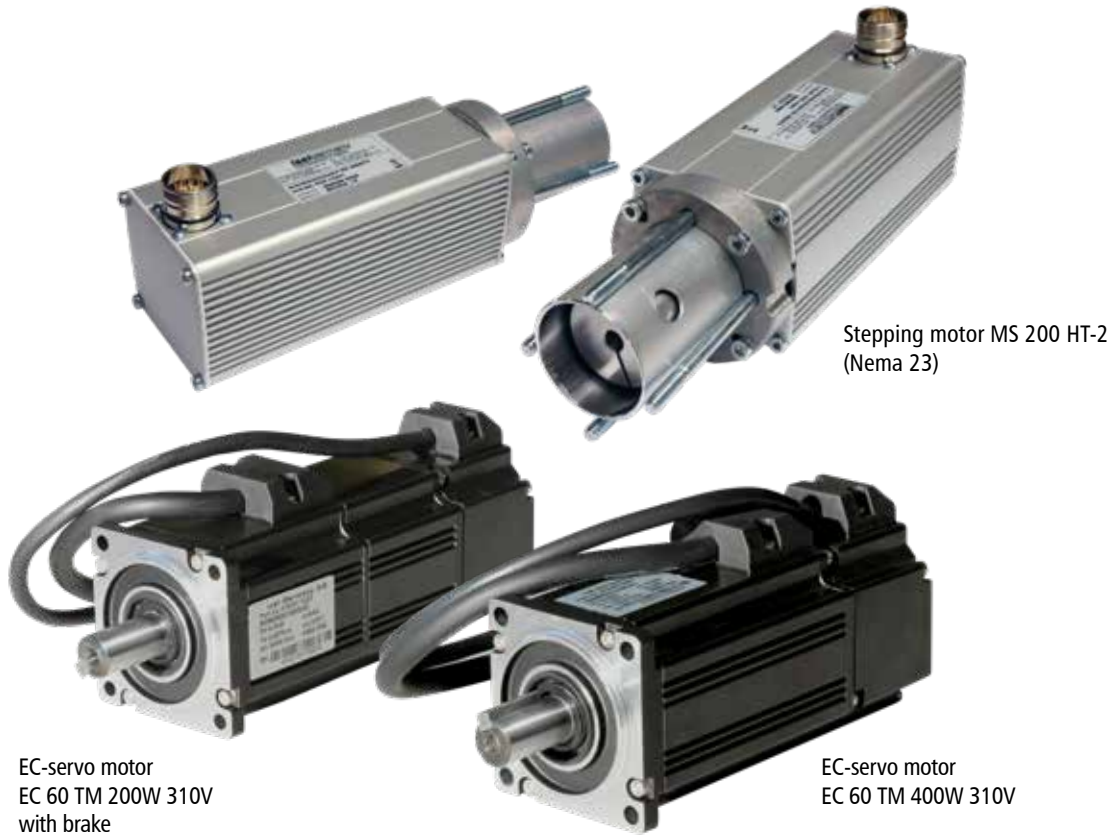

iLE 20/20

Direct drive	Part No.	Part No. equipped with brake	1-axis controller	Multi-axis controller	Motor cable Controller	Motor cable Control cabinet	Encoder line
EC-servo motor EC 60 TM (200W, 48V, 8-pole)	396421 006015	396421 026015	MC 1-20	iCU-EC / iPU-EC	392759 XX00	392760 XX00	392740 XX00
EC-servo motor EC 60 TM (200W, 310V, 8-pole)	396421 007015	396421 027015	MC 1-40	iCU-EC / iPU-EC	392759 XX00	392305 XX00	392740 XX00
EC-servo motor EC 60 TM (400W, 48V, 8-pole)	396440 008015	396440 028015	MC 1-20	iCU-EC / iPU-EC		392303 XX00	392740 XX00
EC-servo motor EC 60 TM (400W, 310V, 8-pole)	396440 007015	396440 027015	MC 1-40	iCU-EC / iPU-EC	392759 XX00	392305 XX00	392740 XX00
EC-servo motor EC 80 TM (750W, 310V, 8-pole)	396475 007015	396475 027015	MC 1-40	iCU-EC / iPU-EC	392759 XX00	392305 XX00	392740 XX00

Integrated drive	Part No.	Part No. equipped with brake	1-axis controller	Multi-axis controller	Motor cable Controller	Motor cable Control cabinet	Encoder line
EC-servo motor EC 60 TM (200W, 48V, 8-pole)	396421 1060	396421 1260	MC 1-20	iCU-EC / iPU-EC	392759 XX00	392760 XX00	392740 XX00
EC-servo motor EC 60 TM (200W, 310V, 8-pole)	396421 1070	396421 1270	MC 1-40	iCU-EC / iPU-EC	392307 XX00	392305 XX00	392740 XX00
EC-servo motor EC 60 TM (400W, 48V, 8-pole)	396440 1080	396440 1280	MC 1-20	iCU-EC / iPU-EC		392303 XX00	392740 XX00
EC-servo motor EC 60 TM (400W, 310V, 8-pole)	396440 1070	396440 1270	MC 1-40	iCU-EC / iPU-EC	392307 XX00	392305 XX00	392740 XX00



LES 4 / 5 / 6

Direct drive	Part No.	Part No. equipped with brake	1-axis controller	Multi-axis controller	Motor cable Controller	Motor cable Control cabinet	Encoder line
Stepping motor MS 135 (Nema 23)	396055 0060		IT 116 Flash	iMC-P / iMC-S8	392750 XX00		
Stepping motor MS 200 HT-2 (Nema 23)	396058 0060	396058 0260	IT 116 Flash	iMC-P / iMC-S8	392750 XX00		
EC-servo motor EC 60 TM (200W, 48V)	396421 0060	396421 0260	MC 1-20	iCU-EC / iPU-EC	392759 XX00	392760 XX00	392740 XX00
EC-servo motor EC 60 TM (200W, 310V)	396421 0070	396421 0270	MC 1-40	iCU-EC / iPU-EC	392759 XX00	392305 XX00	392740 XX00
EC-servo motor EC 60 TM (400W, 48V)	396440 0080	396440 0280	MC 1-20	iCU-EC / iPU-EC		392303 XX00	392740 XX00
EC-servo motor EC 60 TM (400W, 310V)	396440 0070	396440 0270	MC 1-40	iCU-EC / iPU-EC	392759 XX00	392305 XX00	392740 XX00
EC servo motor EC 80 TM (750W, 310V)	396475 0070	396475 0270	MC 1-40	iCU-EC / iPU-EC	392759 XX00	392305 XX00	392740 XX00
Stepping motor MS 300 HT-2 (Nema 34)	396082 0060	396082 0260	iMC-S8	iMC-S8	392750 XX00		
Stepping motor MS 600 HT (Nema 34)	396085 0060		iMC-S8	iMC-S8	392750 XX00		
Stepping motor MS 900 HT (Nema 34)	396088 0060		iMC-S8	iMC-S8	392750 XX00		

LES 5

Integrated drive	Part No.	Part No. equipped with brake	1-axis controller	Multi-axis controller	Motor cable Controller	Motor cable Control cabinet	Encoder line
Stepping motor MS 200 HT-2 (Nema 23)	396058 1060	396058 1260	IT 116 Flash	iMC-P / iMC-S8	392740 XX00		
EC-servo motor EC 60 TM (200W, 48V)	396421 1060	396421 1260	MC 1-20	iCU-EC / iPU-EC	392759 XX00	392760 XX00	392740 XX00
EC-servo motor EC 60 TM (200W, 310V)	396421 1070	396421 1270	MC 1-40	iCU-EC / iPU-EC	392307 XX00	392305 XX00	392740 XX00
EC-servo motor EC 60 TM (400W, 48V)	396440 1080	396440 1280	MC 1-20	iCU-EC / iPU-EC		392303 XX00	392740 XX00
EC-servo motor EC 60 TM (400W, 310V)	396440 1070	396440 1270	MC 1-40	iCU-EC / iPU-EC	392307 XX00	392305 XX00	392740 XX00

LES 4 / 6

Drive with lateral assembly	Part No.	Part No. equipped with brake	1-axis controller	Multi-axis controller	Motor cable Controller	Motor cable Control cabinet	Encoder line
Stepping motor MS 200 HT-2 (Nema 23)	396058 2060	396058 2260	IT 116 Flash	iMC-P			
EC-servo motor EC 60 TM (200W, 48V)	396421 2060	396421 2260	MC 1-20	iCU-EC / iPU-EC	392759 XX00	392760 XX00	392740 XX00
EC-servo motor EC 60 TM (200W, 310V)	396421 2070	396421 2270	MC 1-40	iCU-EC / iPU-EC	392307 XX00	392305 XX00	392740 XX00
EC-servo motor EC 60 TM (400W, 48V)	396440 2080	396440 2280	MC 1-20	iCU-EC / iPU-EC		392303 XX00	392740 XX00
EC-servo motor EC 60 TM (400W, 310V)	396440 2070	396440 2270	MC 1-40	iCU-EC / iPU-EC	392307 XX00	392305 XX00	392740 XX00

XX = cable length in meters



Motor pin assignments

Pin assignment for stepper motors

Motor connection

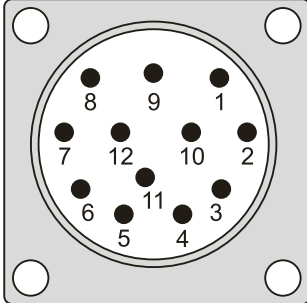

View of pin insert at the insertion side

M23 12-pin Pin	
1	Motor phase 1A
2	Motor phase 1B
3	Motor phase 2A
4	Motor phase 2B
5	+24V switch
6	+24V brake
7	GND switch
8	GND brake
9	Limit switch 1
10	Limit switch 2
11	---
12	---
Housing - cable shield	

Encoder connection

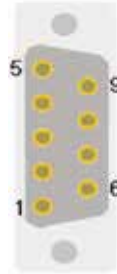

View of pin insert on the socket side

Sub-D 9-pin Pin	
1	Motor phase 1A
2	Motor phase 1B
3	Motor phase 2A
4	Motor phase 2B
5	+24V switch
6	+24V brake
7	Limit switch 2
8	GND brake
9	Limit switch 1
Housing - cable shield	

Pin assignment for brushless EC servo motors (BLDC) 48V

Motor connection

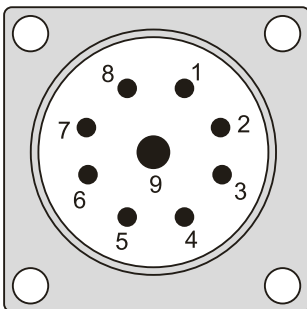

View of pin insert at the insertion side

M23 9-pol. (8+1) pin	
1	Motor phase U
2	Motor phase V
3	Motor phase W
4	---
5	+24V brake
6	GND brake
7	---
8	---
9	Earthing lead
Housing - cable shield	

Encoder connection

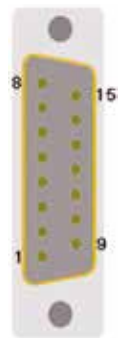

View of pin insert on the socket side

Sub-D 15-pin Pin	
1	Hall signal A
2	+5V encoder/Hall
3	Encoder track/Z
4	Encoder track/B
5	Encoder track/A
6	+24V switch
7	Limit switch 1
8	GND switch
9	Hall signal B
10	GND encoder
11	Encoder track Z
12	Encoder track B
13	Encoder track A
14	Hall signal C
15	Limit switch 2
Housing - cable shield	

Pin assignment for brushless EC servomotors (BLDC) 310V

Motor connection

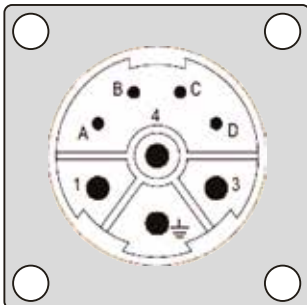

View of pin insert at the insertion side

M23 8-pol. (4+3+1) pin	
1	Motor phase U
PE	Earthing lead
3	Motor phase W
4	Motor phase V
A	+24V brake
B	GND brake
C	Temp +
D	Temp -
Housing - cable shield	

Encoder connection

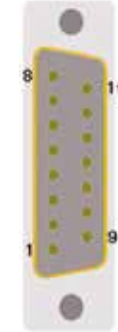

View of pin insert on the socket side

Sub-D 15-pin Pin	
1	Hall signal A
2	+5V encoder/Hall
3	Encoder track/Z
4	Encoder track/B
5	Encoder track/A
6	+24V switch
7	Limit switch 1
8	GND switch
9	Hall signal B
10	GND encoder
11	Encoder track Z
12	Encoder track B
13	Encoder track A
14	Hall signal C
15	Limit switch 2
Housing - cable shield	



Motor leads

Overview of motor leads for stepper, DC servo and EC motors*

Part number	Description
392750 0500	stepper motor lead M23 12-pin plug - socket 1:1, 5 m
392755 0500	stepper motor lead D-sub 9-pin plug - M23 12-pin socket, 5 m
392781 0500	stepper motor lead D-sub 9-pin plug - socket 1:1, 5 m
392759 0500	DC/EC servo motor lead M23 9-pin (8 + PE) plug - socket 1:1, 5 m
392760 0500	DC/EC servo motor lead M23 9-pin (8+PE) socket - wire end ferrules, 5 m
392740 0500	encoder lead D-sub 15-pin plug - socket 1:1, 5 m
392325 0500	encoder lead M23 17-pin socket - D-sub 15-pin plug, 5 m
392305 0500	EC/AC servo motor lead M23 310V (4+3+PE) socket - wire end ferrules, 5 m
392307 0500	EC servo motor lead M23 (4+3+PE) plug - socket 1:1, 5 m

All listed motor and encoder leads are fit for use with tow chains.

* Different lengths available on request!



Accessories LES

Energy guiding chain 3

- PU 1 piece at 1 m
- Part No.: 219204 1000

Connection elements designed for e-chain 3

- equipped with strain relief
- PU 1 set
- Part No.: 219205 0002



Dimensional drawing

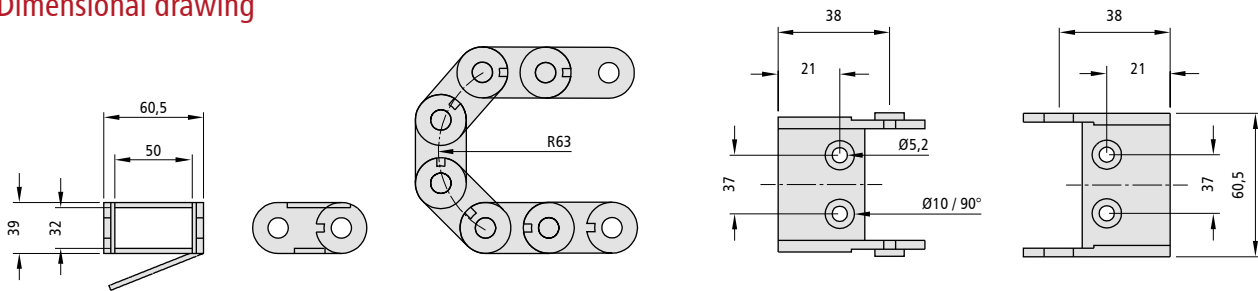

Gas spring attachment-kit

- Stroke 220 mm
- 490 nominal length
- Part No.: 216450 0001

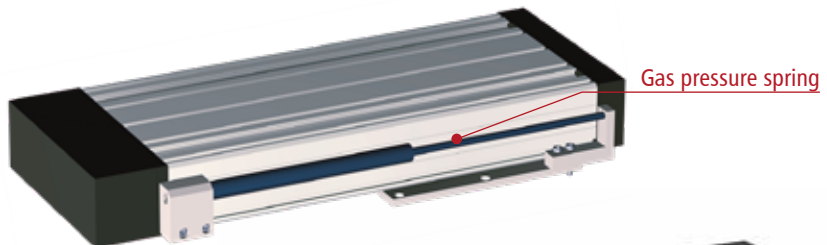

Gas spring attachment-kit

- Stroke 300 mm
- 690 nominal length
- Part No.: 216451 0001



Limit switch mounting kit LES 4

- made for external limit switches
- Part No.: 216460 0001

Assembly set is created for sealing air

- made for LES4 - LES6
- Part No.: 216460 0006

Limit switch mounting kit LES 5

- made for external limit switches
- Part No.: 216460 0002

Mounting plate designed for screwing from above

- made for LES4 Part No.: 623025 6837
- made for LES5 Part No.: 623025 6833
- made for LES6 Part No.: 675015 0362

Limit switch mounting-kit LES 6

- made for external limit switches
- Part No.: 216460 0003



Connection angle WV

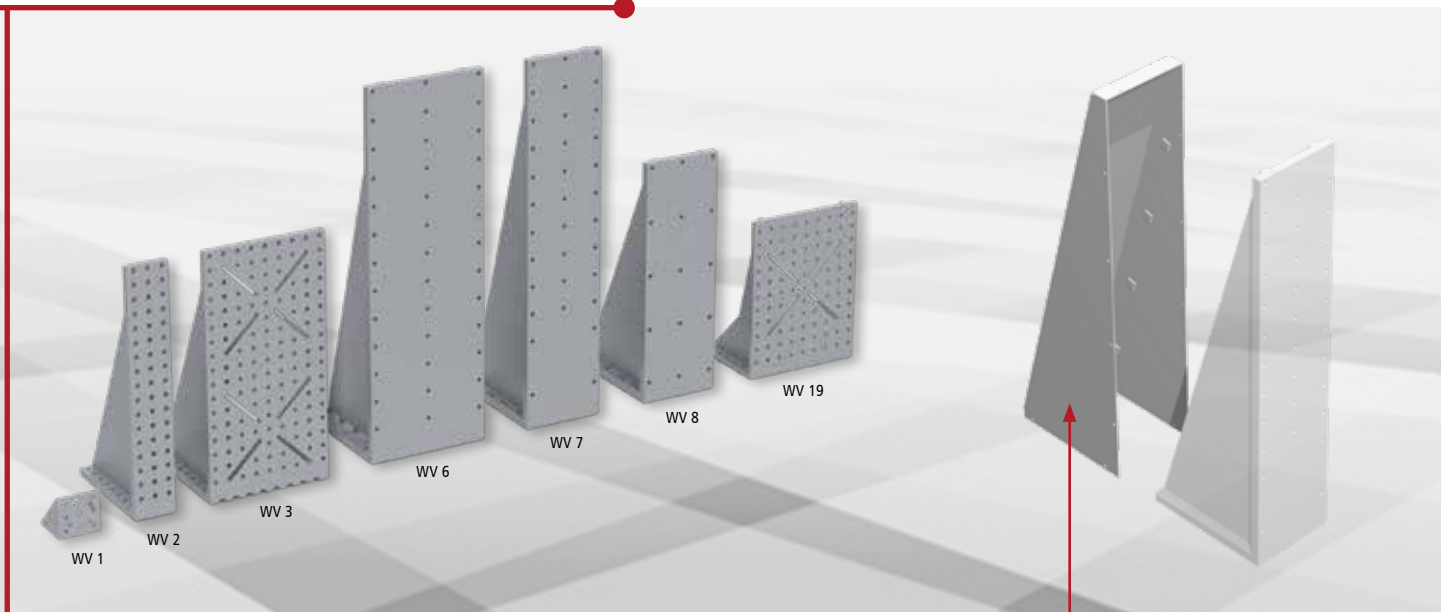

WV 1

- blank
 - Aluminum cast (0.2 kg)
 - L71 x W75 x H71
- Part No.: [209110 0010](#)

WV 2

- blank
 - Aluminum cast (2.6 kg)
 - L221 x W75 x H446
- Part No.: [209110 0022](#)

WV 3

- blank
 - Cast aluminum (5.8 kg)
 - L221 x W221 x H446
- Part No.: [209110 0032](#)

WV 6

- blank
 - Aluminum, welded (13.3 kg)
 - L220 x W220 x H670
- Part No.: [209110 0060](#)

WV 7

- blank
 - Aluminum, welded (10.8 kg)
 - L220 x W145 x H670
- Part No.: [209110 0070](#)

WV 8

- blank
 - Aluminum, welded (7.4 kg)
 - L222 x W145 x H446
- Part No.: [209110 0080](#)

WV 19

- blank
 - Aluminum, cast aluminum (2.5 kg)
 - L150 x W221 x H300
- Part No.: [209110 0190](#)

Cover plate designed for WV 2

- naturally anodized
 - Aluminum sheet (0.8 kg)
- Part No.: [209110 0021](#)

Cover plate designed for WV 3

- naturally anodized
 - Aluminum sheet (1.15 kg)
- Part No.: [209110 0031](#)

Cover plate designed for WV 6

- naturally anodized
 - Aluminum sheet (1.8 kg)
- Part No.: [209110 0061](#)

Cover plate designed for WV 7

- naturally anodized
 - Aluminum sheet (1.5 kg)
- Part No.: [209110 0071](#)

Cover plate designed for WV 8

- naturally anodized
 - Aluminum sheet (1 kg)
- Part No.: [209110 0081](#)

Cover plate designed for WV 19

- naturally anodized
 - Aluminum sheet (0.8 kg)
- Part No.: [209110 0191](#)



Connection angle WV

WV 1: L 71 x W 75 x H 71 mm

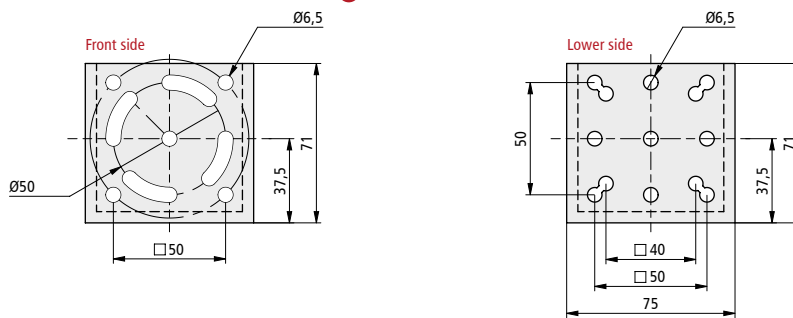

WV 2: L 221 x W 75 x H 446 mm

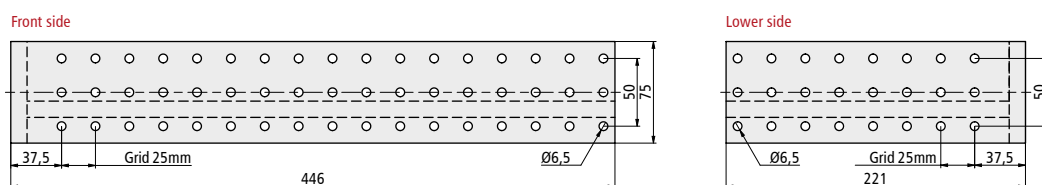

WV 3: L 221 x W 221 x H 446 mm

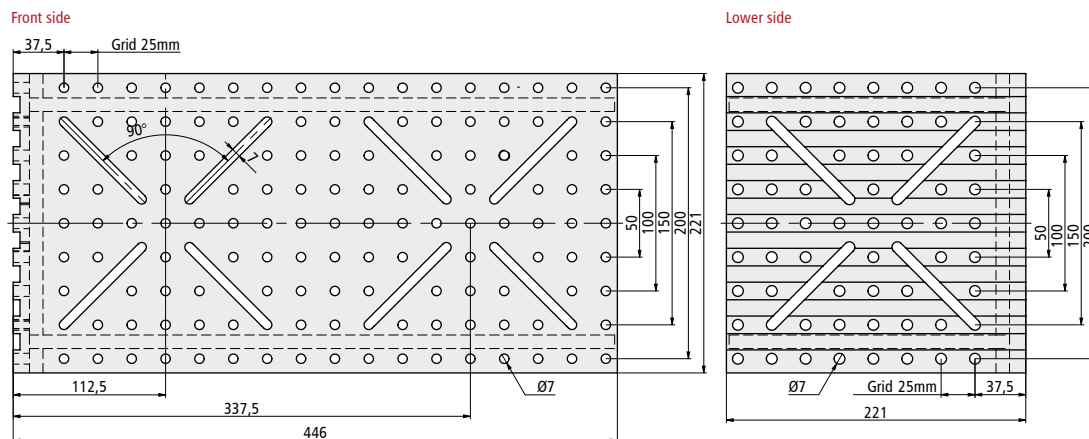

WV 6: L 220 x W 220 x H 670 mm

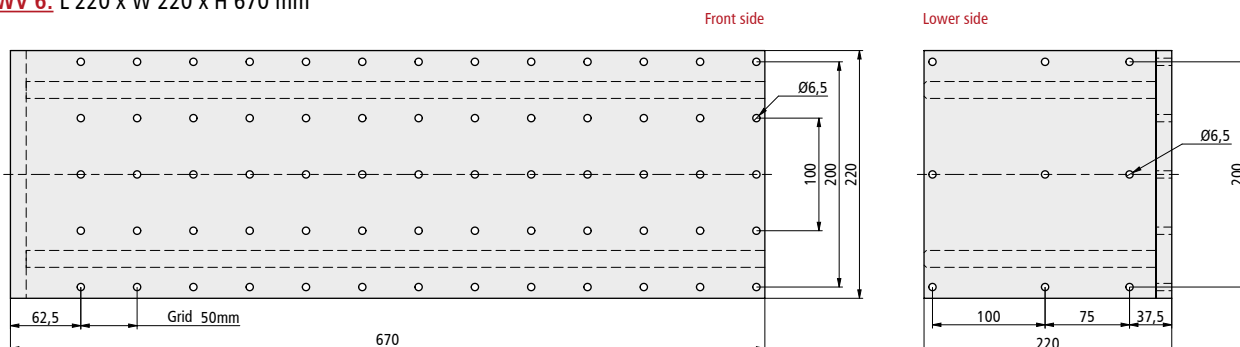



Connection angle WV

WV 7: L 220 x W 145 x H 670 mm

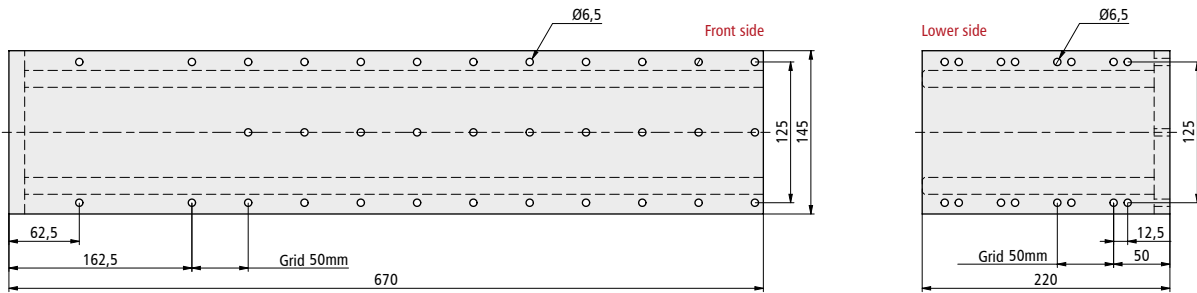

WV 8: L 222 x W 145 x H 446 mm

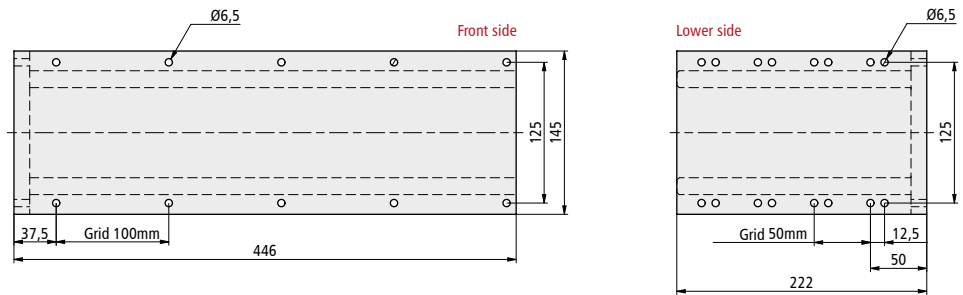

WV 19: L 150 x W 221 x H 300 mm

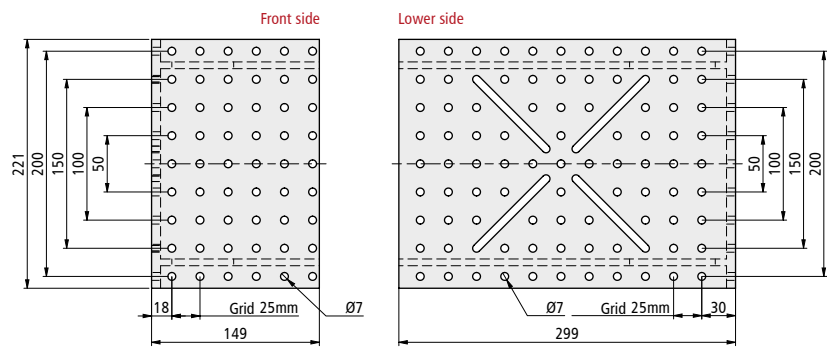



Slide plates PS

PS 1: L 125 x W 70 x H 7.7 mm

Assembly on:

: LES 4 with 1 x WS 5/70

Part No.: **277001**

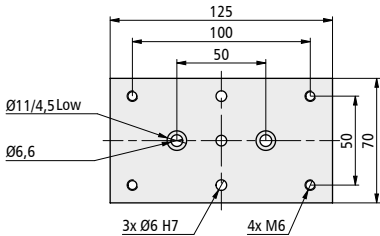

PS 2: L 255 x W 70 x H 7.7 mm

Assembly on:

LES 4 with 2 x WS 5/70

Fastening option for: connecting bracket WV 2 / WV 5

Part No.: **277002**

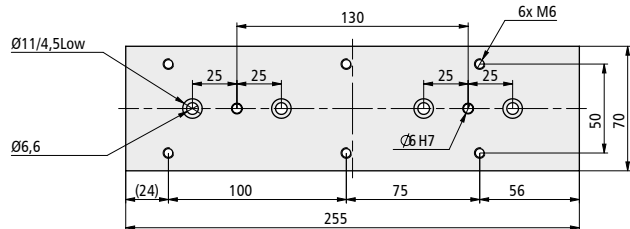

PS 3: L 220 x W 125 x H 7.5 mm

Assembly on:

LES 5 with 2 x WS 5/70

Part No.: **277003**

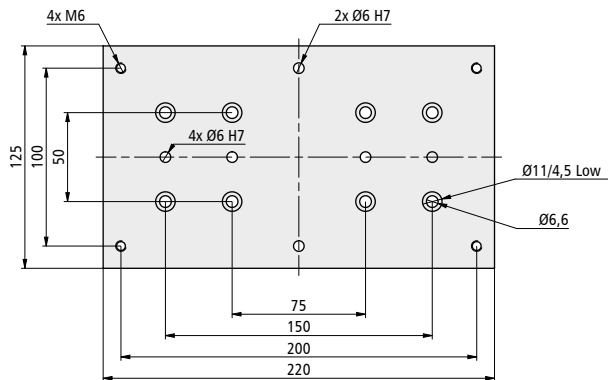

PS 4: L 255 x W 220 x H 7.5 mm

Assembly on: LES 5 with 4 x WS 5/70

Assembly cross table: LES 5 equipped with LES 5 (in connection with VP 2), and fastening option for: connection bracket WV 3 / WV 6

Part No.: **277004**

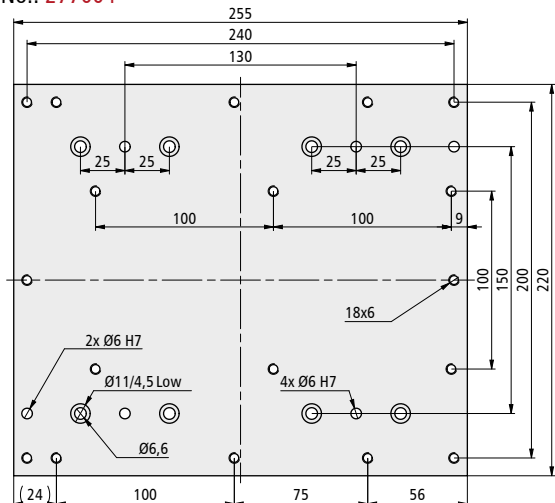

PS 6: L 220 x W 125 x H 7.5 mm

Assembly on: LES 4 with 2 x WS 5/70

Assembly cross table: LES 4 equipped with LES 5 (in connection with PS3), and fastening option for: LES 4 / LES 5

Part No.: **277011**

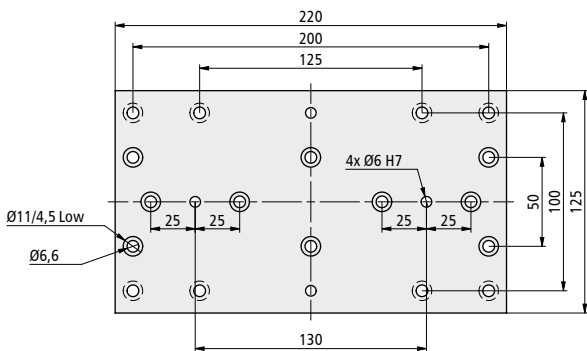

PS 7: L 255 x W 220 x H 7.5 mm

Assembly on: LES 6 equipped with 4 x WS 5/70

Assembly cross table: LES 6 with LES 5 (in connection with PS 4)

Part No.: **277016**

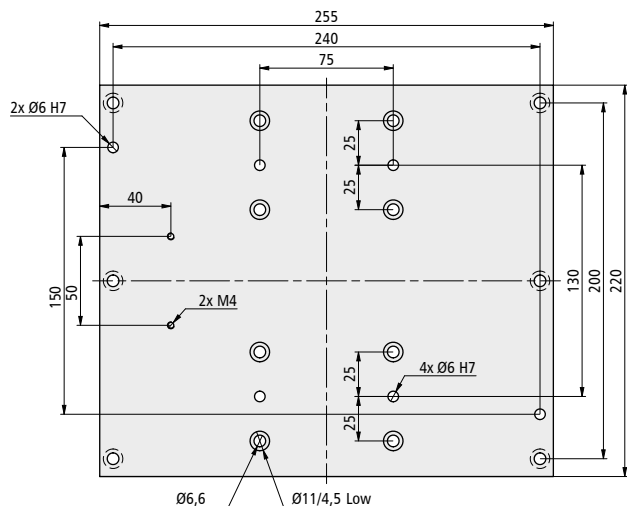



Slide plates PS

PS 8: L 125 x W 145 x H 7.5 mm

Assembly on:
LES 6 with 2 x WS 5/70

Part No.: 277017

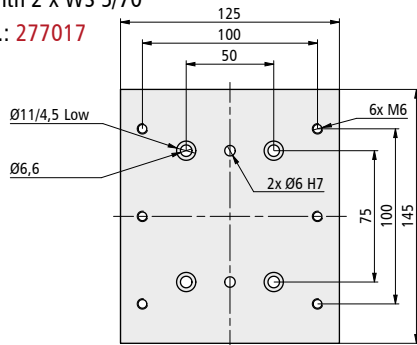

PS 9: L 250 x W 145 x H 7.5 mm

Assembly on: LES 6 with 4 x WS 5/70,
fastening option made for: Connection bracket WV 7

Part No.: 277018

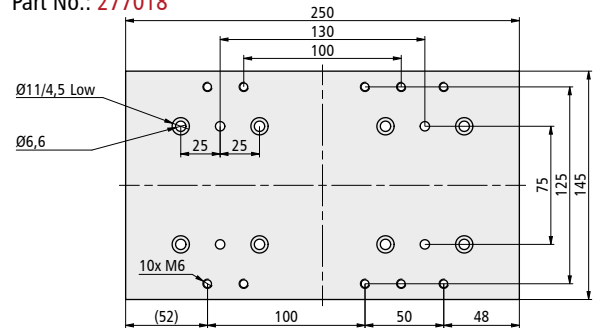

PS 10: L 210 x W 215 x H 7.5 mm

Assembly on: LES 6 with 4 x WS 5/70,
assembly cross table: LES 6 equipped with LES 6
(in connection with PS 11)

Part No.: 277019

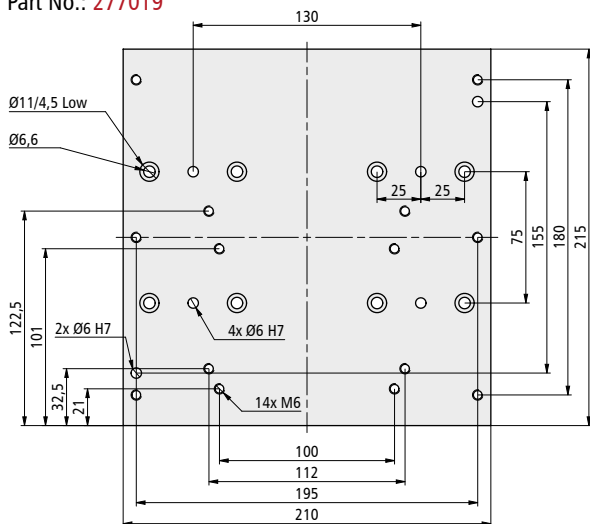

PS 11: L 210 x W 215 x H 7.5 mm

Assembly on: LES 6 with 4 x WS 5/70
assembly cross table: LES 6 equipped with LES 4
(in connection with PS10) fastening option for: LES 6

Part No.: 277020

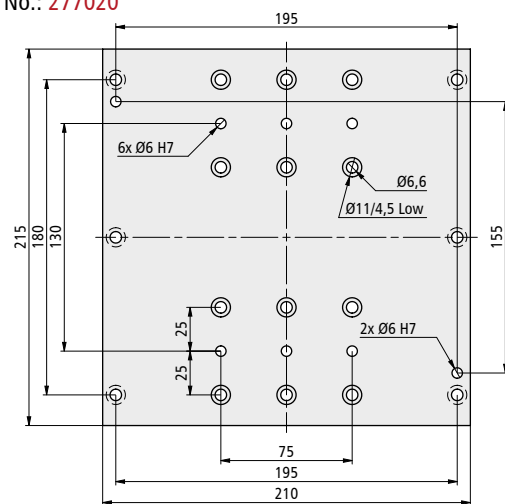

PS 12: L 220 x W 180 x H 7.5 mm

Assembly on: LES 6 with 4 x WS 5/70
fastening option for: LES 5

Part No.: 277021

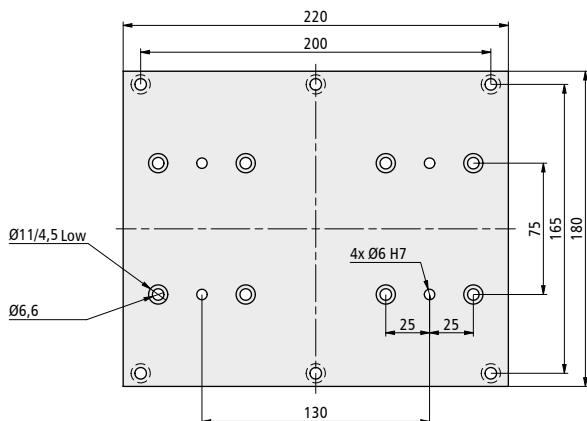

Connection plate VP 2: L 255 x W 220 x H 7.5 mm

Assembly on: LES 5 with 4 x WS 5/70
fastening option for: LES 5

Part No.: 277006

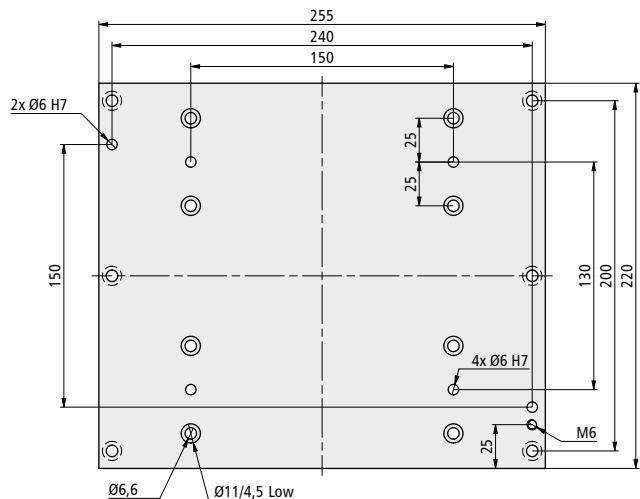



Precisely with high dynamics throughout long distances

The linear units equipped with toothed belt drives are the first choice when it comes to high speeds and long travel distances, thanks to the precise positioning and high repeat accuracy in the areas of handling, assembly automation and machine handling. The compact and flexible modules turn on greatly dynamic movements, and that is why short cycle times do not require big investments.

The linear units are, therefore, the best for both fast handling-positioning tasks, and for performing light to medium-heavy loads. The modules are designed of extruded aluminum casing profiles, linear rail guides are based on the recirculating ball principle equipped with shaft slides or roller guides. Different versions of the linear units, which are equipped with toothed belt drive, provide our customers a large variety of products. Since there are countless varieties of accessories and due to the modular design, we can also adapt linear units to your individual demands or combine them together into multi-axis systems.

Functional overview – linear unit equipped with toothed belt drive

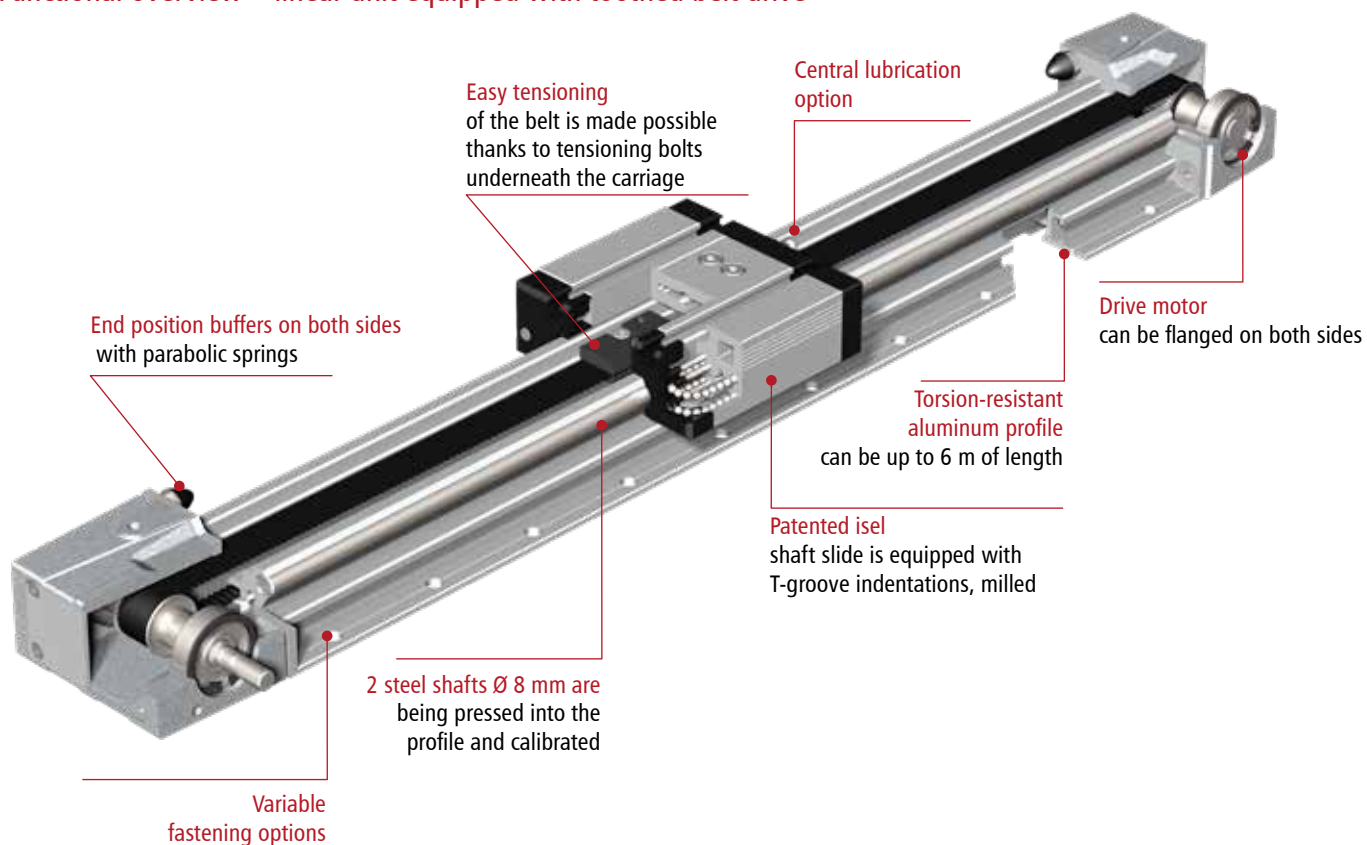



Combination examples

LEZ 1

- 2-axis flatbed arrangement

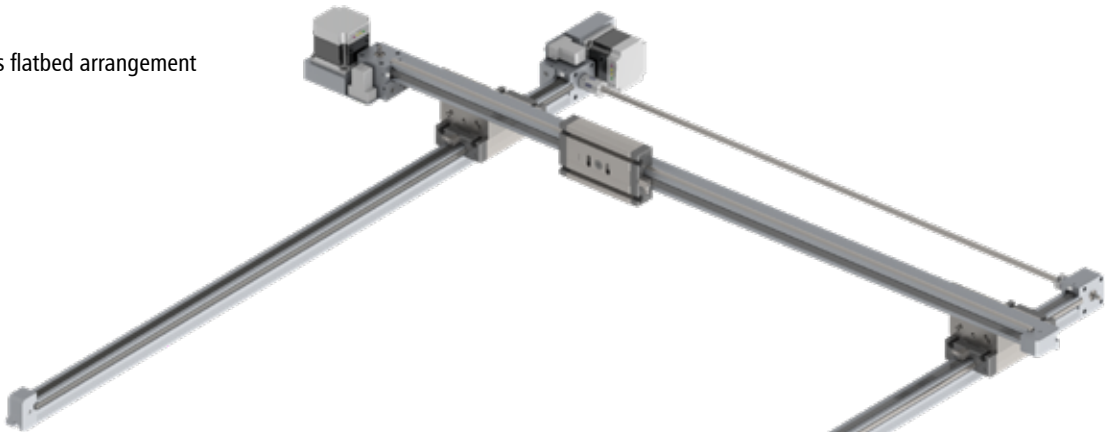

XY stage LEZ 1

- 2 x LEZ 1
- 1 x connection plate



2-axis H-construction

- 2 x LEZ 3
- 1 x LEZ2
- Transmission shaft

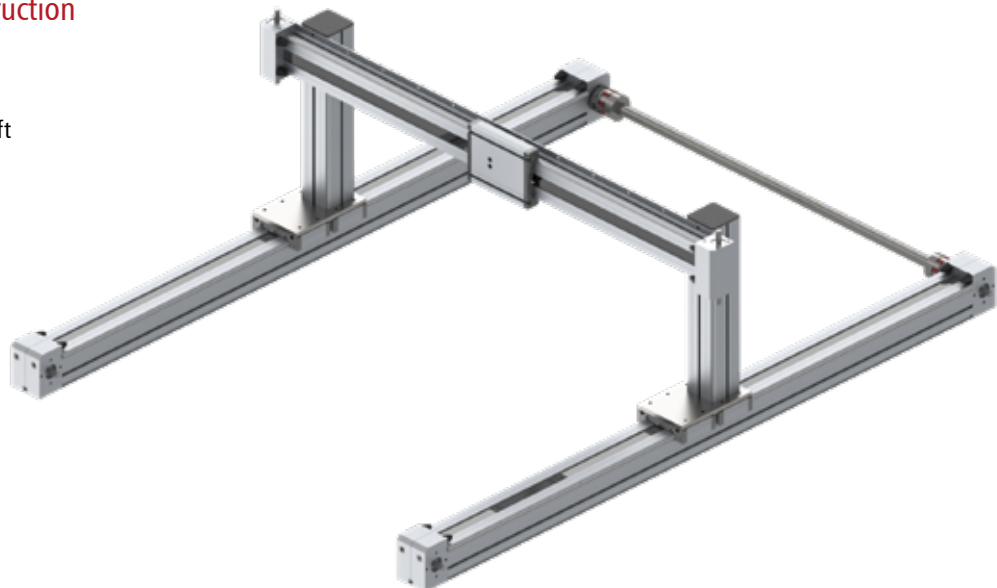



Linear unit equipped with toothed belt drive LEZ 4G

- Stainless steel cover as standard
- External limit switch sensors as standard
- Feed speed up to 5 m/sec
- Repeat accuracy +/- 0.2 mm
- Standard length up to 3 m
- Feed per revolution 90 mm
- Planetary gearbox 1:3
- Direct motor adaptation via hollow shaft
- Motor connection for flange 60 mm

Options:

- Special lengths and other reduction ratios on request

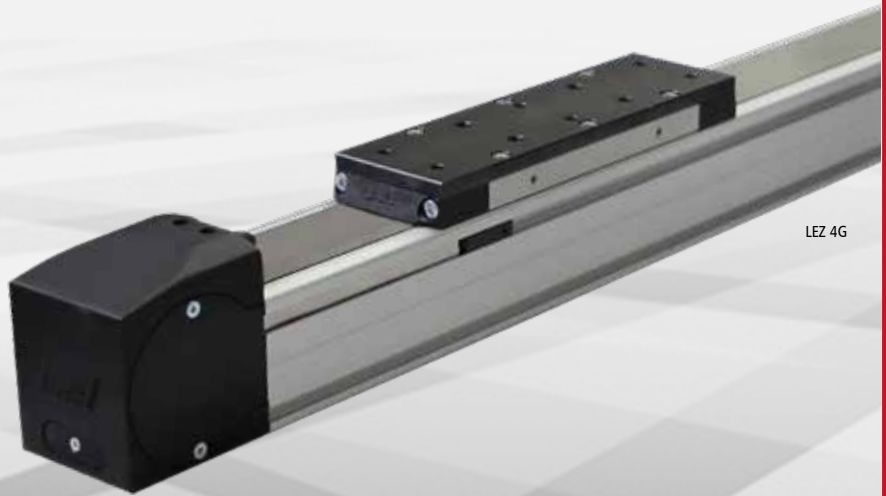

Order key

232200 XXXX

Drive block version

- 0** = without motor / without limit switch
- 1** = for motor right / with limit switch
- 2** = for motor left / with limit switch

Profile lengths (mm)*

- z.B. **030** = 300 mm (min.)
- 300** = 3000 mm (max.)

*Standard profile lengths can be ordered in 100 mm increments (travel = profile length -210 mm)

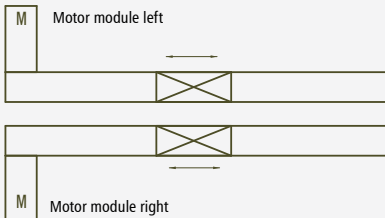

Limit switch, movable

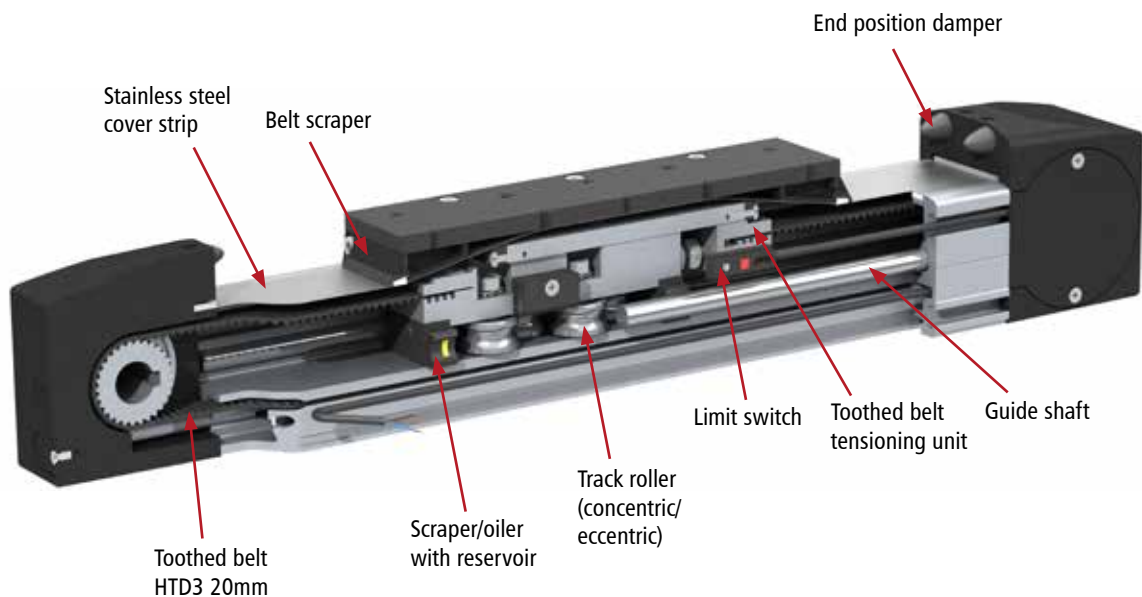

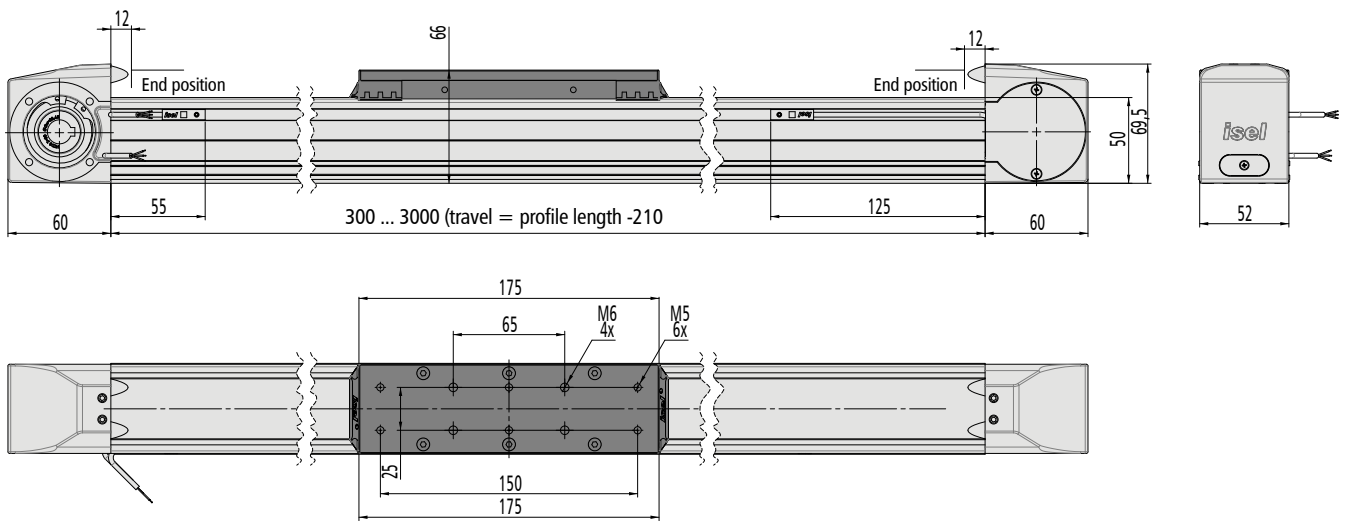

Technical data

Belt typ	HTD 3M, width 20 mm
Weight without drive module	1000 mm = 7,75 kg
Specific mass of the toothed belt	0,05 kg/m
Carriage weight	0,85 kg
Specific guide weight	0,280 kg/100 mm
Feed per revolution	90 mm
Mass moment of inertia of the synchronizing pulleys	0,00011 kgm ²

Load data

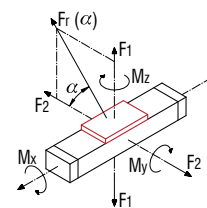

$$Fr(\alpha) = \frac{F_2}{\cos \alpha}$$

$$Fr(\alpha) = \frac{F_1}{\sin \alpha}$$

Load diagram

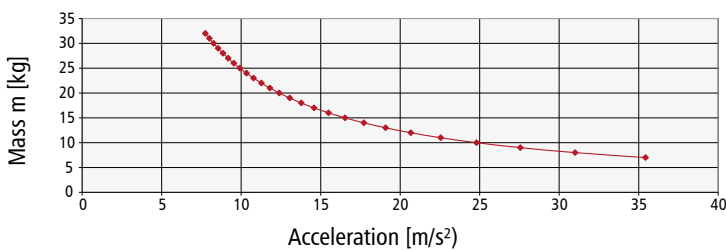

C _y	2800 N
C _{0y}	1488 N
C _z	1776 N
C _{0z}	1032 N
F ₁ static	200 N
F ₁ dynamic	850 N
F ₂ static	300 N
F ₂ dynamic	1400 N

Deflection

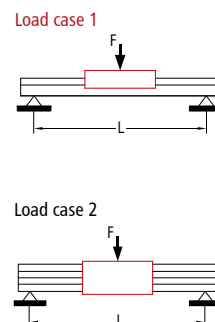
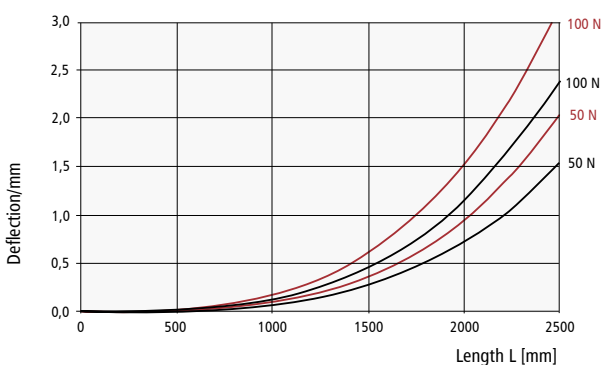

M _{0x} static	23 Nm
M _{0y} static	35 Nm
M _{0z} static	37 Nm
M _x dynamic	40 Nm
M _y dynamic	60 Nm
M _{z1} dynamic	70 Nm



Drive modules | LEZ 4G

Drive module with stepper motor and EC servo motor

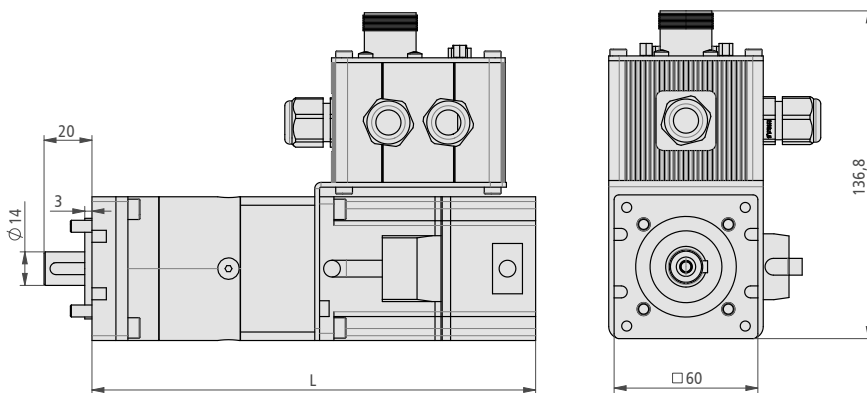

Part no.	Servo motor without gearbox	L
396421 9060X	200W / 48V without brake	102
396421 9260X	200W / 48V with brake	131
396421 9070X	200W / 310V without brake	102
396421 9270X	200W / 310V with brake	131

Part no.	Servomotor with gearbox 3:1	L
396421 9062X	200W / 48V without brake	185
396421 9262X	200W / 48V with brake	214
396421 9072X	200W / 310V without brake	185
396421 9272X	200W / 310V with brake	214

Part no.	Stepper motor without gearbox	L
396058 9060	MS200HT without brake	88
396058 9260	MS200HT with brake	126

Part no.	Stepper motor with gearbox 3:1	L
396058 9061	MS200HT without brake	164
396058 9261	MS200HT with brake	202

Connection flange for alternative motors



Accessories | LEZ 4G

Mounting set Connection bracket for LEZ 4G

Part no. 290022 0002



Square nut M5, DIN 562 8x8mm, galvanized steel Part no. 892164 0000

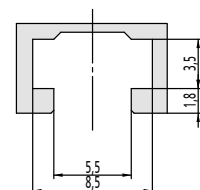



Transmission shaft

- prepared in lengths of 1 m and 2 m
-> d= 12mm
- Mechanical connection via two hollow shaft couplings included in the scope of delivery
- Center distance < 1m
Part no. 219002 1000
- Center distance > 1m
Part no. 219002 2000
(including pedestal bearing)

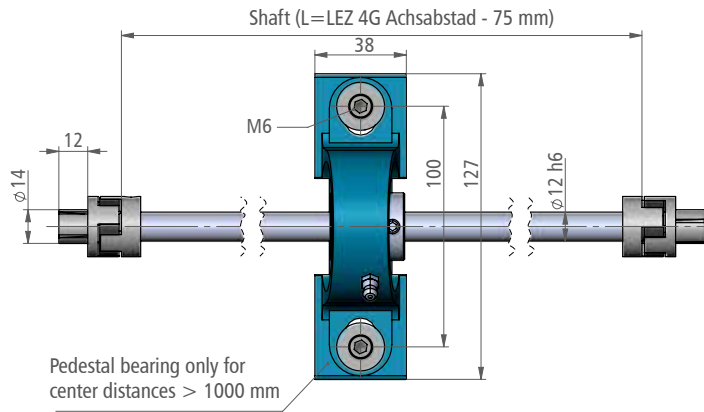

Clamping claws

- for attaching the axle to the mounting plate and for axle combinations
 - threaded holes suitably prepared for mounting an H-construction
 - PU = 10 pieces, incl. screws and sliding nuts
- Part no. 290022 0001

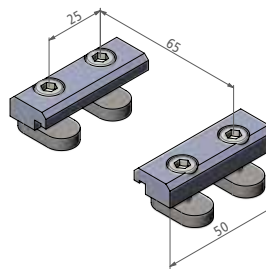

Order example | LEZ 4G

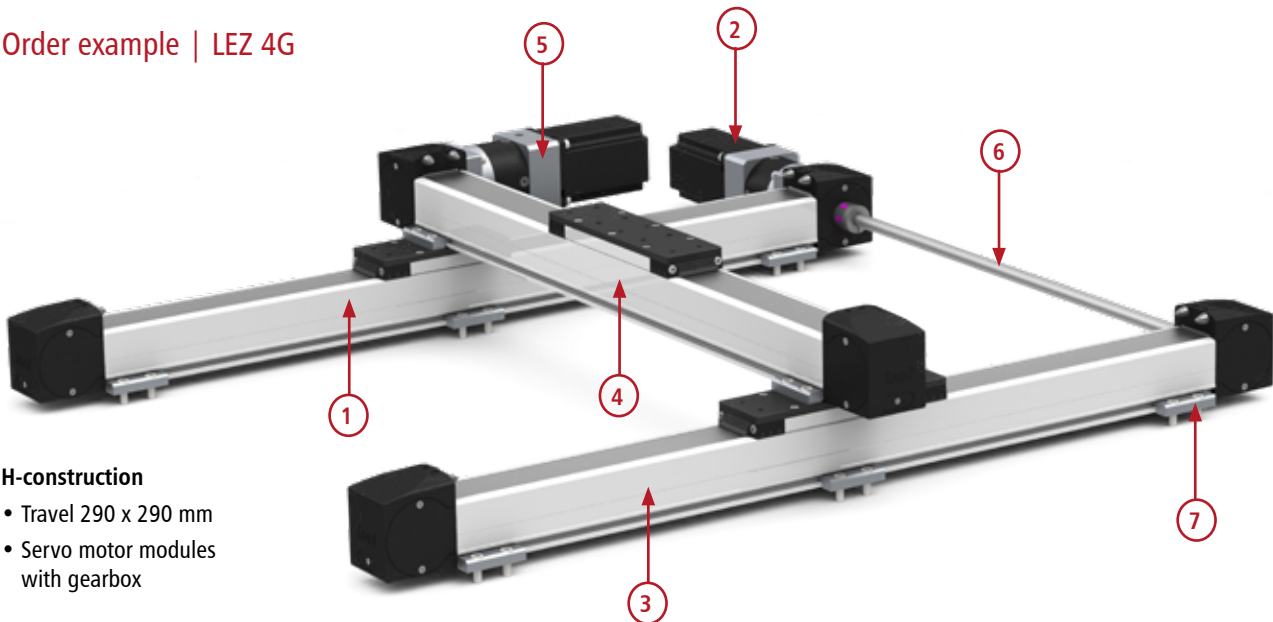

H-construction

- Travel 290 x 290 mm
- Servo motor modules with gearbox

1. LEZ 4G for motor right, with limit switch
Part no. 232200 1500

3. LEZ 4G without motor, without limit switch
Part no. 232200 0500

5. Servo motor module with gearbox
Part no. 396421 9062X

7. Clamping claws for LEZ 4G, PU 10 pieces
Part no. 290022 0001

2. Servo motor module with gearbox
Part no. 396421 9062X

4. LEZ 4G for motor left
Part no. 232200 2500

6. Transmission shaft < 1 m, incl. couplings
Part no. 219002 1000

Ask for your individual offer.



Linear unit equipped with toothed belt drive LEZ 1

- Aluminum profile, Miniature linear guide LFS-8-2
- Clearance-free feed is equipped with toothed belt drive toothed belt with 3 mm gradient and width of 9 mm
- Feed per rotation: 60 mm
- Repeatability less than or equal to ± 0.2 mm
- Maximum feed of 1.5 m/s
- Overrun limit switch is equipped with connection cable
- Mechanical limit switches

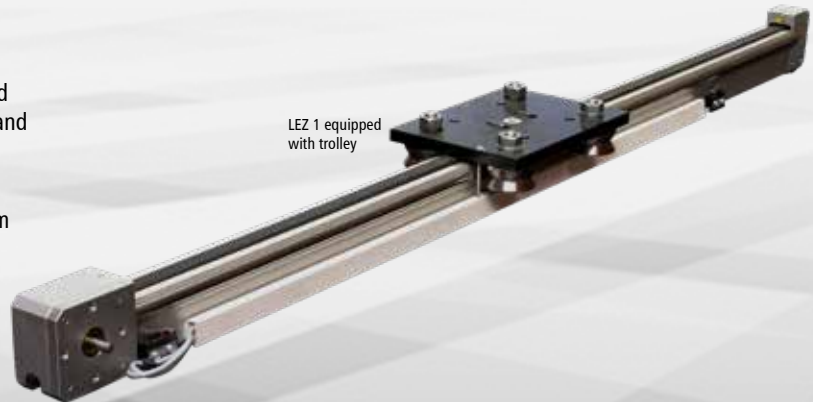

LEZ 1 equipped with trolley

Options:

- Special lengths in grid size of 100 mm upon request, maximum size - 6,000 mm
- Fastening done via integrated threaded rail M6, grid size of 50 mm
- Stepping motor drive module of 50Ncm, SubD Part No.: 396049 3010L
- Reed sensor

Load pattern

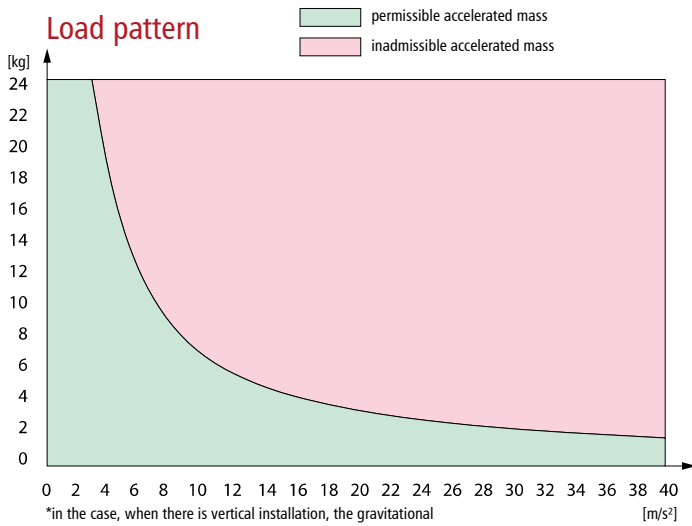

*in the case, when there is vertical installation, the gravitational acceleration ($g = 9.81$ m/s²) must be taken into account

Technical data

Belt type	HTD 3 M, width 9mm
Slide weight	0.430 kg
Weight without drive module	1000 mm = 3 kg
specific mass of the toothed belt	0.0225 kg/m
Carriage weight	1.03 kg
specific guidance on weight	0.200 kg/100 mm
Feed per rotation	60 mm
Effective diameter of the synchronizing pulleys	$\varnothing 19.10$ mm
Mass moment of inertia of the synchronizing pulleys	5.585×10^{-7} kg m²

Order key

232005 XXXX

Drive/slide carriage
8 = without motor, with shaft slide
9 = without motor, with carriage

Profile lengths LFS-8-2 (mm)
 298, 398, 498, 598, 675, 698, 798, 998, 1,498, 1,798, 1,998, 2,498, 2,998
 (for example 398 mm = 040, 675 mm = 068)
 Option: up to 6,000 mm

Drive module with stepping motor MS-045 HT



Drive module equipped with stepping motor MS-045 HT (reduction 2:1)



Dimensional drawings

without motor, equipped with shaft slide

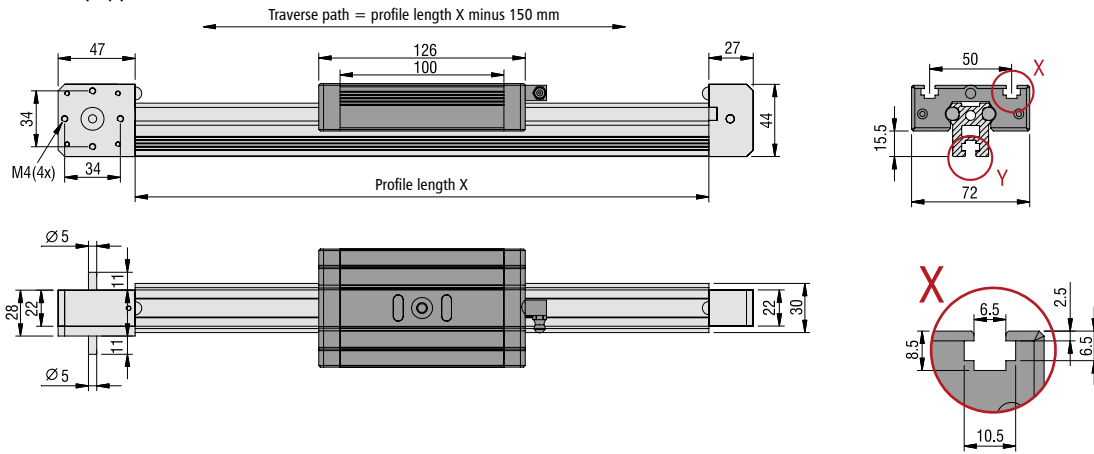

without motor, equipped with trolley

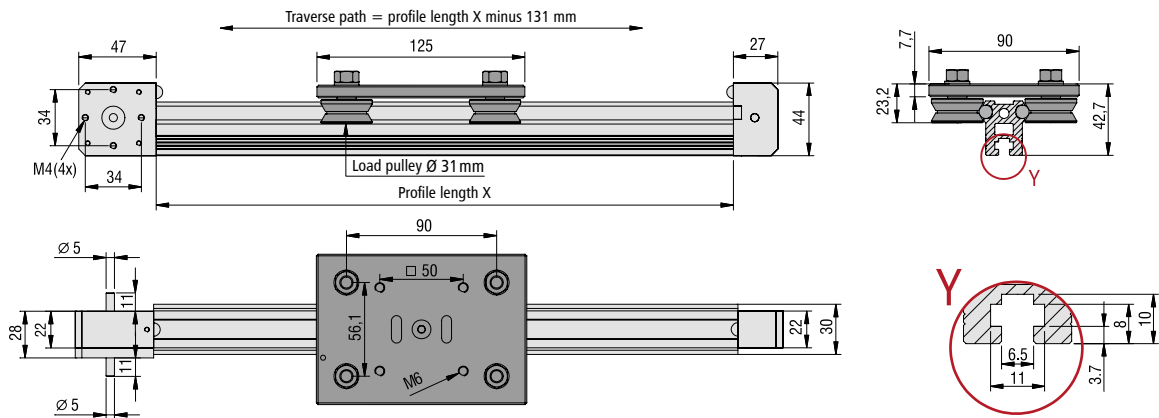

Drive modules

Drive module is with stepper motor MS-048 HT (direct drive)
feed: 60 mm / revolution
Part No.: 396048 3015

Drive module is with stepper motor MS-048 HT (reduction 2:1)
Feed: 30 mm / rotation
Part No.: 396049 3015

Drive module is with stepper motor MS-135 HT (reduction 2:1)
Feed: 30 mm / rotation
Part No.: 396056 3015

Drive module equipped with servo motor EC-42 (Reduction 2:1)
Feed: 30 mm / rotation
Part No.: 396407 3060

Total length including the motor module:
Profile length + 163.5 mm

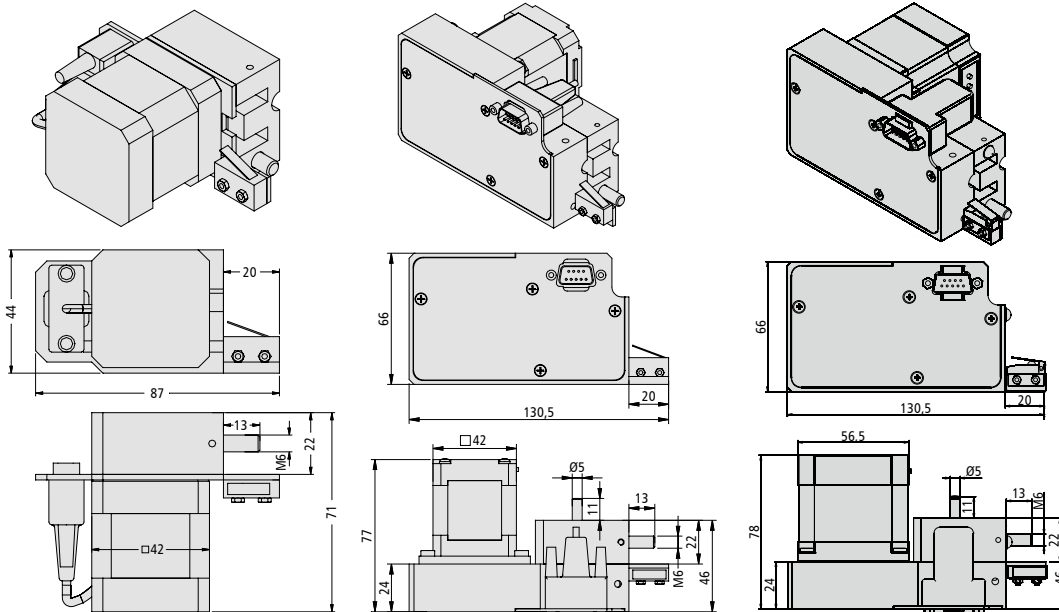



Linear unit equipped with toothed belt drive LEZ 2

- Aluminum profile, with miniature linear guide LFS-8-5
- Clearance-free feed is equipped with toothed belt drive toothed belt with 5 mm gradient and width of 25 mm
- Maximum feed of 5 m/s
- Shaft slide WS 3, L 176 x W 130 mm
- Feed per rotation: 70 mm
- Repeatability less than or equal to ± 0.2 mm
- available in lengths up to 6,000 mm
- Overrun limit switch is equipped with connection cable
- Mechanical limit switches



Options:

- Special lengths in grid size of 100 mm upon request, maximum size - 6,000 mm
- Also as a direct drive, which is equipped with a stepping motor servo motor
- inductive limit switches

Load pattern

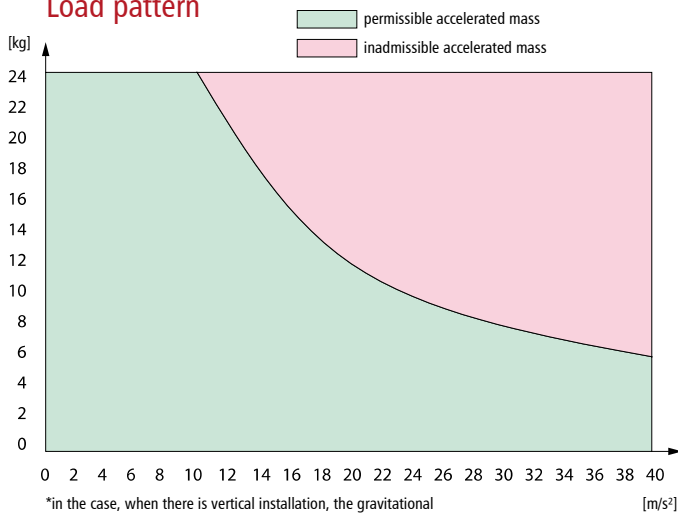

Technical data

Belt type	HTD 5M, width 25 mm
Slide weight	0.940 kg
Weight without drive module	1000 mm \cong 7.9 kg
specific mass of the toothed belt	0.09 kg/m
Carriage weight	2.03 kg
specific guidance on weight	0.472 kg/100 mm
Feed per rotation	70 mm
Effective diameter of the synchronizing pulleys	$\varnothing 22.28 \text{ mm}$
Mass moment of inertia of the synchronizing pulleys	$5.58 \cdot 10^{-6} \text{ kgm}^2$

Order key

232002 XXXX

Drive/slide carriage
8 = without motor, with shaft slide
9 = without motor, with carriage

Profile lengths (mm)
 696, 996, 1496, 1996, 2496, 2996
 (e.g. 696 mm = 070
 1496 mm = 150)
 Option: up to 6000 mm

Drive module is equipped with servo motor EC 60





Dimensional drawings

without motor, equipped with shaft slide

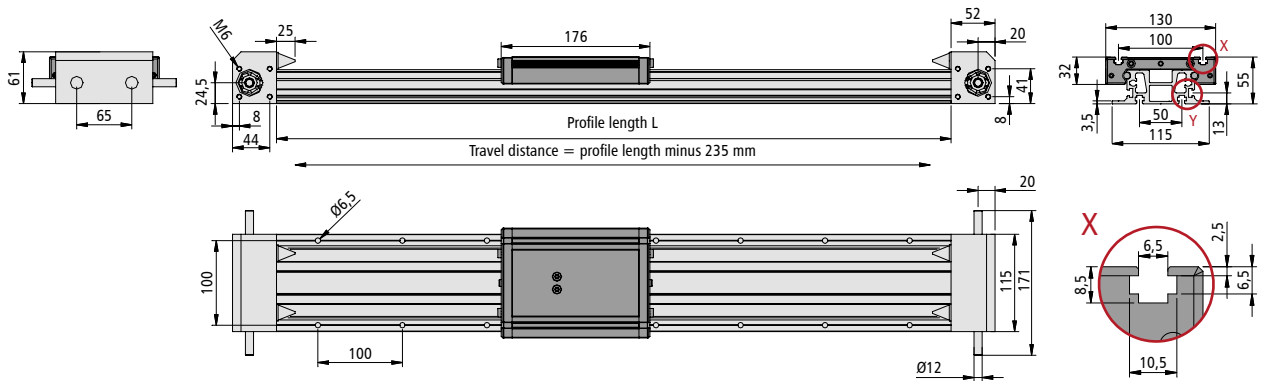

without motor, equipped with trolley

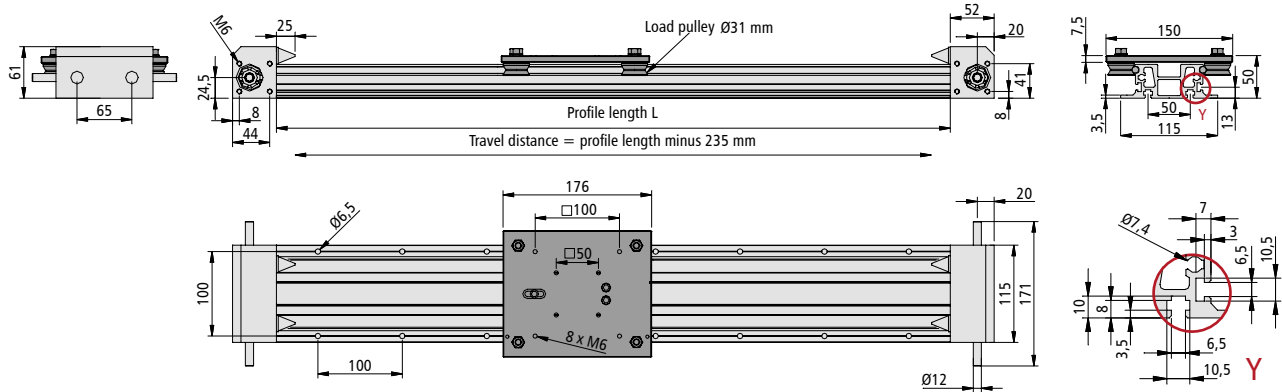

Drive modules

The drive module is equipped with both stepper motor and EC servo motor
reduction 2:1 - feed: 35mm / revolution

Part No.	Motor module	Length, L
396086 3060	Stepping motor MS 600 HT	146.5 mm
396089 3060	Stepping motor MS 900 HT	174.5 mm
396421 3060	EC servo motor EC60 TM 200W 48V	151.5 mm
396421 3070	EC servo motor EC60 TM 200W 310V	155.7 mm
396440 3080	EC servo motor EC60 TM 400W 48V	179.5 mm
396440 3070	EC servo motor EC60 TM 400W 310V	183.7 mm
396421 3260	EC servo motor EC60 TM 200W 48V - with brake	198.5 mm
396421 3270	EC servo motor EC60 TM 200W 310V - with brake	202.7 mm
396440 3280	EC servo motor EC60 TM 400W 48V - with brake	226.5 mm
396440 3270	EC servo motor EC60 TM 400W 310V - with brake	226.5 mm

Dimensional drawing Stepping motor

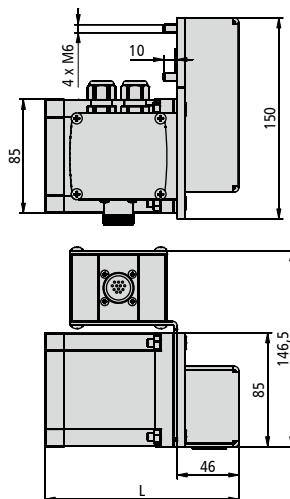

Dimensional drawing EC servo motor

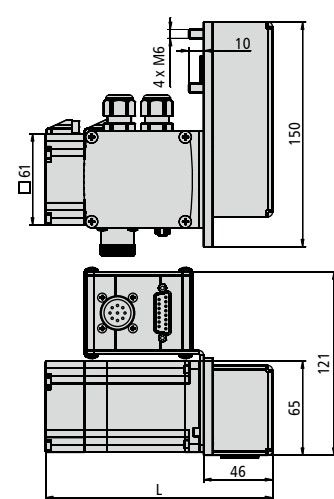



Linear unit equipped with toothed belt drive LEZ 3

- Aluminum profile, miniature linear guide LFS-8-4
- Clearance-free feed is equipped with toothed belt drive toothed belt with 5 mm gradient and width of 25 mm
- Maximum feed of 5 m/s
- Shaft slide WS 3, L 176 x W 130 mm
- Feed per rotation: 70 mm or 150 mm
- Repeatability less than or equal to ± 0.2 mm
- Limit and/or reference switch accuracy < 0.1 mm
- available in lengths up to 6,000 mm
- Motor modules can be flanged on the right and left side
- Mechanical limit switches



Options:

- Special lengths in grid size of 100 mm upon request, maximum size - 6000 mm

Load pattern

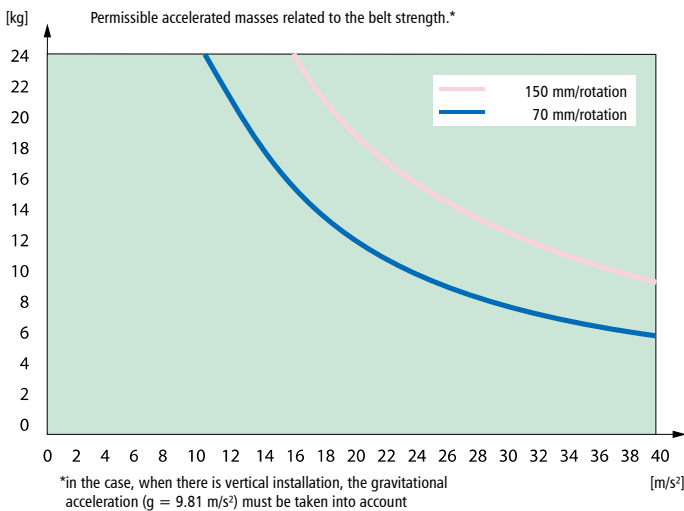

Technical data

Belt type	HTD 5M, width 25 mm
Slide weight	0.940 kg
Weight without drive module	1000 mm $\hat{=}$ 10.5 kg
specific mass of the toothed belt	0.09 kg/m
Carriage weight	2.03 kg
specific guidance on weight	0.648 kg/100 mm
Feed per rotation	70 mm or 150 mm
Effective diameter of the synchronizing pulleys at 70 mm feed/rotation	$\varnothing 22.28$ mm
Effective diameter of the synchronizing pulleys at 150 mm feed/rotation	$\varnothing 47.75$ mm
The synchronizing pulleys have a mass moment of inertia at 70 mm feed/rotation	$5.58 \cdot 10^{-6} \text{ kgm}^2$
The synchronizing pulleys have a mass moment of inertia at 150 mm feed/rotation	$1.796 \times 10^{-4} \text{ kg m}^2$

Order key

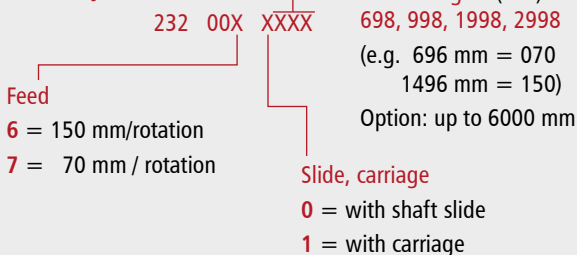



Dimensional drawings
equipped with shaft slide

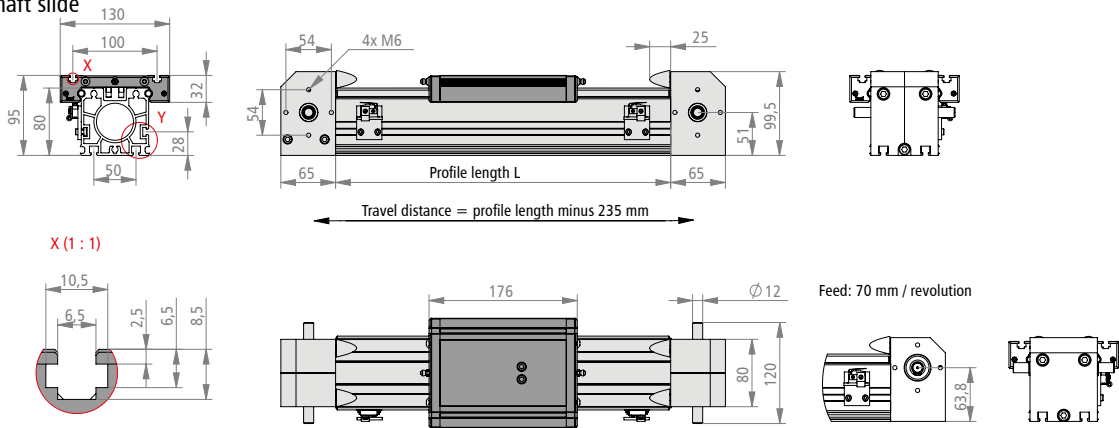

equipped with trolley

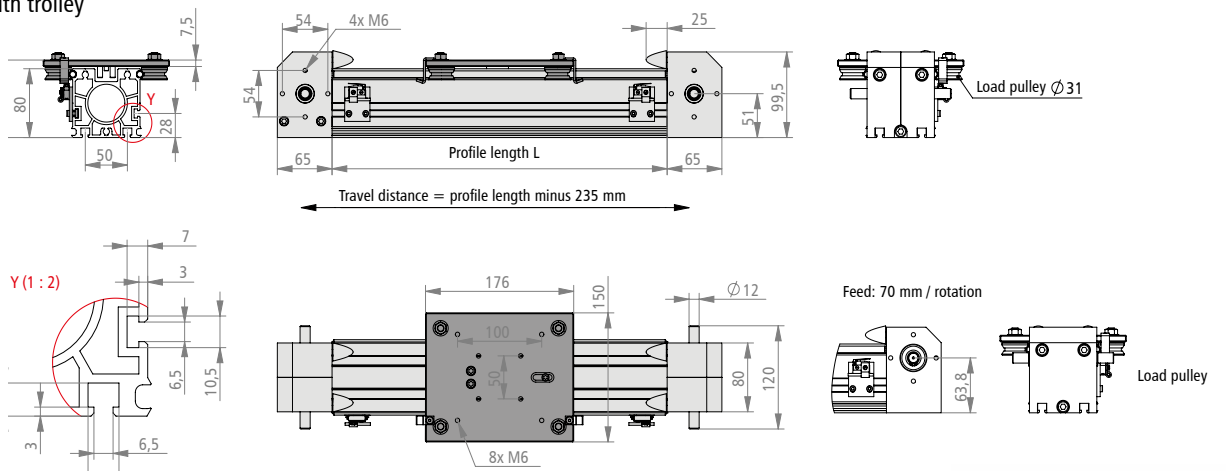

Drive modules

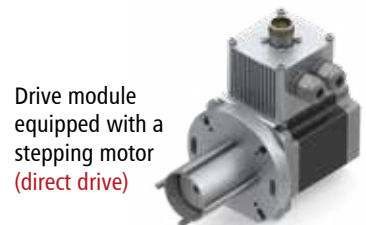
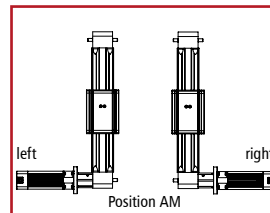
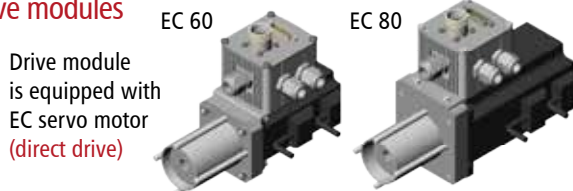

Dimensional drawing EC 60

Part No.	Motor module	Length, L
396421 006012	EC 60TM 200W 48V	103.5 mm
396421 026012	EC 60 TM 200W 48V equipped with brake	150.5 mm
396421 007012	EC 60 TM 200W 310V	107.7 mm
396421 027012	EC 60 TM 200W 310V equipped with brake	154.7 mm
396440 008012	EC 60 TM 400W 48V	131.5 mm
396440 028012	EC 60 TM 400W 48V equipped with brake	178.5 mm
396440 007012	EC 60 TM 400W 310V	135.7 mm
396440 027012	EC 60 TM 400W 310V equipped with brake	178.5 mm

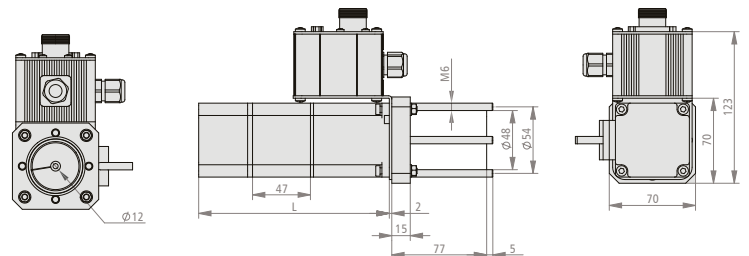

Dimension drawing motor module 2

Part No.	Motor module	L [mm]	H [mm]	H1 [mm]	B [mm]	B1 [mm]
396475 007012	EC 80 TM 750W	143	85	139.5	80	80
396475 027012	EC 80 TM 750W equipped with brake	191				
396085 006012	MS 600 HT	96	91	145.5	90	86
396088 006012	MS 900 HT	126				

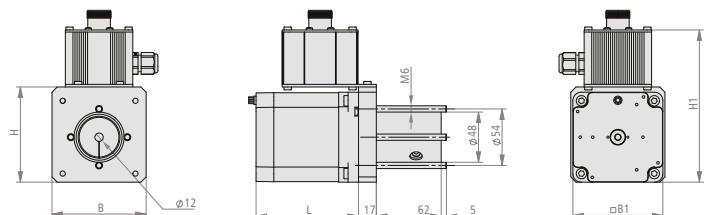



Accessories LEZ

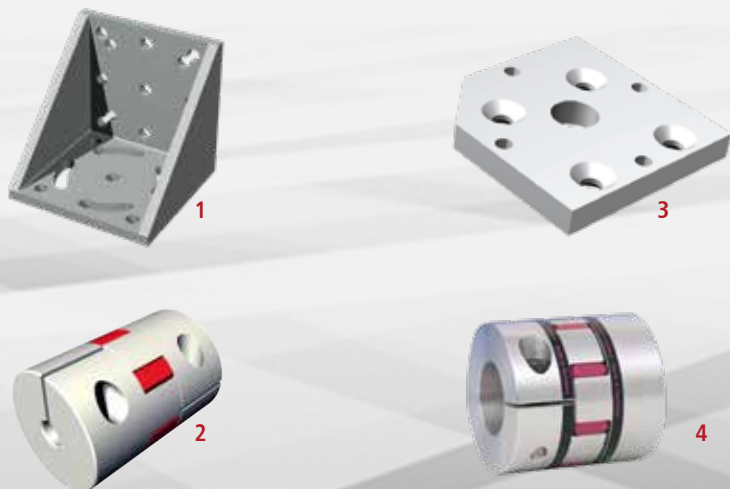

LEZ 1

Wire angle

- made for LEZ 1

Part No.: 209110 0010 (image 1)

20/30 coupling

- made for LEZ 1
- 1 PU = 1 coupling

Part No.: 218001 5081 (image 2)

Shaft slide 1/70

- L 96 x W 72 x H 28.5 mm
- Milled clamping surface, M6 T-slot indentations
- centered Lubrication option, adjustable without clearance
- Weight: 0.35 kg
- Option: stainless design

Part No.: 223100 0070

stainless: 223101 0070

Transmission shaft

Length 1 m

Part No.: 227008 1000

LEZ 2

Motor mounting plate

- made for LEZ 2
- Including mounting material
- made for direct drive

Part No.: 232199 0004 (image 3)

Coupling for the transmission shaft

- made for LEZ 2
- 1 PU = 2 pieces couplings

Part No.: 218050 0002 (image 4)

Transmission shaft Ø 25 mm

Length 1 m

Part No.: 219001 0125

Length 2 m

Part No.: 219001 0225

Pillow block bearing designed for transmission shaft

PU 1 piece

Part No.: 896202 5562

LEZ 3

Coupling for the transmission shaft

- made for LEZ 3
- 1 PU = 2 pieces couplings

Part No.: 218050 0002 (image 5)

Transmission shaft Ø 25 mm

Length 1 m

Part No.: 219001 0125

Length 2 m

Part No.: 219001 0225

Pillow block bearing is designed for transmission shaft

PU 1 piece

Part No.: 896202 5562



Customized special applications

Mechanical components from isel **Flexible & highly efficient**

The custom-made product shown here for engraving brass instruments is based on an aluminum base frame, which impresses with its robustness and durability and forms the foundation for a high-precision axis system. A 3-axis cantilever arrangement consisting of our LES 5 and LES 6 linear units with servomotors forms the heart of the system.

The workpiece is manually fixed on an LES 6 using a handwheel and brought into the desired position by a controlled RDH-M rotation unit. The system is operated via the user-friendly iOP-19 control panel, which was mounted on a mobile stand at the customer's request.

The program is processed using ProNC, an advanced software solution that is renowned for its performance and user-friendliness.



Fig.: „Engraving machine“ for Buffet Crampon

Do you also have an application for which you need our expertise?

Together with our design department and our sales team, we will find a customized solution for you.



Rotary indexing tables / rotary axes

The multi-dimensional processing of a wide variety of workpieces and materials often requires rotary indexing tables and rotary axes as the fourth or fifth axis in addition to the three-axis CNC machine. Whether for small components or higher loads - the maintenance-free isel rotary axes are popular with designers for a wide range of applications and machine sizes. Useful, easy-to-mount accessories such as chucks, T-slot plates and tailstockunits reliably fix the workpiece. Rotary indexing tables and rotary axes are available in different configurations and can be easily retrofitted into existing systems as well.

RDH series



DSH series





Transport loads, machining forces, feed

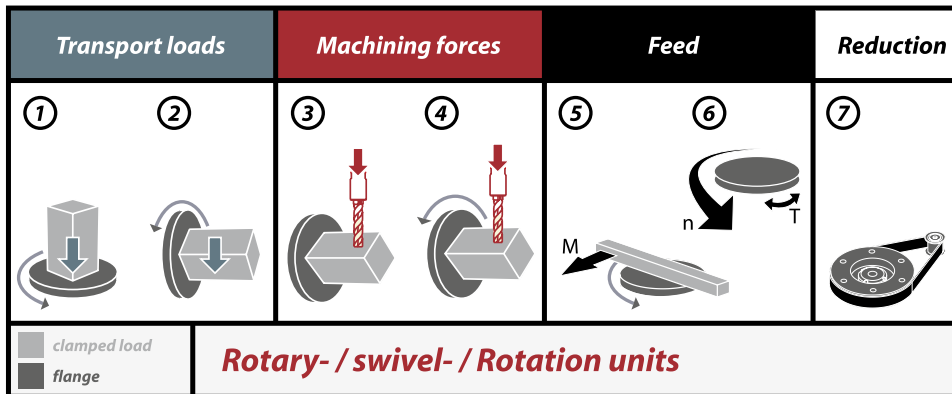

Rotating and/or swiveling units	1*	2*	3	4	5	6	7
RDH-M (step)	100 kg	45 kg	55 Nm	24 Nm	24 Nm	4 rpm	1:51
RDH-M (step)	160 kg	70 kg	108 Nm	45 Nm	45 Nm	2 rpm	1:101
RDH-M (brushless EC servo)	110 kg	50 kg	26 Nm	9 Nm	9 Nm	22 rpm	1:51
RDH-M (brushless EC servo)	180 kg	80 kg	51 Nm	17 Nm	17 Nm	11 rpm	1:101
RDH-S (step)	30 kg	15 kg	7 Nm	7 Nm	7 Nm	4 rpm	1:51
RDH-S (step)	48 kg	24 kg	11 Nm	11 Nm	11 Nm	2 rpm	1:101
RDH-M (brushless EC servo)	30 kg	15 kg	7 Nm	4.6 Nm	4.6 Nm	22 rpm	1:51
RDH-M (brushless EC servo)	48 kg	24 kg	11 Nm	4.6 Nm	9.2 Nm	11 rpm	1:101
RDH-S (DC servo)	25 kg	13 kg	7 Nm	4.6 Nm	4.6 Nm	22 rpm	1:51
RDH-S (DC servo)	40 kg	20 kg	11 Nm	8.7 Nm	8.7 Nm	11 rpm	1:101
RDH-XS (step)	30 kg	10 kg	5 Nm	5 Nm	5 Nm	24 rpm	1:50
RDH-XS (step)	30 kg	10 kg	7 Nm	7 Nm	7 Nm	12 rpm	1:100
RDH-M (brushless EC servo)	30 kg	10 kg	5 Nm	5 Nm	5 Nm	59 rpm	1:50
RDH-M (brushless EC servo)	30 kg	10 kg	7 Nm	7 Nm	7 Nm	30 rpm	1:100
RDH-XS (DC servo)	30 kg	10 kg	5 Nm	5 Nm	5 Nm	70 rpm	1:50
RDH-XS (DC servo)	30 kg	10 kg	7 Nm	7 Nm	7 Nm	35 rpm	1:100
MD 1 (step)	5 kg	2.5 kg	14 Nm	8 Nm	8 Nm	60 rpm	1:20
MD 1 (DC servo)	6 kg	3 kg	3.9 Nm	3 Nm	3 Nm	175 rpm	1:20
MD 1 (brushless EC servo)	6 kg	3 kg	4 Nm	3.2 Nm	3.2 Nm	150 rpm	1:20
ZR 20 (step)	10 kg	5 kg	10 Nm	8 Nm	8 Nm	60 rpm	1:20
ZD 30 (step)	14 kg	8 kg	15 Nm	12 Nm	12 Nm	40 rpm	1:30

*Guide values varying according to the application



Rotary indexing table/rotary axis RDH-XS

- Equipped with precision gear
 - heavy duty and stiff output bearing
 - Clearance-free and high torsional rigidity
- Reduction ratio of 1:50 or 1:100
- Stepping or servo motor
- Cable outlet on the right or left side
- Degree of protection IP 65
- Stainless construction
- Accuracy of transmission <2.0 arcmin
- Repeatability <±1.0 arcmin
- Maintenance-free

RDH-XS as rotary indexing table



RDH-XS as axis of rotation

Order key

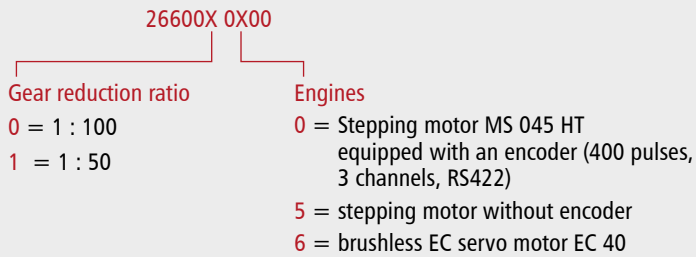

Accessories



Clamping chuck
 3-jaw chuck Ø 65
 Part No.: 269060 4065*

*including flange



Tailstock unit
 RE-XSfor RDH-XS
 Part No.: 269100 0020 (200 mm)
 Part No.: 269100 0030 (300 mm)
 Part No.: 269100 0040 (400 mm)
 Part No.: 269100 0050 (500 mm)



Technical data

	Stepping motor MS 045 HT*		EC servo motor EC 40	
	1:50	1:100	1:50	1:100
Reduction ratio of gear	1:50	1:100	1:50	1:100
Nominal output speed [1/min]	5	2	60	30
	at 1,500 Hz (225 1/min)		at 3,000 rpm	
Max. Output speed [1/min]	24	12	100	50
	at 8,000 Hz (1200 rpm)		at 5,000 rpm	
Rated torque [Nm]	5	7	5	7
	at 1500 Hz (225 1/min)		-	
Max. torque (for a short term) [Nm]	-	-	9	14
Nominal holding torque (static load) [Nm]	5	7	5	7
Max. load capacity of the gearbox [Nm]	9	14	9	14
	Limit for repeatable peak torque			
Dynamic load rating C [N]			392	
Static load rating c ₀ [N]			392	
Weight [kg]			2.3	

*Values for the half-step mode

Dimensional drawings RDH-XS rotary axis

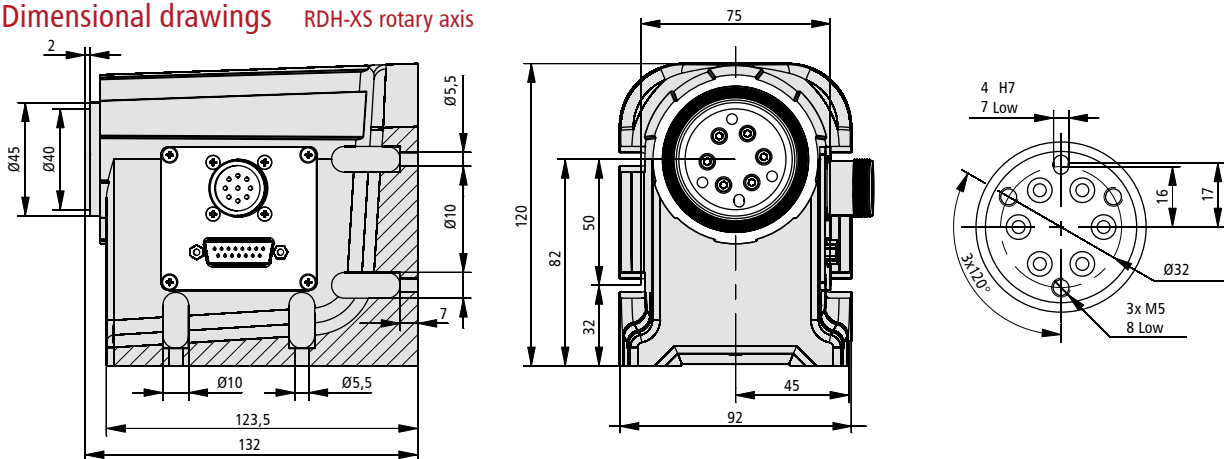

Variants

	Item number	L	A
Tailstock unit RE-XS 200 mm	269100 0020	325	117
Tailstock unit RE-XS 300 mm	269100 0030	425	217
Tailstock unit RE-XS 400 mm	269100 0040	525	317
Tailstock unit RE-XS 500 mm	269100 0050	625	417

Tailstock unit RE-XS

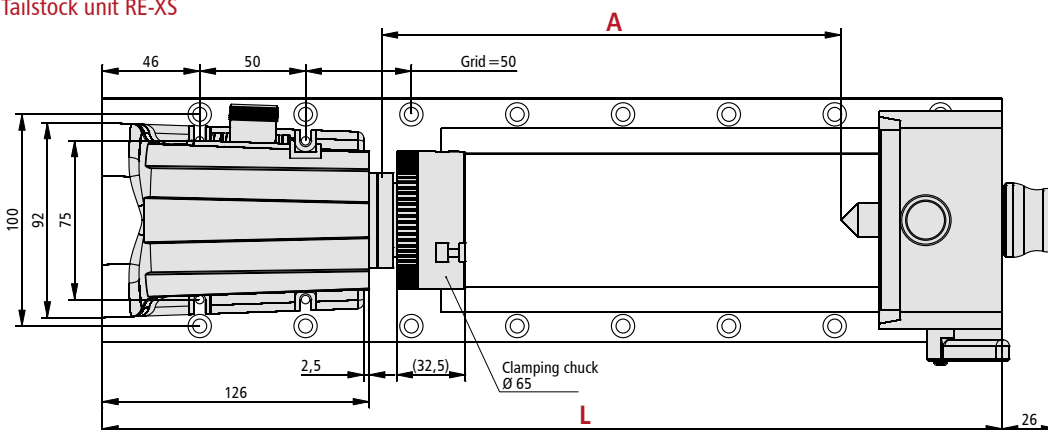



Rotary indexing tables/rotary axis RDH-S

- Equipped with precision gear
 - heavy duty and stiff output bearing
 - Clearance-free and high torsional rigidity
- Reduction ratio of 1:51 oder 1:101
- Stepping or servo motor
- Cable outlet on the right or left side
- Degree of protection IP 65
- Stainless construction
- Transmission accuracy < 1.5 arcmin
- Repeatability < ±6 arcsec
- Optionally as a solid shaft or with a hollow shaft design
- Maintenance-free



Order key

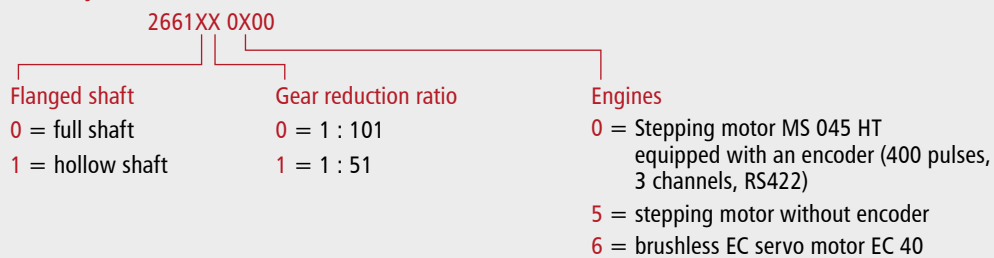

Accessories



Clamping chuck
3-jaw chuck Ø 65
Part No.: 269060 3065*

3-jaw chuck Ø 80
Part No.: 269063 2080*

3-jaw chuck Ø 100
Part No.: 269063 2100*

*including flange



Round plates
Ø 150 mm
Part No.: 269050 0150



Tailstock unit RE-S
for RDH-S
Part No.: 269100 1020 (200 mm)
Part No.: 269100 1030 (300 mm)
Part No.: 269100 1040 (400 mm)
Part No.: 269100 1050 (500 mm)



Technical data

	Stepping motor MS 045 HT*		EC servo motor EC 40	
	1:51	1:101	1:51	1:101
Reduction ratio of gear	4	2	22	11
Nominal output speed [1/min]	at 1,500 Hz (225 1/min)		at 1,100 1/min	
Max. Output speed [1/min]	24	12	98	50
	at 8,000 Hz		at 5,000 rpm	
Rated torque [Nm]	7	11	4.8	9.2
	at 1,500 Hz		-	
Max. torque (for a short term) [Nm]	-	-	7	11
Nominal holding torque (static load) [Nm]	7	11	7	11
Max. load capacity of the gearbox [Nm]	18	28	18	28
	Limit for repeatable peak torque			
Dynamic load rating C [N]			5,800	
Static load rating c_0 [N]			8,600	
Weight [kg]			4.6	

*Values for the half-step mode

Dimensional drawings RDH-S rotary axis

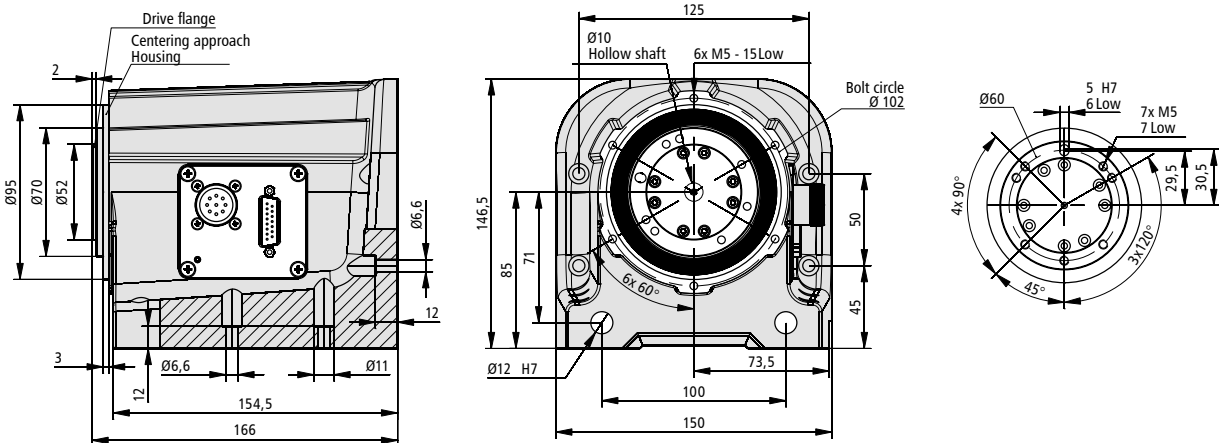

Variants

	Item number	L	A
Tailstock unit RE-S 200 mm	269100 1020	370	128
Tailstock unit RE-S 300 mm	269100 1030	470	228
Tailstock unit RE-S 400 mm	269100 1040	570	328
Tailstock unit RE-S 500 mm	269100 1050	670	428

Tailstock unit RE-S

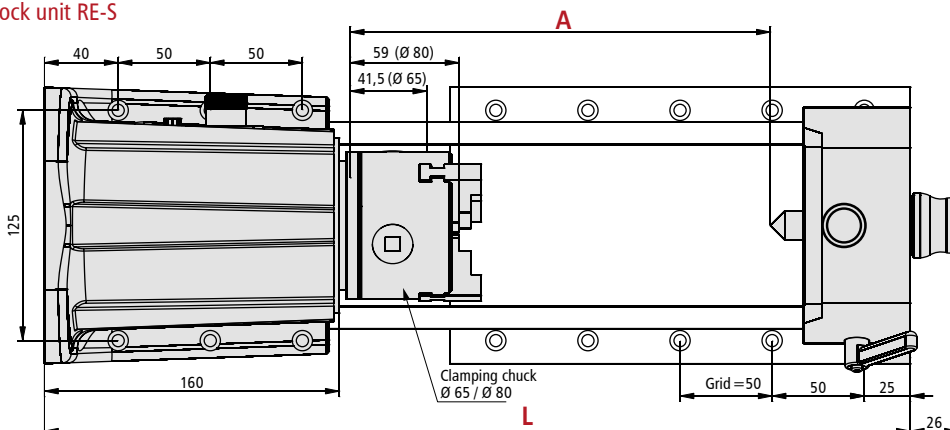



Rotary indexing tables/rotary axis RDH-M

- Equipped with precision gear
 - heavy duty and stiff output bearing
 - Clearance-free and high torsional rigidity
- Reduction ratio of 1:51 oder 1:101
- Stepping or servo motor
- Cable outlet on the right or left side
- Degree of protection IP 65
- Stainless construction
- Transmission accuracy < 1 arcmin
- Repeatability < ±6 arcsec
- Optionally as a solid shaft or with a hollow shaft design
- Maintenance-free



RDH-S as rotary indexing table
(hollow shaft version)



RDH-S as rotary axis
(hollow shaft version)

Order key

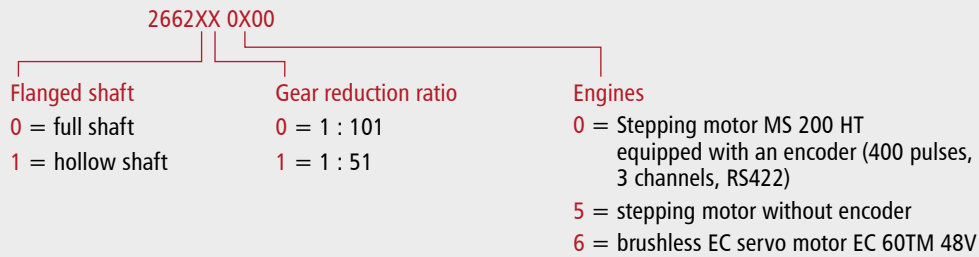

Accessories



Clamping chuck
3-jaw chuck Ø 125
Part No.: 269063 2125*

*including flange



Aluminum T-slot plate
Ø 240 mm / PT 25
Part No.: 269050 0240

Ø 365 mm / PT 25
Part No.: 269050 0365



Tailstock unit RE-M
for RDH-M
Part No.: 269100 2100 (1000 mm)
Part No.: 269100 2150 (1500 mm)
Part No.: 269100 2200 (2000 mm)



Technical data

**Stepping motor
MS 200HT***

**EC servo motor
EC 60TM (brushless)**

Reduction ratio of gear	1:51	1:101	1:51	1:101
Nominal output speed [1/min]	4	2	20	10
	at 1,500 Hz (225 1/min)		at 1,000 1/min	
Max. Output speed [1/min]	24	12	78	40
	at 8,000 Hz		at 4,000 1/min	
Rated torque [Nm]	24	46	20	38
	at 1,500 Hz		-	
Max. torque (for a short term) [Nm]	-	-	42	80
Nominal holding torque (static load) [Nm]	55	108	26	51
Max. load capacity of the gearbox [Nm]	98	157	98	157
	Limit for repeatable peak torque			
Dynamic load rating C [N]	21800			
Static load rating c ₀ [N]	35800			
Weight [kg]	13.7			

*Values for the half-step mode

Dimensional drawings Axis of rotation RDH-M

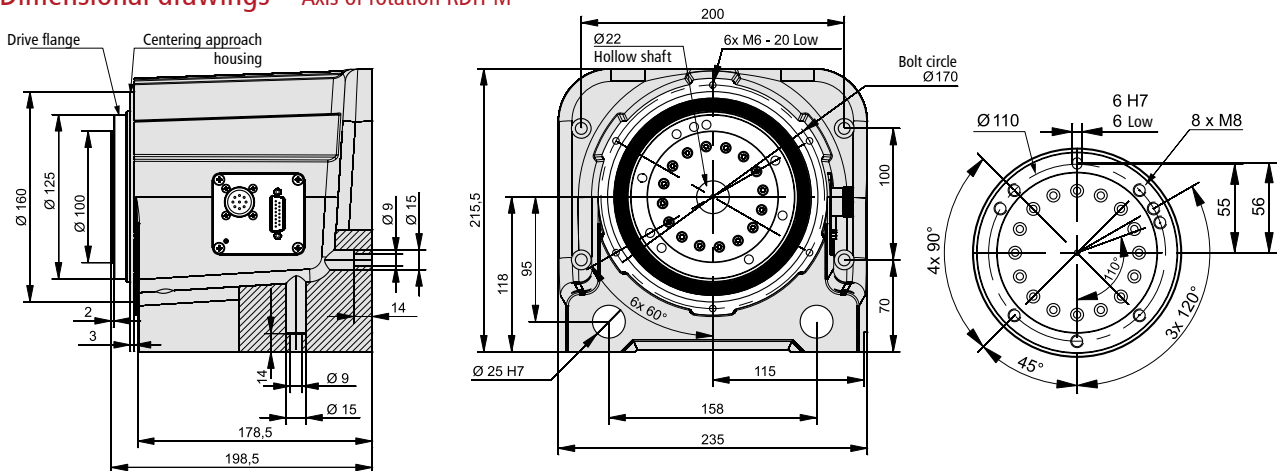

Variants

Item number

L

A

Tailstock unit RE-M 1000 mm	269100 2100	1110	624.5
Tailstock unit RE-M 1500 mm	269100 2150	1610	1124.5
Tailstock unit RE-M 2000 mm	269100 2200	2110	1624.5

Tailstock unit RE-M

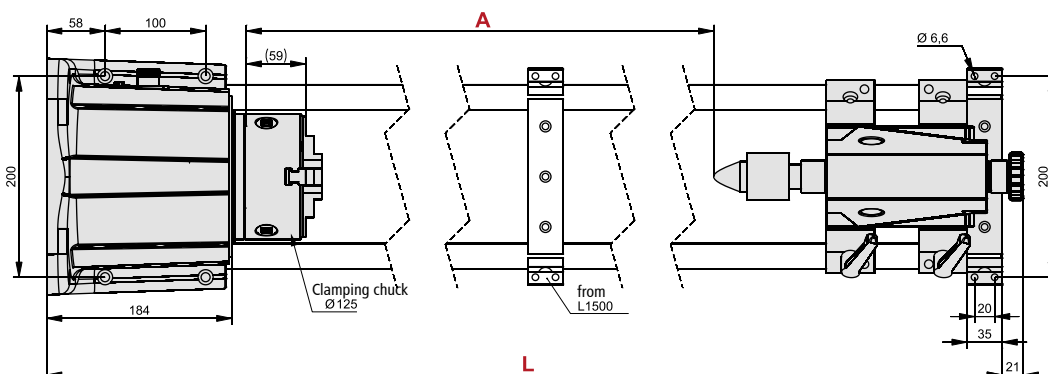



Indexing table RF 1

- Low play toothed belt drive with stepper or DC servo motor
- Reduction 1: 24 (standard)
- Weight: 14.6 kg

Options:

- Reduction installation set 1 : 52 or 1 : 100
- Electromagnetic brake [60 Nm]
- Step motor drive with encoder CNC controller



Order key

26024X XX00

Motore

- 1 = Stepper motor MS 200 HT without encoder
- 4 = brushed DC servomotor DC 100
- 5 = brushless EC servomotor EC 60S

Brake

- 0 = without brake
- 1 = magnetic brake

Anschlusstecker

- 1 = servomotor: M23 + SubD15
- 2 = Stepper motor: SubD9
- 3 = Stepper motor: M23

Accessories



Installation set
for reduction 1:52
Part no.: 269077 0001

for reduction 1:100
Part no.: 269077 0002



Aluminium T-slot plate
Ø 240 mm / PT 25
Part no.: 269050 0240

Ø 365 mm / PT 25
Part no.: 269050 0365



Chuck assembly
3-jaw chuck Ø 125
Part no.: 269063 2125



Technical data	stepper motor MS 200 HT*			servo motor DC 100 / EC 60S		
	1:24	1:52	1:100	1:24	1:52	1:100
Reduction ratio	1:24	1:52	1:100	1:24	1:52	1:100
Output speed [1/min]	0 - 50	0 - 23	0 - 12	0 - 125	0 - 58	0 - 30
Operating torque (0 - 500 Hz) [Nm]	20	42	75	-		
Operating torque (500 - 1000 Hz) [Nm]	18	38	75	-		
Rated torque [Nm]	-			6 / 10	13 / 22	25 / 42
Rated holding torque (static load) [Nm]	37	75	75	7 / 12	16 / 26	30 / 50
Angle accuracy [°]				0,16		
Weight [kg]				14,6		

* Values for half-step operation

Dimensional drawings

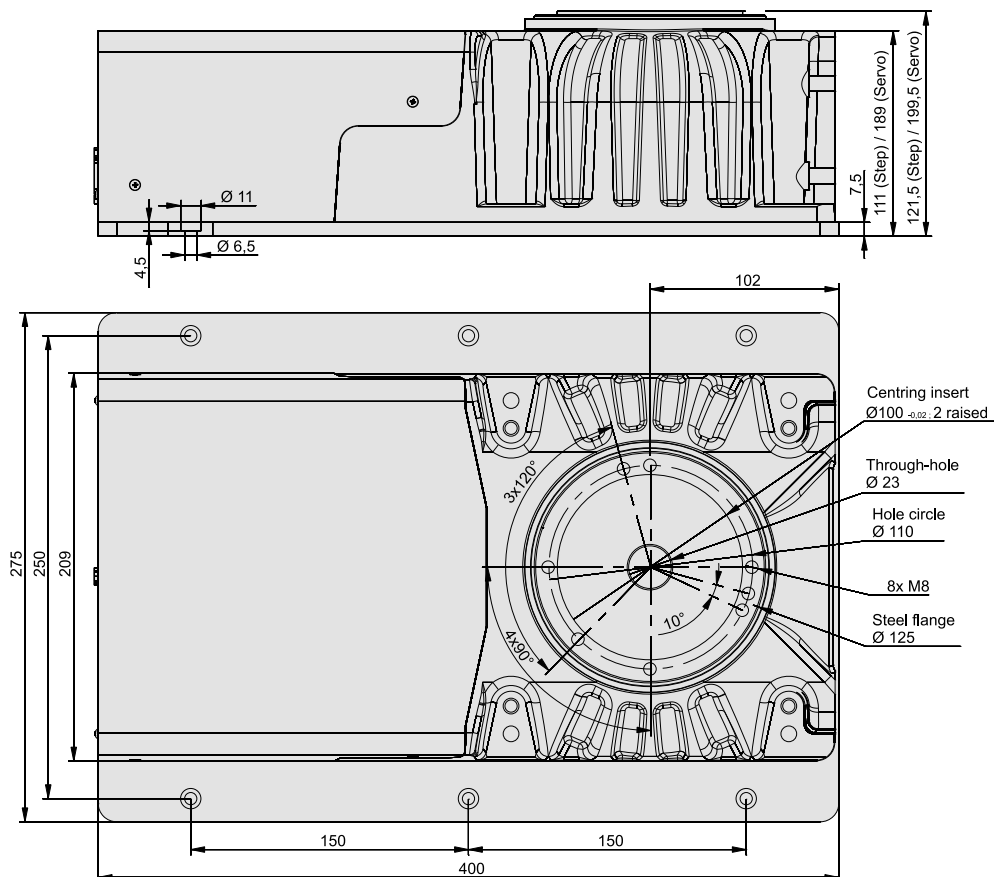



Indexing table ZR 20

- Low play toothed belt drive with stepper motor
- Reduction 1 : 20
- Shaft with Ø 15 mm boring
- Housing flange with inner cone SK 20
- Weight: 2.1 kg

Options:

- CNC controller via Sub D

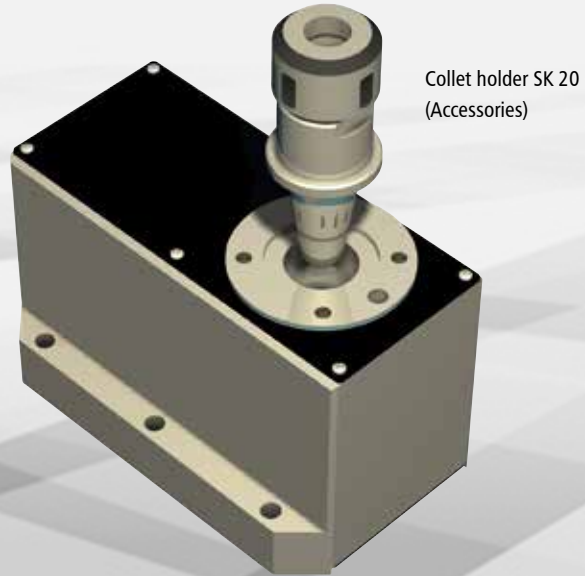

Ordering data

ZR 20 Indexing table
Part no.: 260300 0000

Accessories



Chuck assembly
3-jaw chuck Ø 65
Part no.: 269060 2065



Clamping ring housing SK 20
for tools Ø 3 - 13 mm,
with installation ring
Part no.: 239122 0001

for tools Ø 3 - 12,7 mm,
with installation ring
Part no.: 239122 9001

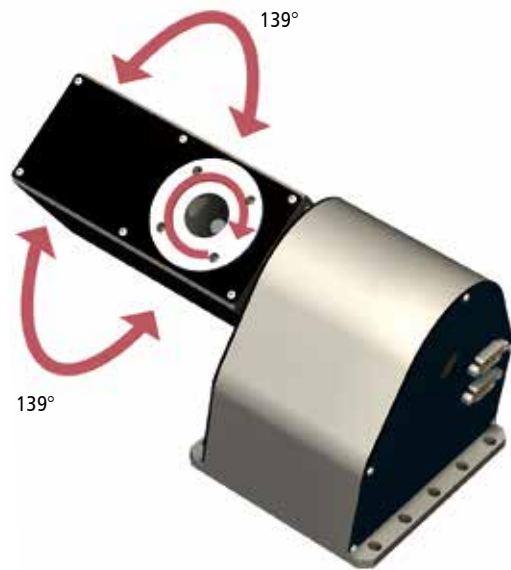

The rotary tilting unit ZDS 2030 can be used as a 4th/5th axis in CNC machines for fine workshops or in the handling area. It is a combination of ZD 30 and the modified version of ZR 20. ZDS 2030 enables 5-side machining or free-form surface machining on a conventional 3-axis system of easily machinable materials (e.g. plastic). The tilting angle is 139° in both directions.

Rotary tilting unit ZDS 2030
Part no.: 265 000 0000



Technical data

stepper motor MS 050 HT *

Reduction ratio	1:20
Output speed [1/min]	0 - 60
Operating torque (0 - 1600 Hz) [Nm]	8
Rated holding torque (static load) [Nm]	14
Min. step (positional accuracy) [arcmin]	3.5
Weight [kg]	2.1

* Values for half-step operation

Dimensioned drawing

ZR 20

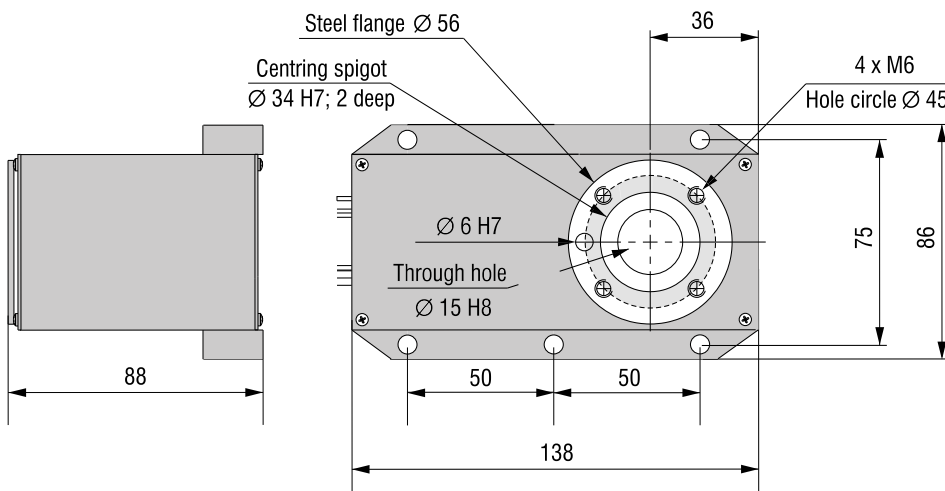

ZDS2030

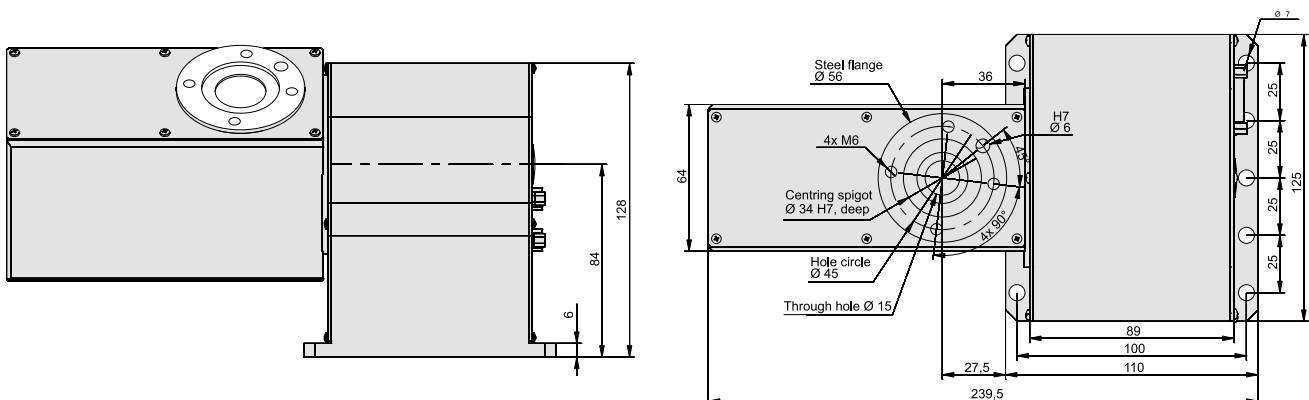



Rotary swivel unit type DSH-S

- Equipped with precision gear
 - heavy duty and stiff output bearing
 - Clearance-free and high torsional rigidity
- equipped with rotary axis type RDH-S
- Reduction ratio of 1:51 oder 1:101
- Stepping or servo motor
- Degree of protection IP 65
- Stainless construction
- Transmission accuracy <math>< 1.5 \text{ arcmin}</math>
- Repeatability <math>< \pm 6 \text{ arcsec}</math>
- Maintenance-free
- Infinitely adjustable swivel range



Order key

26541X X000

Engines

- 0 = Stepping motor MS 045 HT equipped with an encoder (400 pulses, 3 channels, RS422)
- 5 = stepping motor without encoder
- 6 = brushless EC servo motor EC 40

Gear reduction ratio

- 0 = 1 : 101
- 1 = 1 : 51

Accessories



Clamping chuck

3-jaw chuck \varnothing 65
Part No.: 269060 3065*

3-jaw chuck \varnothing 80
Part No.: 269063 2080*

3-jaw chuck \varnothing 100
Part No.: 269063 2100*

*including flange



Round plates

\varnothing 150 mm
Part No.: 269050 0150



Technical data

	Stepping motor MS 045 HT*		EC servo motor EC 40	
	1:51	1:101	1:51	1:101
Reduction ratio of gear	4	2	22	11
Nominal output speed [1/min]	at 1,500 Hz (225 1/min)		at 1,100 1/min	
Max. Output speed [1/min]	24	12	98	50
	at 8,000 Hz		at 5,000 rpm	
Rated torque [Nm]	7	11	4.8	9.2
	at 1,500 Hz		-	
Max. torque (for a short term) [Nm]	-	-	7	11
Nominal holding torque (static load) [Nm]	7	11	7	11
Max. load capacity of the gearbox [Nm]	18	28	18	28
	Limit for repeatable peak torque			
Dynamic load rating C [N]			5,800	
Static load rating c ₀ [N]			8,600	
Weight [kg]			12	

*Values for the half-step mode

Dimensional drawings

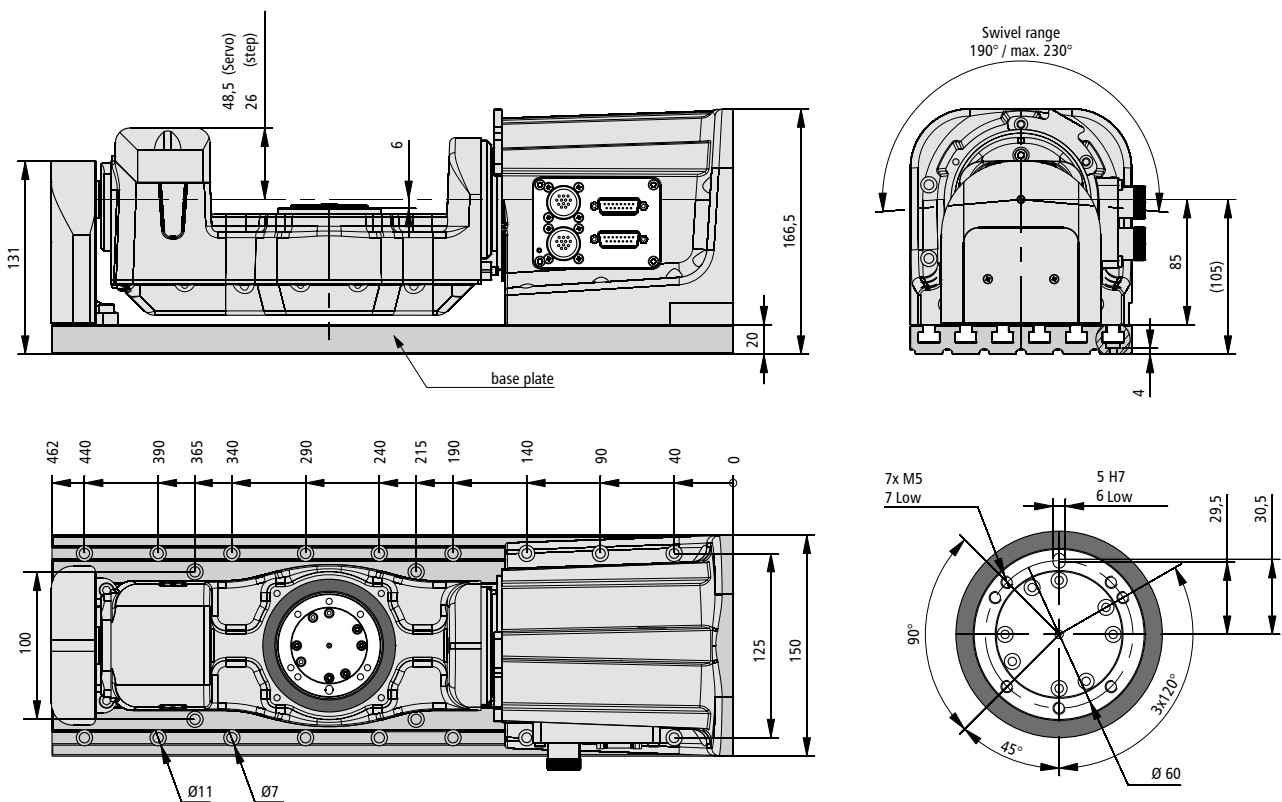



Rotary swivel unit type DSH-M

- Equipped with precision gear
 - heavy duty and stiff output bearing
 - Clearance-free and high torsional rigidity
- equipped with rotary axis type RDH-M
- Reduction ratio of 1:51 oder 1:101
- Stepping or servo motor
- Degree of protection IP 65
- Stainless construction
- Transmission accuracy < 1 arcmin
- Repeatability < ±6 arcsec
- Maintenance-free
- Infinitely adjustable swivel range

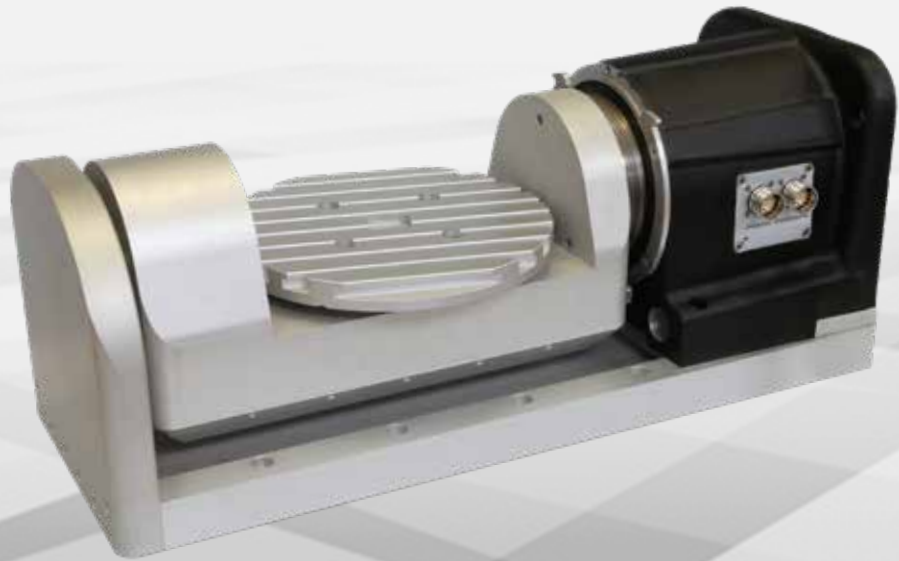

Order key

26542X X000

Engines

- 5 = stepping motor type MS 200 HT
- 6 = brushless EC servo motor EC 60TM

Gear reduction ratio

- 0 = 1 : 101
- 1 = 1 : 51

Accessories



Clamping chuck
3-jaw chuck Ø 125
Part No.: 269063 2125*



Aluminum T-slot plate
Ø 240 mm / PT 25
Part No.: 269050 0240

*including flange



Technical data

**Stepping motor
MS 200HT***

**EC servo motor
EC 60TM**

Reduction ratio of gear	1:51	1:101	1:51	1:101
Nominal output speed [1/min]	4	2	20	10
	at 1,500 Hz (225 1/min)		at 1,000 1/min	
Max. Output speed [1/min]	24	12	78	40
	at 8,000 Hz		at 4,000 1/min	
Rated torque [Nm]	24	46	20	38
	at 1,500 Hz		-	
Max. torque (for a short term) [Nm]	-	-	42	80
Nominal holding torque (static load) [Nm]	55	108	26	51
Max. load capacity of the gearbox [Nm]	98	157	98	157
	Limit for repeatable peak torque			
Dynamic load rating C [N]				21800
Static load rating c ₀ [N]				35800
Weight [kg]				

*Values for the half-step mode

Dimensional drawings

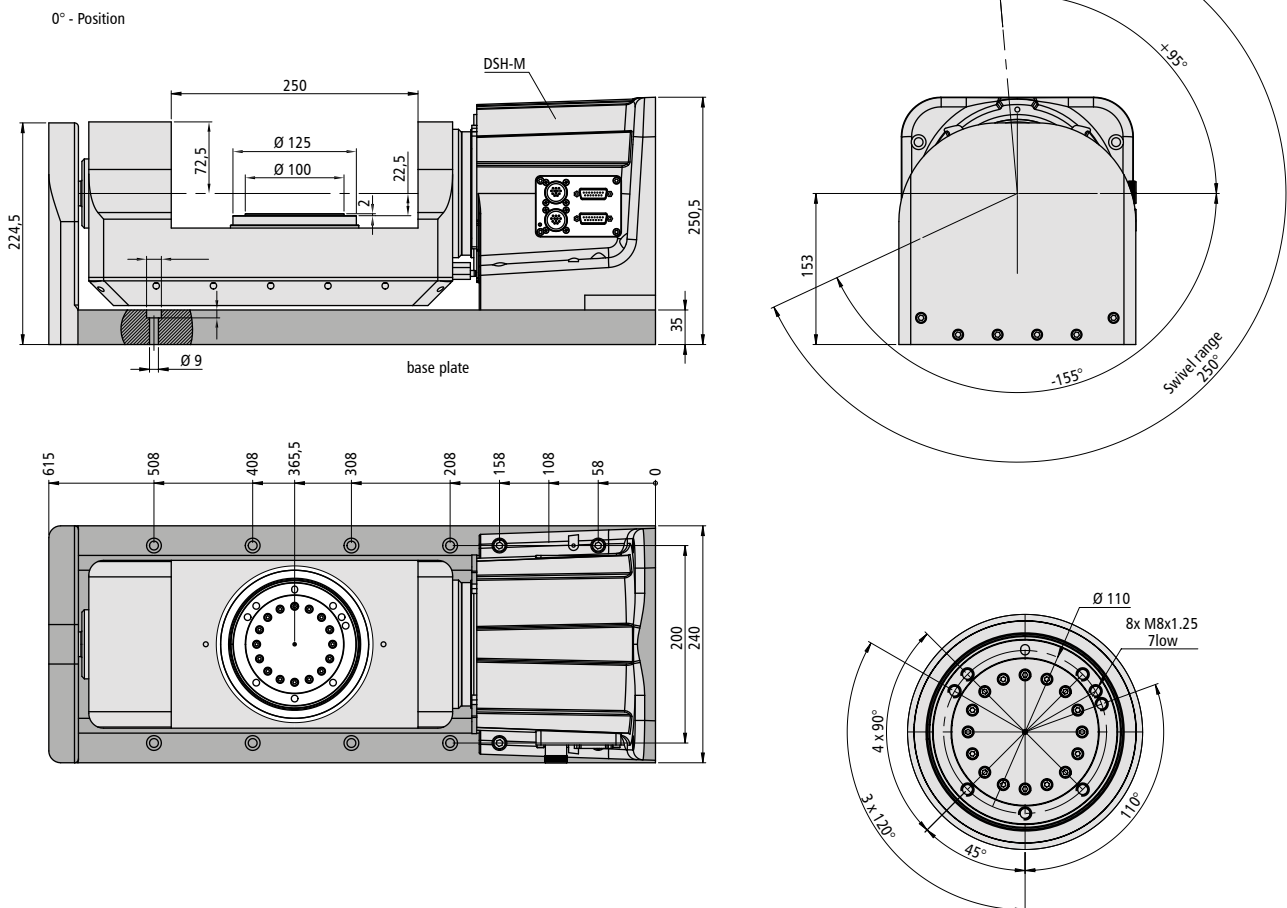



Rotary axis type ZD30

- Low toothed belt drive without clearance and equipped with a stepper motor
- Reduction 1 : 30
- Shaft with through hole, Ø 15 mm
- Mounting flange with inner cone SK 20
- Weight: 2.9 kg

Options

- CNC control through Sub-D

Order data

Part No.: 261100 0000

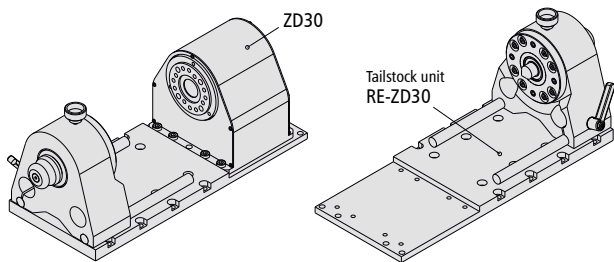
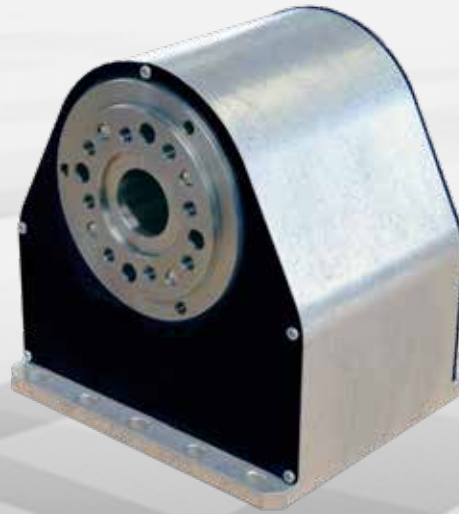

Tailstock unit RE-ZD30 equipped with three-jaw chuck Ø 65

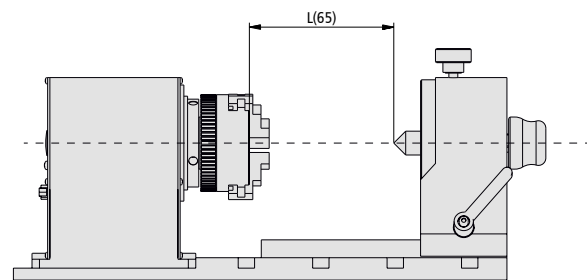

Tailstock unit RE-ZD30 equipped with three-jaw chuck Ø 80

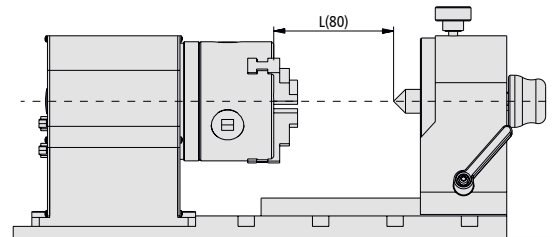

Accessories



Clamping chuck
3-jaw chuck Ø 65
Part No.: 269060 2065*



Clamping chuck
3-jaw chuck Ø 80
Part No.: 269063 3080*



Collet holder
Collet holder SK 20 for
tools Ø 3 - 13 mm,
equipped with mounting ring

Part No.: 239122 9001



Tailstock unit type RE-ZD30

- 200 mm length 331 mm
Part No.: 269 100 1060
- 300 mm length 431 mm
Part No.: 269 100 1070
- 400 mm length 531 mm
Part No.: 269 100 1080
- 500 mm length 631 mm
Part No.: 269 100 1090

*including flange

3-jaw chuck Ø 125
Part No.: 269063 1125*

*including flange



Technical data

Stepping motor type MS 045 HT*

Reduction ratio of gear	1:30
Output speed [1/min]	0 – 40
Operating torque (0 - 1600 Hz) [Nm]	12
Nominal holding torque (static load) [Nm]	20
Min. Increment [arcmin]	2.5
Repetitive accuracy	0.015°
Max. reverse play	0.1°
Transmission accuracy	0.15°
Axial runout at the drive flange [mm]	0.05
Concentricity at the output flange [mm]	0.05
Weight [kg]	2.9

*Values for the half-step mode

Dimensional drawings Rotary axis type ZD30

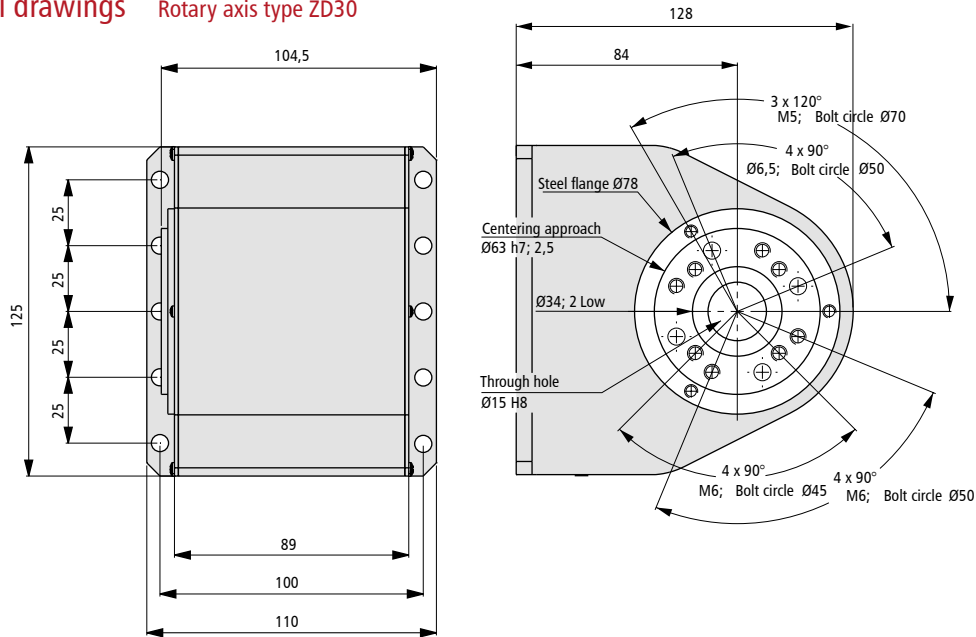

Tailstock unit type RE-ZD30

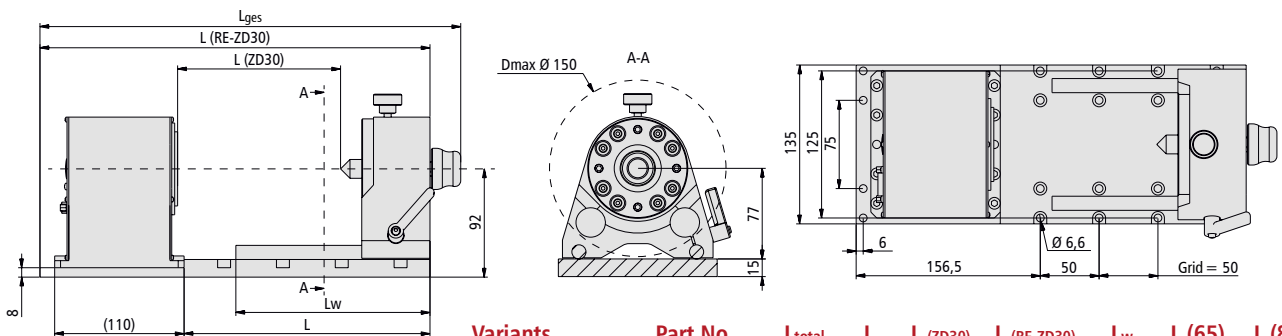

Variants	Part No.	Ltotal	L	L (ZD30)	L (RE-ZD30)	Lw	L (65)	L (80)
RE-ZD30 200 mm	269100 1060	358	209	138.5	331.5	165	97	80.5
RE-ZD30 300 mm	269100 1070	458	309	238.5	431.5	265	197	180.5
RE-ZD30 400 mm	269100 1080	558	409	338.5	531.5	365	297	280.5
RE-ZD30 500 mm	269100 1090	658	509	438.5	631.5	465	397	380.5



Mini rotary axis type MD 1

- Clearance-poor toothed belt drive equipped with stepping motor
- Reduction 1 : 20
- Shaft with through hole, Ø 9 mm
- Mounting flange with inner cone SK 20
- Weight: according to the version, starting from 1.35 kg

Options

- Additional mounting plate (vertical mounting possible) CNC control

Order data

Part No. 261010 0010

Mini rotary axis type MD 1 equipped with optional accessories 3-jaw chuck Ø65 mm

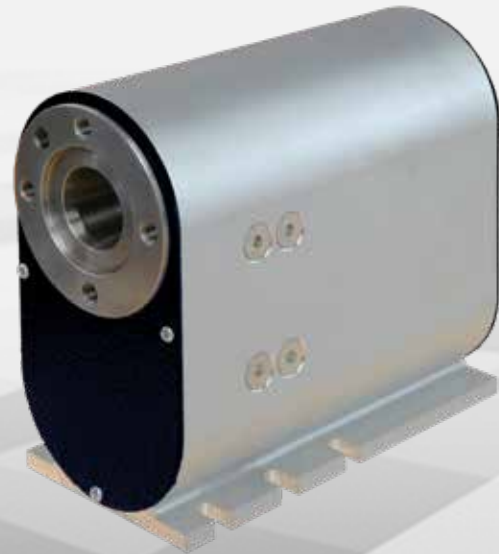

Mounting plate (vertical assembly of the closed construction) Part No.: 277026

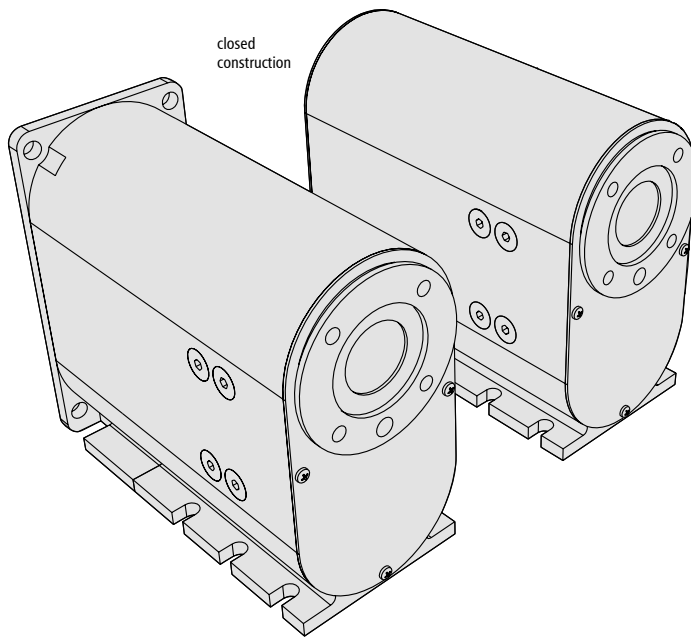

Accessories



Clamping chuck
3-jaw chuck Ø 65
Part No.: 269060 2065*



Collet holder
Collet holder SK 20 for tools Ø 3 - 13 mm, equipped with mounting ring

*including flange

Part No.: 239122 9001





Technical data
**Stepping motor type
MS 048 HT***

Reduction ratio of gear	1:20
Output speed [1/min]	0 - 60
Operating torque (0 - 1600 Hz) [Nm]	8
Rated torque [Nm]	–
Nominal holding torque (static load) [Nm]	14
Min. Increment [arcmin]	3.5
Weight [kg]	1.35

*Values for the half-step mode

Dimensional drawings
length [L] at
Stepping motor

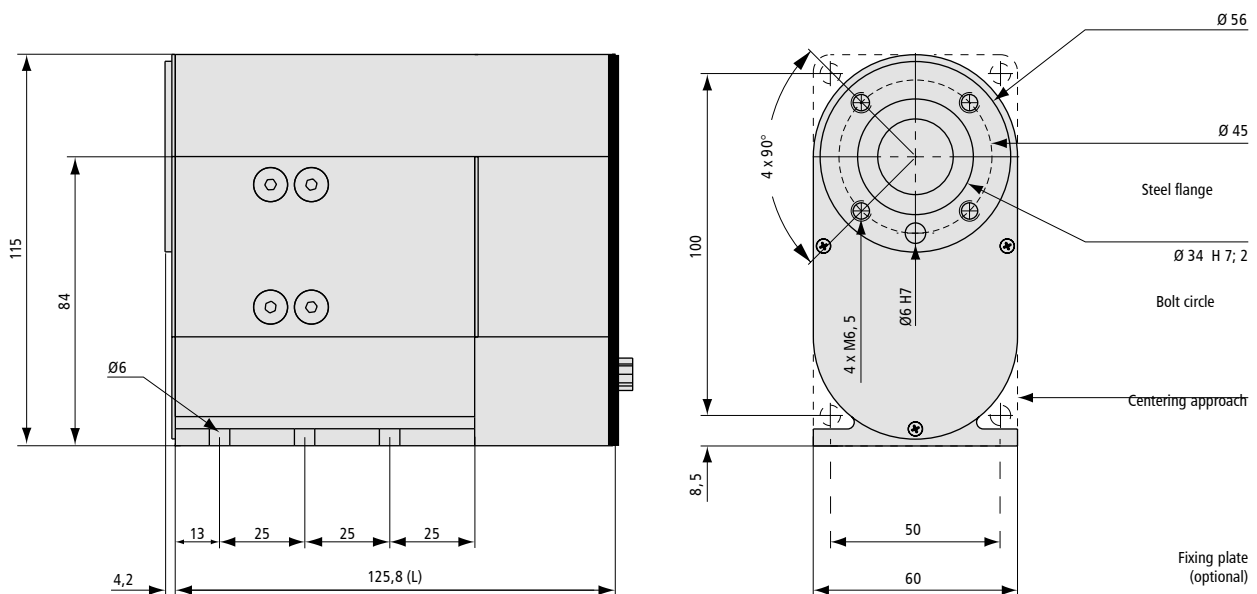
closed construction	129 mm
equipped with fixing plate	130 mm





The proper guide for every machine

High rigidity, load capacity for dynamic traversing and positioning movements, long-term accuracy and low-noise operation: The modern isel linear guide systems made of aluminum with non-rotating precision steel shafts meet the high performance requirements needed for the construction and operation of machines.

In combination with the ball-guided carriages or roller-guided carriages offered in various designs and with an extensive range of accessories, the product range offers solutions for many potential applications and the construction of complex multi-axis systems.

Aluminum shaft slide

The shaft slides manufactured by isel are ideal for the set-up of complex multi-axis systems for handling and processing. Many application areas are covered by a wide range of models.

All models can be manufactured with different profile lengths (of 70, 100, 150, and 200 mm)

The adjustment of the slide is carried out by means of self-locking adjusting screws. For this purpose, the rows of balls and shafts or wires are set against each other and consequently pre-stressed. The carriages are set to the respective pre-loads at the factory. As an option, all shaft slides are available in a stainless version.

To fasten transport loads, slide plates etc., the shaft slides are supplied with T-grooves or fastening holes.

Ball circuits are positioned inside the linear slide. Load-bearing balls each run between two ground steel wires and the guide shaft.

The ball deflection is equipped with a reinforcement made of glass fiber.

Two-sided lubrication option for the ball circuits.

Precision steel shafts reaching a hardness value of 60 ± 2 HRC are used as guide rails. All LFS-8 versions are optionally available with stainless steel shafts.

The base supports of all linear guides are thrust with aluminum profiles according to the standard DIN EN 12020-2 which are provided with T-grooves and/or have fastening holes permitting their fastening inside the profile base

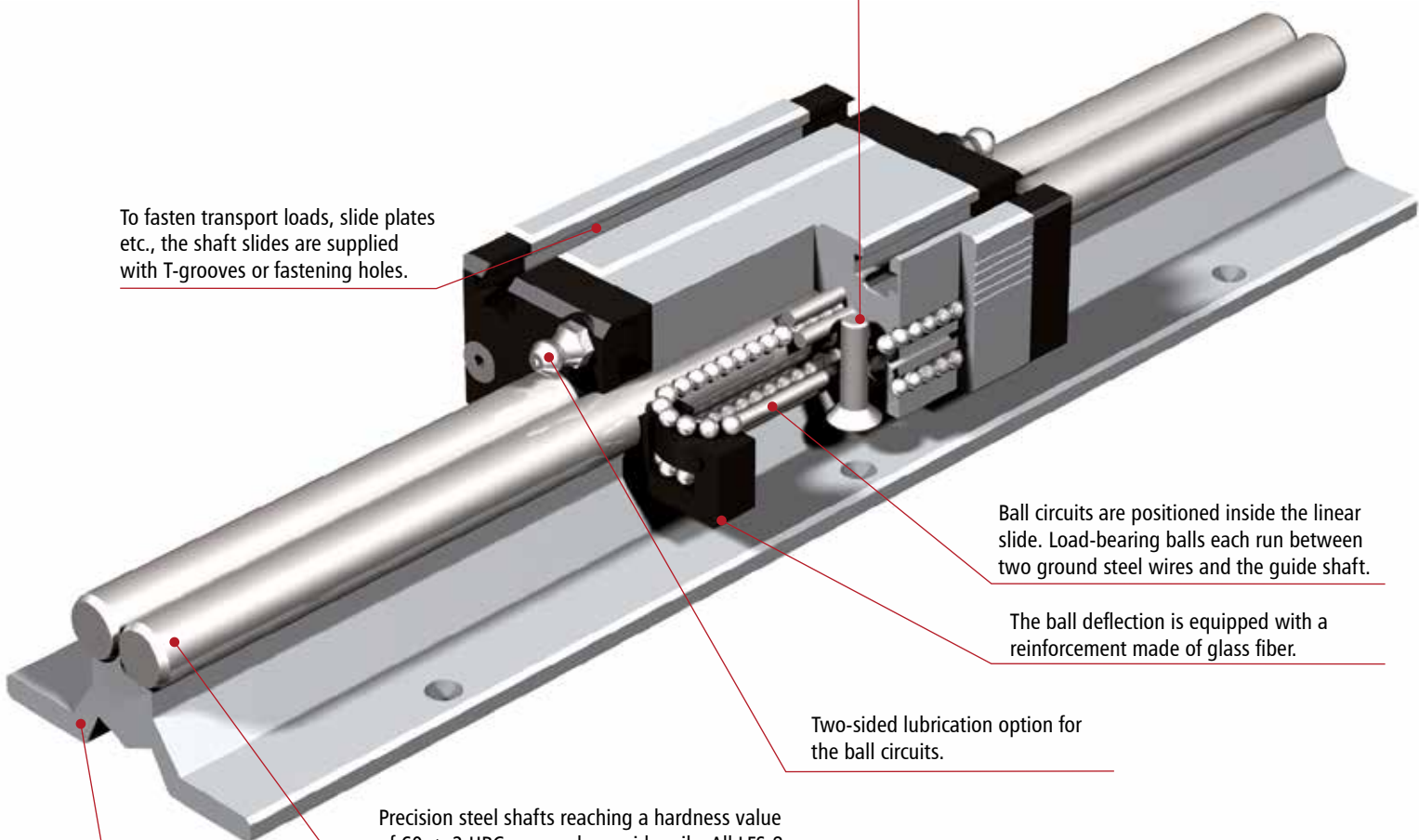



Load capacity and life-time

Assembly position

Generally speaking, the assembly position of the linear guides can be freely selected. What must be considered is just the fact that all exercised forces and moments are below the maximum values for the respective axes.

Temperatures

All linear guides are designed for continuous operation in ambient temperatures of up to 60 °C. In short-term operation, temperatures of a maximum of 80 °C are permissible. The linear guides are not suitable for temperatures below freezing.

Straightness / Torsion

The aluminum profiles used are extruded profiles, which due to the manufacturing process show deviations in terms of straightness and torsion. The tolerance of this deviation is defined according to the standard DIN EN 12020-2. In the worst case, the deviations of the linear guides correspond to these limit values. However, they are usually undercut. In order to achieve the desired guide accuracy, it is necessary to carry out the alignment of the guide by means of leveling plates and/or to clamp it on a suitably precisely machined support surface. In this manner, tolerances of 0.1 mm/1000 mm can be achieved.

Fundamentals of load capacity and service life

The dimensioning of a linear guide is based on the load capacity of the single elements. The carrying capacity is described by:

- the dynamic load rating C
- the static load rating C0
- the static moments M0X , M0Y and M0Z

The basis of the dynamic load ratings according to the DIN standard is a nominal service life of 100,000 m displacement. Suppliers from the Far East often state the load ratings for a nominal service life of 50,000 m; this results in load ratings which are 20% higher than the ratings according to the DIN standard.

Dynamic Capacity

The fatigue behaviour of the material determines its dynamic load capacity. The service life - the fatigue period - depends on the following factors:

- the load of the linear guide
- the travel speed of the linear guide
- the statistical randomness of the first occurrence of damage

Service life

The service life is understood to mean the service life which is actually achieved by a linear guide.

The service life may deviate from the calculated service life. The following situation can result in a premature failure due to wear or in fatigue:

- An existing misalignment between the guide rails or the guide elements
- The soiling of the guide rails
- Insufficient lubrication
- Oscillating movement with very small strokes (corrugation)
- Vibrations during the shutdown (corrugation)

Because of the variety of the assembly and operating conditions, it is not possible to determine the service life of a linear guide exactly in advance. The surest way to obtain an accurate estimate of the service life is still a comparison with similar assembly cases.



Linear guide rail type LFS-8-1 / LFS-8-2



Linear guide rails

- W 30 x H 20 mm (LFS-8-1)
W 30 x H 32.5 mm (LFS-8-2)
- 2 precision steel shafts Ø 8 mm
- twist-proof
- Aluminum shaft mounting profile, natural anodized
- Fastening from below by using M6 threaded rails in the T-slot indentation
- Conditionally self-supporting
- Special lengths offered upon request
- Weights: approx. 1.6 kg/m (LFS-8-1)
approx. 2.0 kg/m (LFS-8-2)

Options:

- Stainless construction
- Equipped with through-holes for M6 (this applies only to the type LFS-8-1)

Carriage

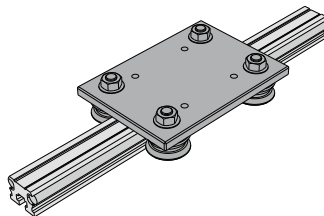

LW 6

- L 125 x W 90 x H 7.7 mm
 - Ground steel plate
 - 4 rollers Ø 31 mm, lubricated over the entire service life
 - Clearance-free adjustment possible
 - Weight: approx. 1 kg
- Part No.: 223011

Slide made of aluminum

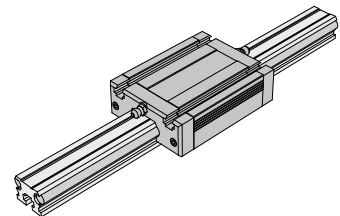

- Equipped with a recirculating ball guide
- Milled clamping surface
- T-slot inserts M6
- Central lubrication option
- Clearance-free adjustment possible

Option:

- Stainless construction

WS 1/70

- L 96 x W 72 x H 28.5 mm
 - Weight: approx. 0.4 kg
- Part No.: 2231000070
stainless: 223101 0070

WS 1

- L 126 x W 72 x H 28.5 mm
 - Weight: approx. 0.5 kg
- Part No.: 223100
stainless: 223101

Order key

	23500X	XXXX	
LFS-8-1 / standard	= 0	Length LFS-8-1	Length LFS-8-2
LFS-8-1 / stainless	= 1	in mm (inside a grid of 100mm)	in mm (inside a grid of 100mm)
LFS-8-2 / standard	= 2	for example 0029 = L 298	for example 0298 = L 298
LFS-8-2 / stainless	= 3	0299 = L 2998	2998 = L 2998

Steel shaft length: Total length L - 3 mm

Profile up to a length of 6000 mm available without butt joint, with divided steel shafts.

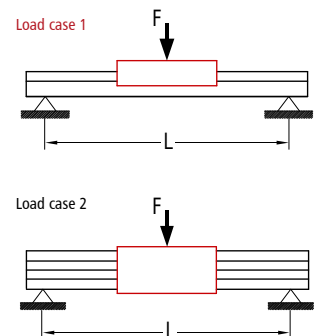
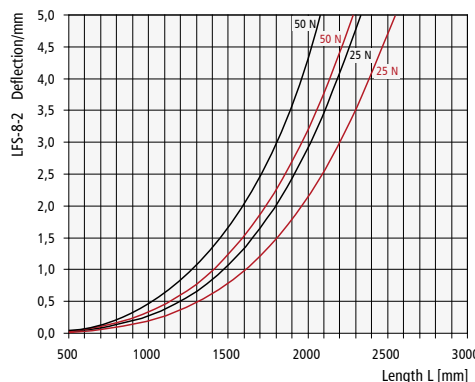
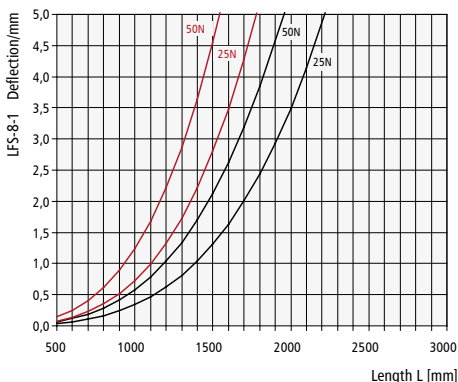



Dimensional drawing

LFS-8-1 and/or LFS-8-2 with aluminum slide type WS 1/70 or WS 1

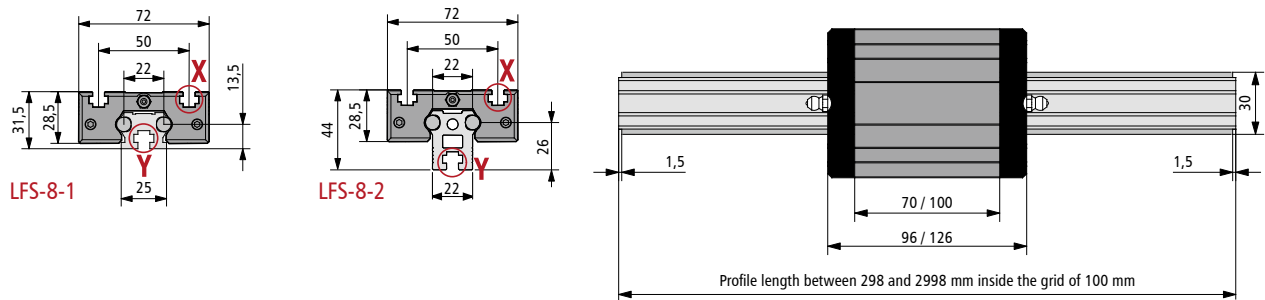

LFS-8-1 or LFS-8-2 with carriage type LW 6

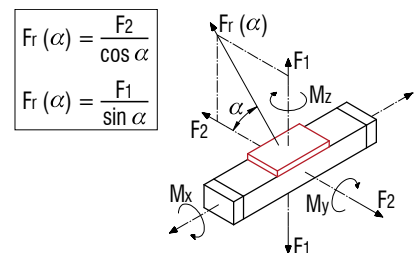
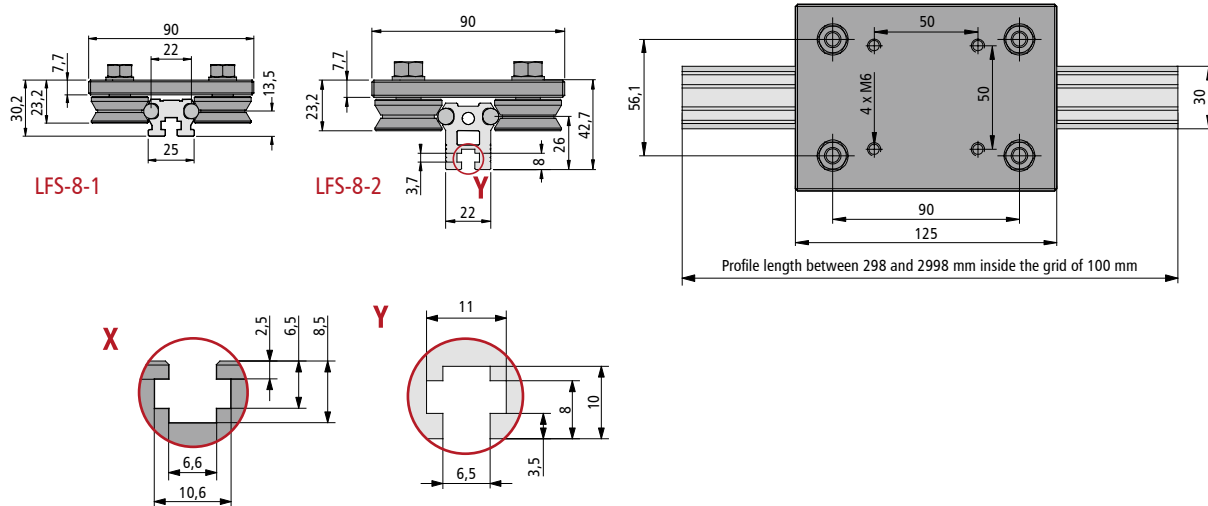

Load data

Aluminum slide type WS 1/70

C ₀	3114 N
C	1846 N
F ₁ static	2659 N
F ₁ dynamic	1576 N
F ₂ static	3114 N
F ₂ dynamic	1846 N
M _x static	37.3 Nm
M _y static	100.5 Nm
M _z static	117.6 Nm
M _x dynamic	22.1 Nm
M _y dynamic	59.5 Nm
M _z dynamic	69.7 Nm

Aluminum slide type WS 1

C ₀	4590 N
C	2390 N
F ₁ static	3920 N
F ₁ dynamic	2041 N
F ₂ static	4590 N
F ₂ dynamic	2390 N
M _x static	55.0 Nm
M _y static	148.1 Nm
M _z static	173.4 Nm
M _x dynamic	28.6 Nm
M _y dynamic	77.1 Nm
M _z dynamic	90.2 Nm

Carriage type LW 6

C ₀	2160 N
C	4000 N
F ₁ static	4320 N
F ₁ dynamic	3792 N
F ₂ static	2160 N
F ₂ dynamic	4000 N
M _x static	121.1 Nm
M _y static	194.4 Nm
M _z static	97.2 Nm
M _x dynamic	106.3 Nm
M _y dynamic	170.6 Nm
M _z dynamic	180.0 Nm



Linear guide rail type LFS-8-3

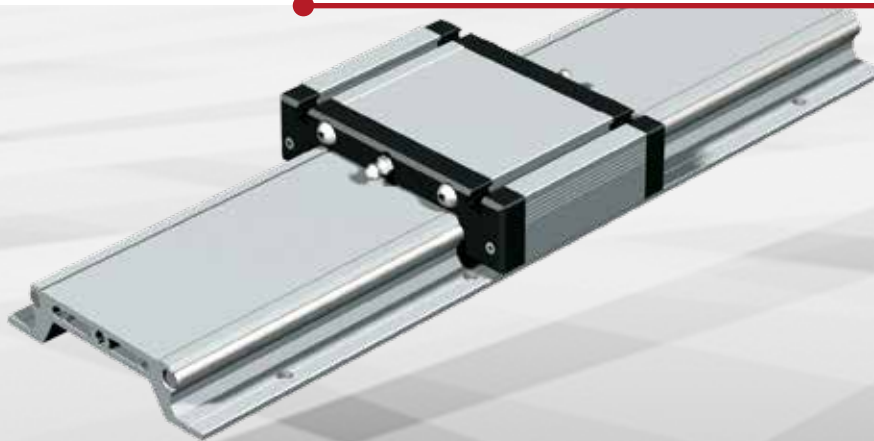

Linear guide rail

- W 115 x H 25.5 mm
- 2 precision steel shafts Ø 8 mm
- Particularly twist-proof
- Aluminum shaft mounting profile, natural anodized
- Fastening from above by using through-holes for M6 inside a grid of 100 mm
- Conditionally self-supporting
- Special lengths offered upon request
- Weight: approx. 3.2 kg/m
- Option: stainless construction

Carriage

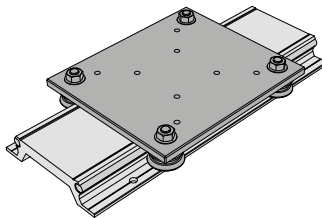

LW 7

- L 175 x W 150 x H 7.5 mm
 - Ground steel plate
 - 4 rollers Ø 31, lubricated over the entire service life
 - Clearance-free adjustment possible
 - Weight: approx. 2 kg
- Part No.: **223012**

Slide made of aluminum

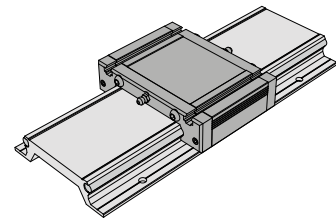

- Equipped with a recirculating ball guide
- Milled clamping surface
- T-slot inserts M6
- Central lubrication option
- Clearance-free adjustment possible

Option:

- Stainless construction

Order key

LFS-8-3 / Standard = 4 ^{23500X} ^{XXXX} Length LFS-8-3 for example 0029 = L 298
 LFS-8-3 / stainless = 5 in mm (inside a grid of 100 mm) 0299 = L 2998

Steel shaft length: Total length L - 1 mm
 Profile up to a length of 6000 mm available without butt joint, with divided steel shafts.

WS 3/70

- L 96 x W 130 x H 32 mm
 - Weight: approx. 0.5 kg
- Part No.: **223103 0070**
 stainless: **223103 1070**

WS 3

- L 176 x W 130 x H 32 mm
 - Weight: approx. 0.9 kg
- Part No.: **223103**
 stainless: **223103 1000**

Deflection

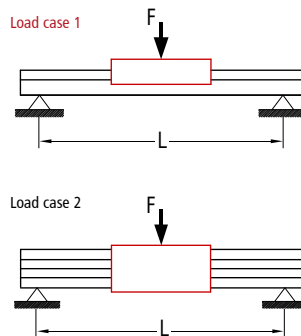
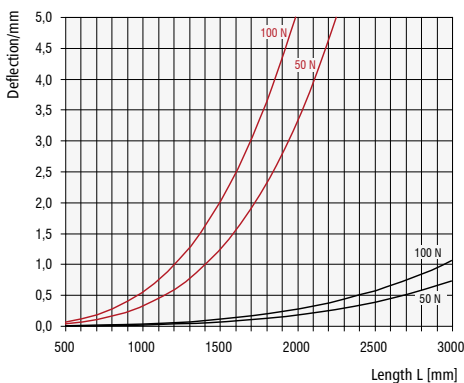



Dimensional drawing

LFS-8-3 with aluminum slide type WS3/70 and/or WS3

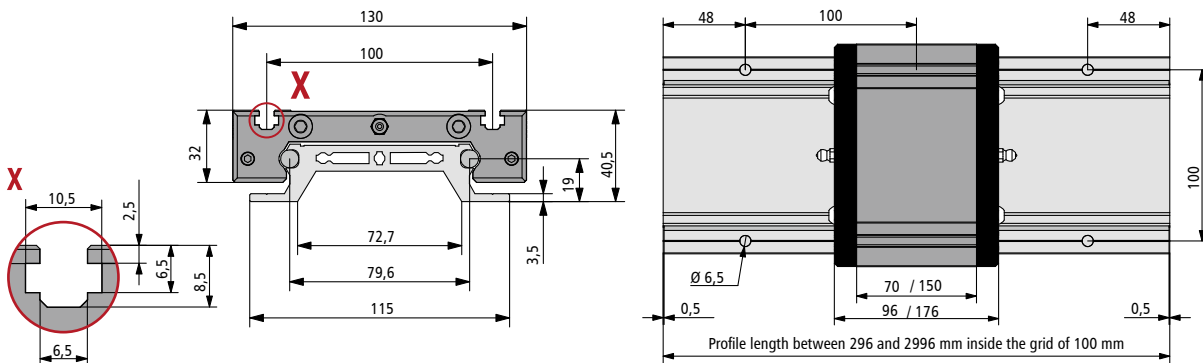

LFS-8-3 with carriage type LW7

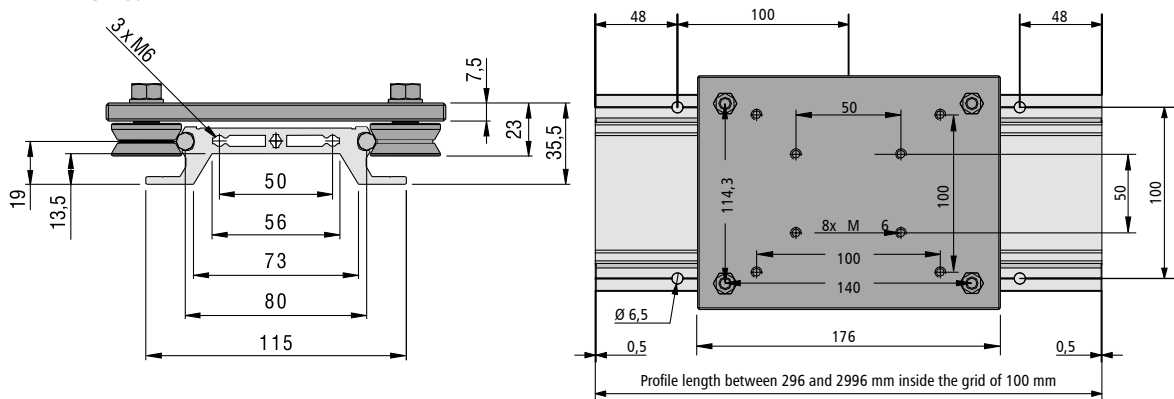

$$Fr(\alpha) = \frac{F_2}{\cos \alpha}$$

$$Fr(\alpha) = \frac{F_1}{\sin \alpha}$$

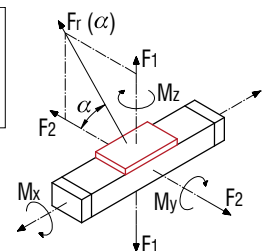

Load data

Aluminum slide type WS 3/70

C ₀	3141 N
C	1879 N
F ₁ static	2682 N
F ₁ dynamic	1604 N
F ₂ static	3141 N
F ₂ dynamic	1879 N
M _x static	115.7 Nm
M _y static	105.3 Nm
M _z static	123.3 Nm
M _x dynamic	69.2 Nm
M _y dynamic	62.9 Nm
M _z dynamic	73.7 Nm

Aluminum slide type WS 3

C ₀	6945 N
C	3190 N
F ₁ static	5931 N
F ₁ dynamic	2724 N
F ₂ static	6945 N
F ₂ dynamic	3190 N
M _x static	255.9 Nm
M _y static	232.8 Nm
M _z static	272.5 Nm
M _x dynamic	117.5 Nm
M _y dynamic	106.9 Nm
M _z dynamic	125.1 Nm

Carriage type LW 7

C ₀	2160 N
C	4000 N
F ₁ static	4320 N
F ₁ dynamic	3792 N
F ₂ static	2160 N
F ₂ dynamic	4000 N
M _x static	246.8 Nm
M _y static	302.4 Nm
M _z static	151.2 Nm
M _x dynamic	216.7 Nm
M _y dynamic	265.4 Nm
M _z dynamic	280.0 Nm



Linear guide rail type LFS-8-4



Illustration:
LFS-8-4 equipped with
2 steel shafts and an
aluminum slide

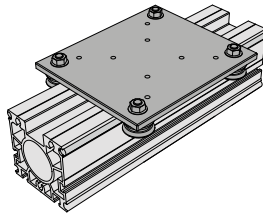

Illustration:
LFS-8-4 equipped with 4 steel shafts
and two aluminum slides (optional)

Linear guide rail

- W 80 x H 80 mm
- 4 precision steel shafts Ø 8 mm
- twist-proof
- Aluminum shaft mounting profile, natural anodized
- Fastening from below by using M6 threaded rails in the T-slot inserts or at the top by using M8 bores
- Lateral T-grooves for the fastening of the limit switch
- Conditionally self-supporting
- Special lengths offered upon request
- Weight: approx. 7.2 kg/m
- Options: stainless construction equipped with 2 steel shafts 2. slide and/or carriage

Carriage



LW 7

- L 175 x W 150 x H 7.5 mm
 - Ground steel plate
 - 4 rollers Ø 31 mm, lubricated over the entire service life
 - Clearance-free adjustment possible
 - Weight: approx. 2 kg
- Part No.: **223012**

Slide made of aluminum

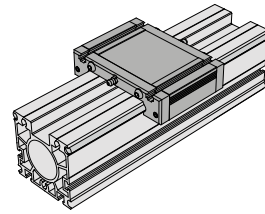

- Milled clamping surface
- T-slot inserts M6
- Central lubrication option
- Clearance-free adjustment possible

Option:

- Stainless construction

WS 3/70

- L 96 x W 130 x H 32 mm
 - Weight: approx. 0.5 kg
- Part No.: **223103 0070**
stainless: **223103 1070**

WS 3

- L 176 x W 130 x H 32 mm
 - Weight: approx. 0.9 kg
- Part No.: **223103**
stainless: **223103 1000**

Order key

23500X XXXX
LFS-8-4 / Standard = 6 Length LFS-8-4 for example 0029 = L 298
LFS-8-4 / stainless = 7 in mm (inside the grid of 100mm) 0299 = L 2998

Steel shaft length: total length L -3mm

Profile available up to a length of 6,000 mm without a butt joint, divided steel shafts.

Deflection

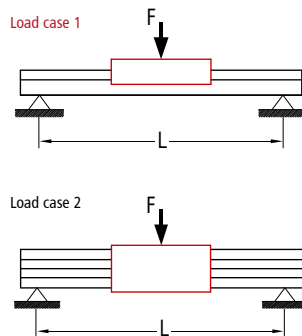
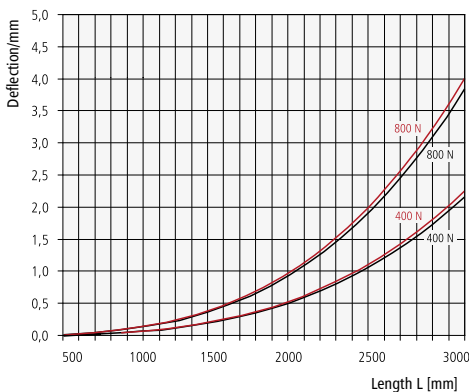



Dimensional drawing

LFS-8-4 with aluminum slide type WS3/70 and/or WS3

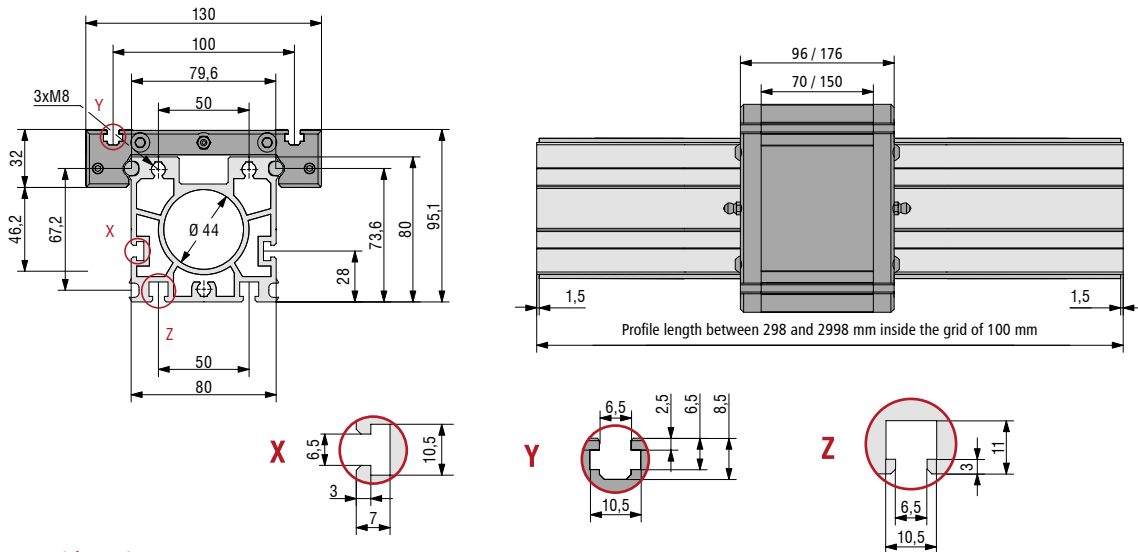

LFS-8-4 with carriage type LW7

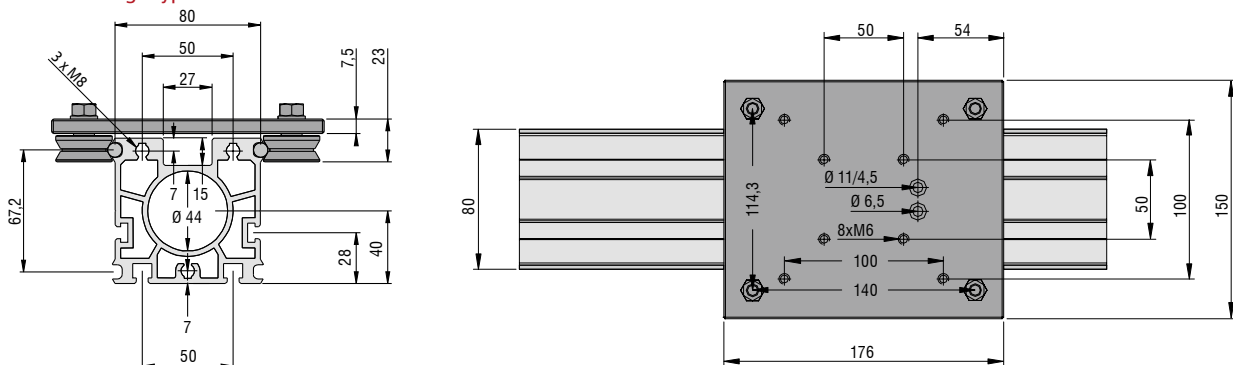

$$Fr(\alpha) = \frac{F_2}{\cos \alpha}$$

$$Fr(\alpha) = \frac{F_1}{\sin \alpha}$$

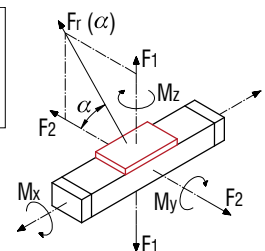

Load data

Aluminum slide type WS 3/70

C ₀	3141 N
C	1879 N
F ₁ static	2682 N
F ₁ dynamic	1604 N
F ₂ static	3141 N
F ₂ dynamic	1879 N
M _x static	115.7 Nm
M _y static	105.3 Nm
M _z static	123.3 Nm
M _x dynamic	69.2 Nm
M _y dynamic	62.9 Nm
M _z dynamic	73.7 Nm

Aluminum slide type WS 3

C ₀	6945 N
C	3190 N
F ₁ static	5931 N
F ₁ dynamic	2724 N
F ₂ static	6945 N
F ₂ dynamic	3190 N
M _x static	255.9 Nm
M _y static	232.8 Nm
M _z static	272.5 Nm
M _x dynamic	117.5 Nm
M _y dynamic	106.9 Nm
M _z dynamic	125.1 Nm

Carriage type LW 7

C ₀	2160 N
C	4000 N
F ₁ static	4320 N
F ₁ dynamic	3792 N
F ₂ static	2160 N
F ₂ dynamic	4000 N
M _x static	246.8 Nm
M _y static	302.4 Nm
M _z static	151.2 Nm
M _x dynamic	216.7 Nm
M _y dynamic	265.4 Nm
M _z dynamic	280.0 Nm



Linear guide rail type LFS-8-7

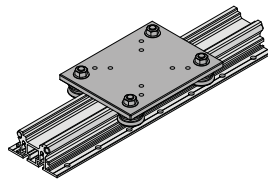

Illustration:
Linear guide rails and
Linear guide carriage

Linear guide rail

- W 78 x H 36 mm
- 2 precision steel shafts Ø 8 mm
mounting grid 100 mm
- shaft housing contour
(terminal connection)
- aluminium profile rail with T-slots,
natural anodized
- conditionally cantilevered
- Standard lengths in 100 mm
increments up to 3 m
- Special lengths offered upon request
- Weight: 2,9 kg/m

Carriage



LW 10

- L 150 x W 115 x H 7,7 mm
- Grounded steel plate
- 4 castors Ø 31 mm
- Lubricated for life
- Adjustable for no play
- Weight: 1.47 kg
- Part no.: **223 014**

Slide made of aluminum

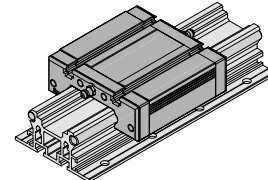

WS 11/70

- with 8 steel inserts
L 96 x W 96 x H 32 mm
- 4 ball circuits, adjustable for
no play
- Grease nipple frontally
- Weight: 0.40 kg
- Part no.: **223111 0070**

Ordering key

235 012 XXXX

Length LFS-8-7
in mm (inside the grid of 100mm)

for example **0019** = L 196
0299 = L 2996

Deflection

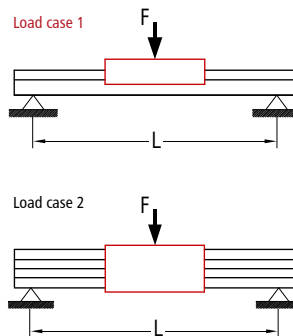
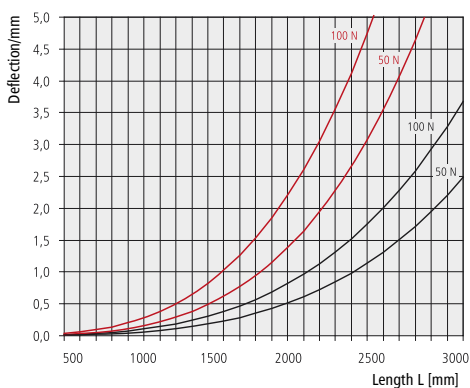

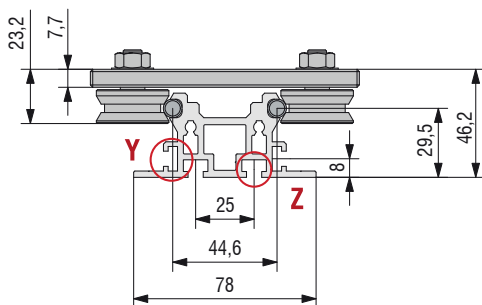
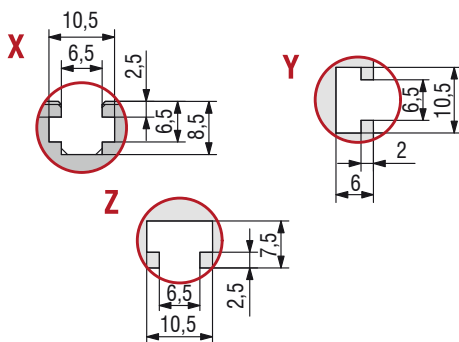
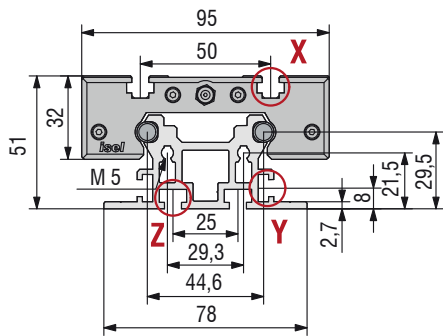

LFS-8-7 with aluminum slide type WS11/70

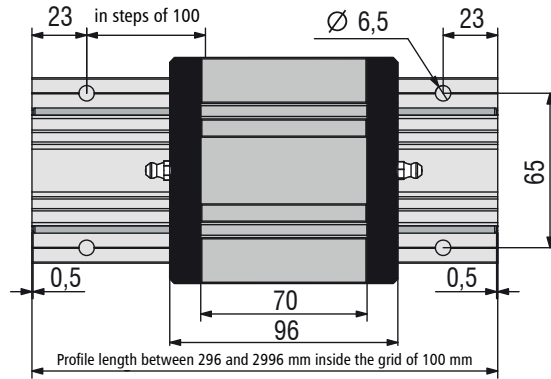

LFS-8-7 with carriage type LW10

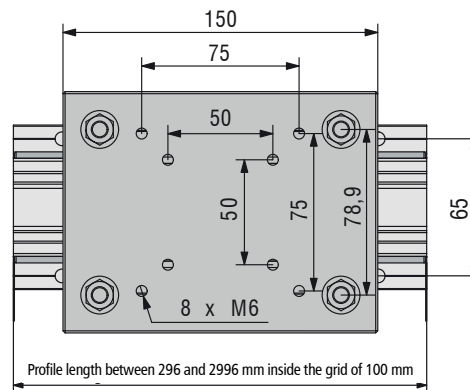

Load data

$$F_r(\alpha) = \frac{F_2}{\cos \alpha}$$

$$F_r(\alpha) = \frac{F_1}{\sin \alpha}$$

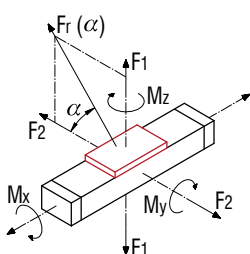

Carriage type LW 10

C ₀	2160 N
C	4000 N
F ₁ static	4320 N
F ₁ dynamic	3792 N
F ₂ static	2160 N
F ₂ dynamic	4000 N
M _x static	170,4 Nm
M _y static	248,4 Nm
M _z static	124,2 Nm
M _x dynamic	149,5 Nm
M _y dynamic	218,0 Nm
M _z dynamic	230,0 Nm

Aluminum slide type WS 11/70

C ₀	3114 N
C	1846 N
F ₁ static	2659 N
F ₁ dynamic	1576 N
F ₂ static	3114 N
F ₂ dynamic	1846 N
M _x static	67,3 Nm
M _y static	100,5 Nm
M _z static	117,6 Nm
M _x dynamic	39,9 Nm
M _y dynamic	59,5 Nm
M _z dynamic	69,7 Nm



Linear guide rail type LFS-12-1



Shaft mounting blocks

- Ø40 mm, hole distance 28 mm
 - Zinc cast, VE 10 pieces
- Part No.: 221501

Linear guide rail

- W 40 x H 27 mm
- Precision steel shafts Ø 12 mm
- twist-proof
- Aluminum shaft mounting blocks
- Attachment from above by using through-holes for M6 in the mounting blocks
- Any guide length up to 3 m
- Special lengths offered upon request
- Weight: approx. 1.9 kg/m

Carriage

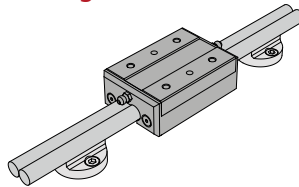

LW 3

- L 125 x W 85 x H 7.7 mm
 - Ground steel plate
 - Weight: approx. 0.93 kg
- Part No.: 223008

Steel slide

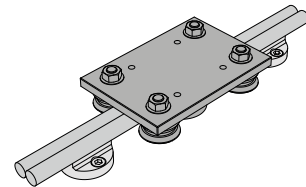

LS 1

- L 91 x W 60 x H 32 mm
 - Ground clamping surface
 - Weight: approx. 0.8 kg
- Part No.: 223006

Order key

227312 XXXX

for example 0298 = L 298

2998 = L 2,998

Length in mm (in a grid of 100mm)

Non-standard lengths are available upon request!

The part no. exclusively refers to one steel shaft.

Shaft receiving block

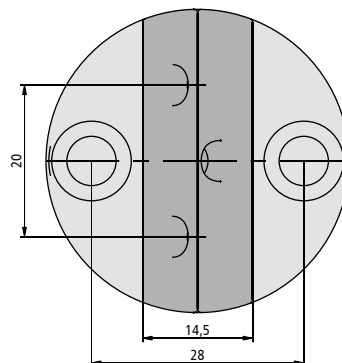
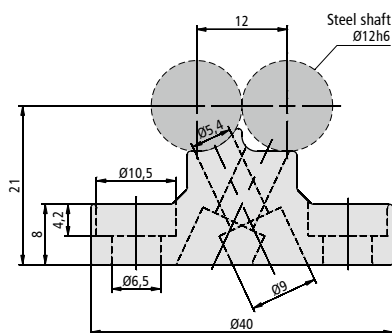



Dimensional drawing

2 x LFS-12-1 equipped with carriage LW 3 with shaft mounting blocks

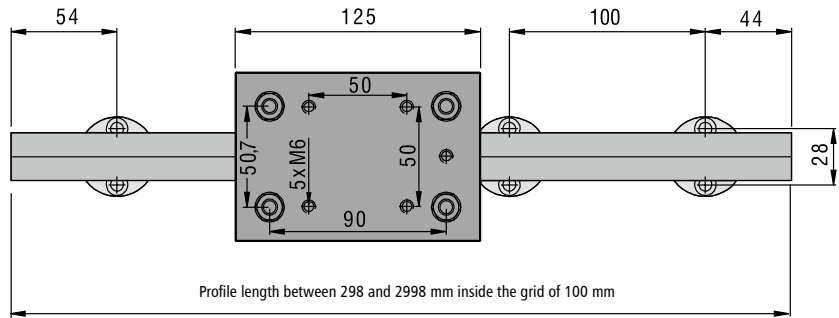
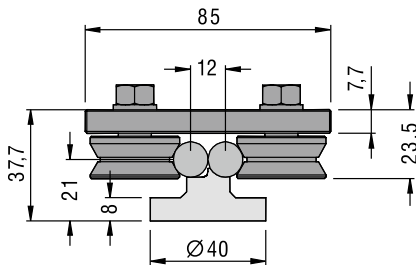

2 x LFS-12-1 equipped with a steel slide LS 1 equipped with shaft mounting blocks

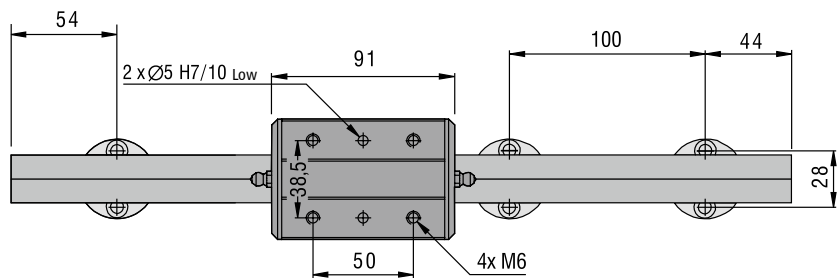
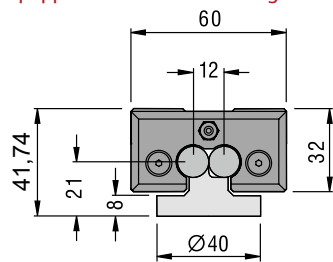

Load data

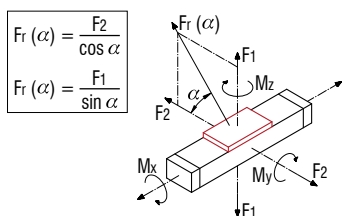

Carriage type LW 3

C ₀	2160 N
C	4000 N
F ₁ static	4320 N
F ₁ dynamic	3846 N
F ₂ static	2160 N
F ₂ dynamic	4000 N
M _x static	109.5 Nm
M _y static	194.4 Nm
M _z static	97.2 Nm
M _x dynamic	97.4 Nm
M _y dynamic	173.0 Nm
M _z dynamic	180.0 Nm

Steel slide type LS 1

C ₀	3508 N
C	2105 N
F ₁ static	3549 N
F ₁ dynamic	2130 N
F ₂ static	3508 N
F ₂ dynamic	2105 N
M _x static	36.2 Nm
M _y static	129.0 Nm
M _z static	127.5 Nm
M _x dynamic	21.7 Nm
M _y dynamic	77.4 Nm
M _z dynamic	76.5 Nm



Linear guide rail type LFS-12-11



Linear guide rail

- W 20 x H 31 mm
- Precision steel shaft \varnothing 12 mm
- Aluminum shaft mounting profile, natural anodized
- Fastening from below by using M6 threaded rails in the T-slot insert on a flat surface
- Special lengths offered upon request
- Weight: approx. 1.3 kg/m

Carriage

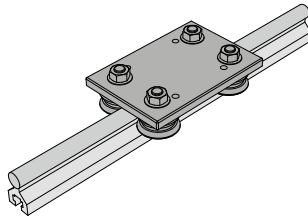

LW 5

- L 110 x W 75 x H 7.7 mm
 - Ground steel plate
 - 4 rollers \varnothing 31 mm, lubricated over the entire service life
 - Clearance-free adjustment possible
 - Weight: 0.81 kg
- Part No.: **223010**

Slide made of aluminum

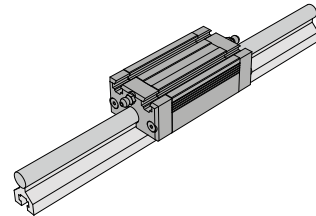

- Equipped with a recirculating ball guide
- T-slot inserts M6
- Central lubrication option
- Clearance-free adjustment possible

Option:

- Stainless construction

WS 6/70

- L 96 x W 50 x H 31.5 mm
 - Weight: approx. 0.3 kg
- Part No.: **223106 0070**
Stainless: **223106 1070**

WS 6

- L 126 x W 50 x H 31.5 mm
 - Weight: approx. 0.5 kg
- Part No.: **223106**
Stainless: **223106 1000**

Order key

Length LFS-12-11 in mm (in the grid of 100mm) **220002** ~~XXXX~~
for example **0029** = L 298
0299 = L 2998

Profile length = total length L - 2 mm

Deflection

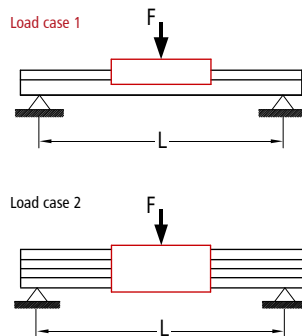
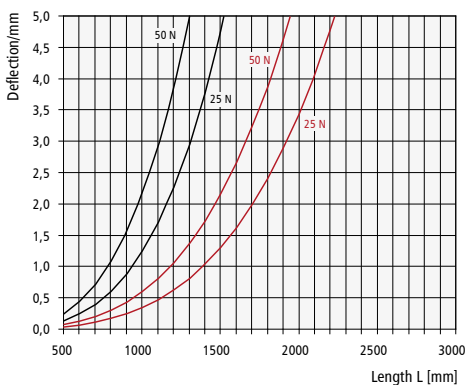



Dimensional drawing

LFS-12-11 equipped with carriage type LW 5

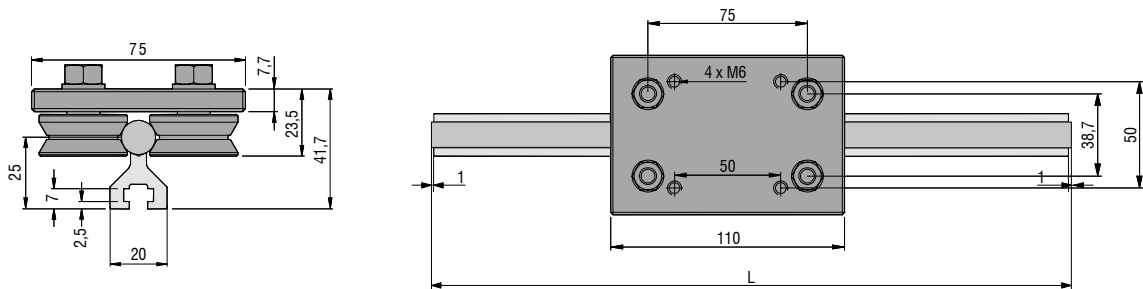

LFS-12-11 equipped with aluminum slide type WS 6/70 and/or WS 6

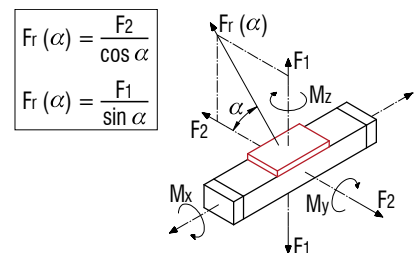
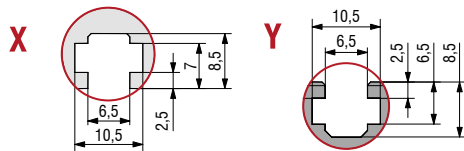
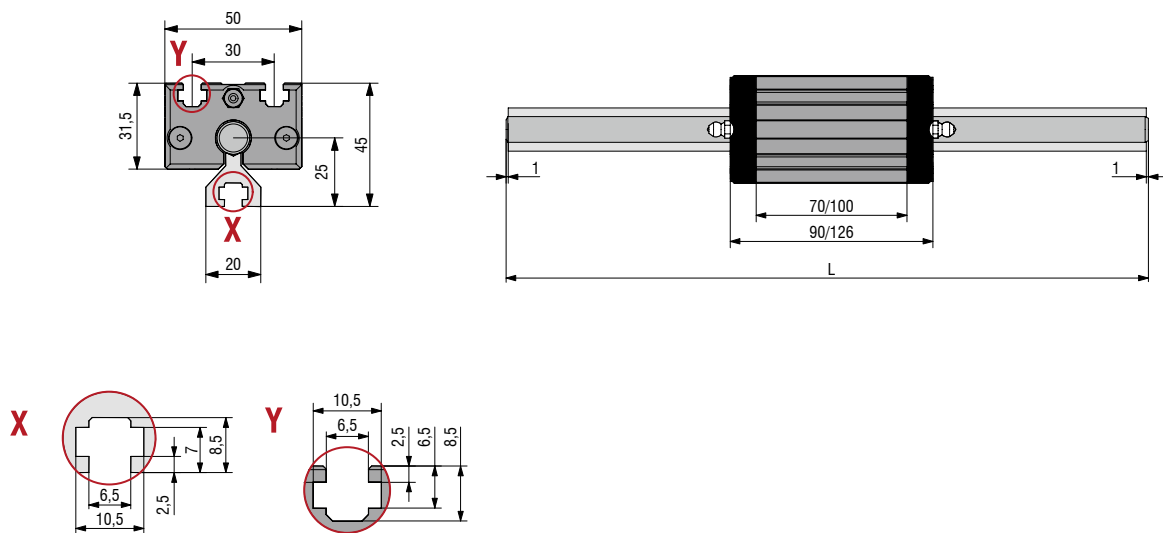

Load data

Carriage type LW 5

C ₀	2160 N
C	4000 N
F ₁ static	4320 N
F ₁ dynamic	3846 N
F ₂ static	2160 N
F ₂ dynamic	4000 N
M _x static	-
M _y static	162.0 Nm
M _z static	81.0 Nm
M _x dynamic	-
M _y dynamic	144.2 Nm
M _z dynamic	150.0 Nm

Aluminum slide type WS 6/70

C ₀	3303 N
C	1873 N
F ₁ static	2821 N
F ₁ dynamic	1599 N
F ₂ static	3303 N
F ₂ dynamic	1873 N
M _x static	-
M _y static	105.3 Nm
M _z static	123.3 Nm
M _x dynamic	-
M _y dynamic	59.7 Nm
M _z dynamic	69.9 Nm

Aluminum slide type WS 6

C ₀	4868 N
C	2426 N
F ₁ static	4157 N
F ₁ dynamic	2071 N
F ₂ static	4868 N
F ₂ dynamic	2426 N
M _x static	-
M _y static	155.2 Nm
M _z static	181.7 Nm
M _x dynamic	-
M _y dynamic	77.3 Nm
M _z dynamic	90.5 Nm



Linear guide rail type LFS-12-2



Linear guide rail

- W 62 x H 31 mm
- 2 precision steel shafts Ø 12 mm
- twist-proof
- Aluminum shaft mounting profile, natural anodized
- High degree of parallelism thanks to the patented shaft mounting contour
- High guiding accuracy
- Fastening from above or from below by using Ø 6.5 holes inside the grid of 100 mm a flat surface
- Lengths in the grid of 100 mm
- Max. length up to 2998 mm
- Special lengths offered upon request
- Weight: approx. 3.3 kg/m

Carriage

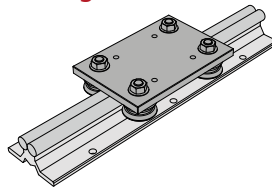

LW 3

- L 125 x W 85 x H 7.7 mm
 - Ground steel plate
 - Weight: approx. 0.93 kg
- Part No.: 223008

Steel slide

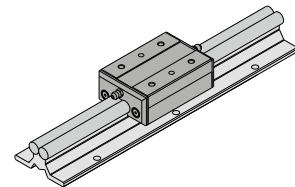

LS 1

- L 91 x W 60 x H 32 mm
 - Ground clamping surface
 - Weight: approx. 0.8 kg
- Part No.: 223006

Order key

235200 XXXX

for example 0298 = L 298

2998 = L 2,998

Length in mm (in a grid of 100mm)

Profile length = total length L - 2 mm

Deflection

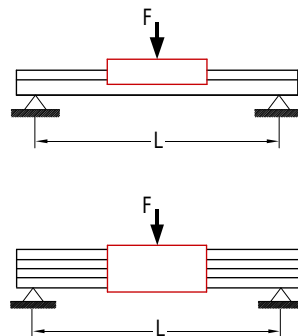
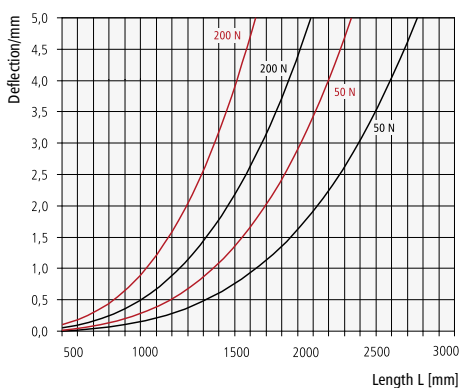



Dimensional drawing

LFS-12-2 equipped with a carriage type LW 3

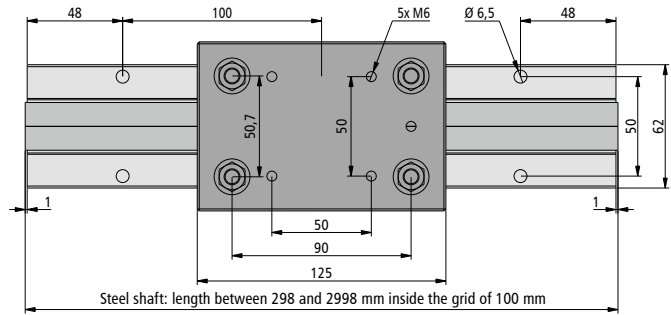
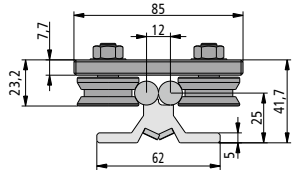

LFS-12-2 equipped with a steel slide type LS 1

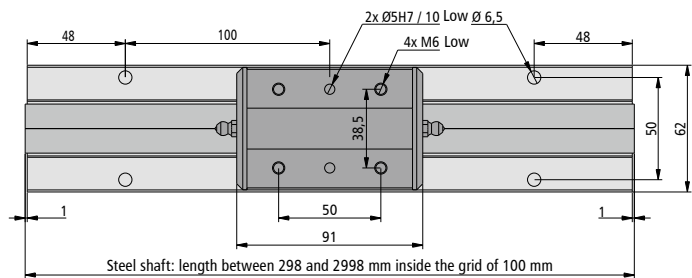
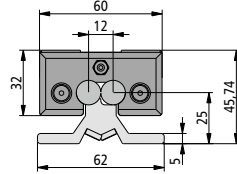

Load data

$$F_r(\alpha) = \frac{F_2}{\cos \alpha}$$

$$F_r(\alpha) = \frac{F_1}{\sin \alpha}$$

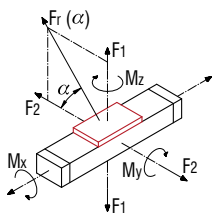

Carriage type LW 3

C ₀	2160 N
C	4000 N
F ₁ static	4320 N
F ₁ dynamic	3846 N
F ₂ static	2160 N
F ₂ dynamic	4000 N
M _x static	109.5 Nm
M _y static	194.4 Nm
M _z static	97.2 Nm
M _x dynamic	97.4 Nm
M _y dynamic	173.0 Nm
M _z dynamic	180.0 Nm

Steel slide type LS 1

C ₀	3508 N
C	2105 N
F ₁ static	3549 N
F ₁ dynamic	2130 N
F ₂ static	3508 N
F ₂ dynamic	2105 N
M _x static	36.2 Nm
M _y static	129.0 Nm
M _z static	127.5 Nm
M _x dynamic	21.7 Nm
M _y dynamic	77.4 Nm
M _z dynamic	76.5 Nm



Linear guide rail type LFS-12-3



Linear guide rail

- W 90 x H 31 mm
- 2 precision steel shafts Ø 12 mm
- twist-proof
- Aluminum shaft mounting profile, natural anodized
- Increased shaft distance enabling the reception of higher moments
- Fastening from above or from below by using through-holes for M6 inside the grid of 100 mm
- Any guide length possible
- Weight: approx. 3.9 kg/m

Order key

235300 XXXX
 for example 0298 = L 298
 2998 = L 2,998

Length in mm (in a grid of 100mm)

Profile length = total length L - 2 mm
 Special lengths over 3000 mm equipped with rod connection upon request.

Carriage

- Clearance-free adjustment possible
- 4 rollers Ø 31 mm, lubricated over the entire service life

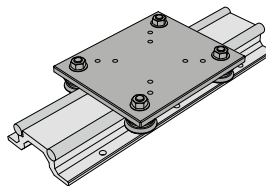

LW 8

- L 150 x W 125 x H 7.5 mm
 - Ground steel plate
 - Weight: 1.51 kg
- Part No.: 223013

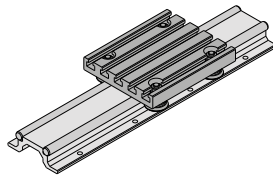

LW 2

- L 150 x W 125 x H 34.5 mm
 - Aluminum T-slot plate
 - Weight: 0.97 kg
- Part No.: 223005

Linear guide slide

- Ground steel plate
- Central lubrication option
- Clearance-free adjustment possible

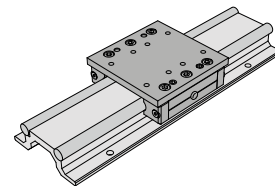

WS 7/70

- L 100 x W 100 x H 32 mm
 - Weight: approx. 0.8 kg
- Part No.: 223107 0070

WS 7

- L 200 x W 100 x H 32 mm
 - Weight: approx. 1.7 kg
- Part No.: 223107

Deflection

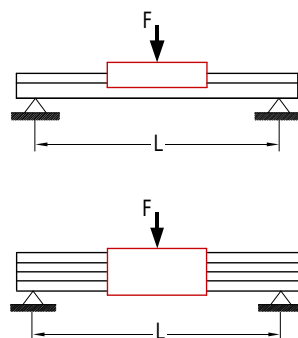
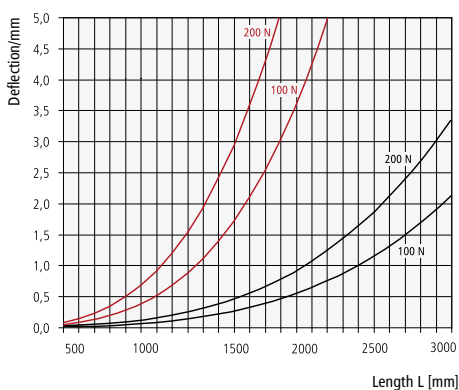



Dimensional drawing

LFS-12-3 equipped with carriage type LW 8

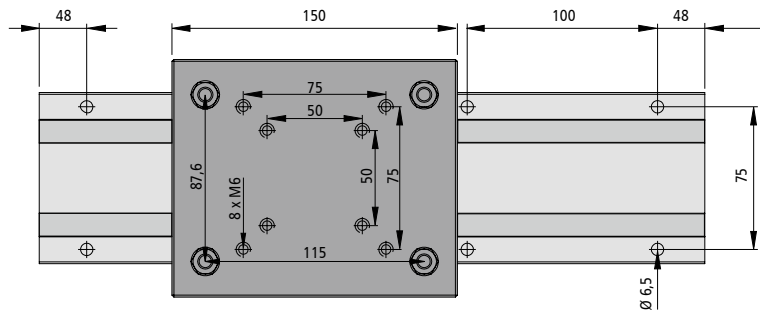
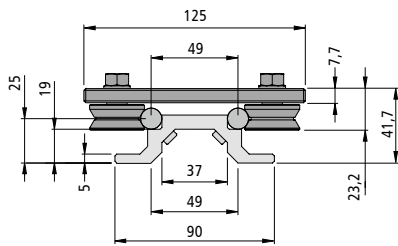

LFS-12-3 equipped with carriage type LW 2

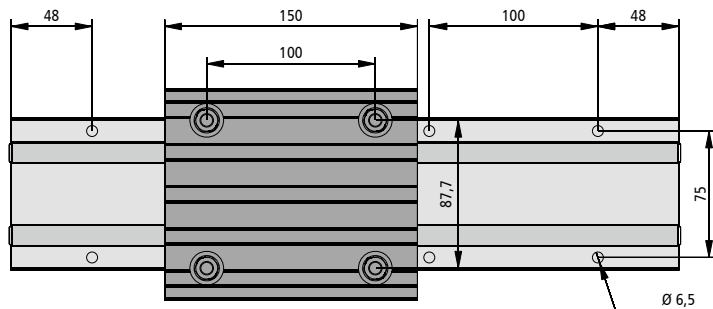
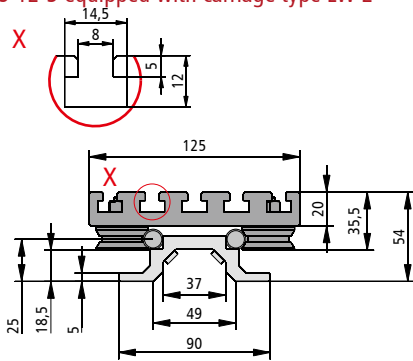

LFS-12-3 equipped with aluminum slide type WS 7

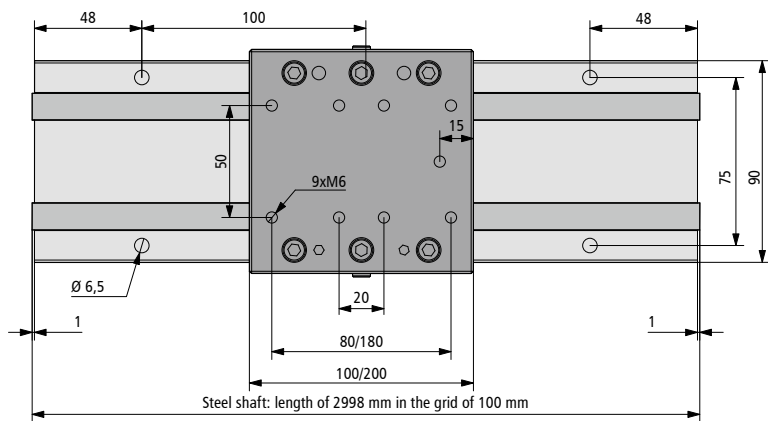
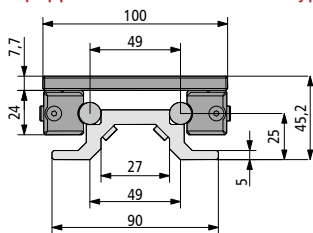

$$F_r(\alpha) = \frac{F_2}{\cos \alpha}$$

$$F_r(\alpha) = \frac{F_1}{\sin \alpha}$$

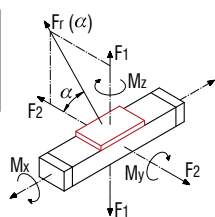

Load data

Carriage type LW 8		Carriage type LW 2		Linear guide slide type WS 7/70		Linear guide slide type WS 7	
C ₀	2160 N	C ₀	3114 N	C ₀	3303 N	C ₀	7303 N
C	4000 N	C	1846 N	C	1873 N	C	3179 N
F ₁ static	4320 N	F ₁ static	2659 N	F ₁ static	2821 N	F ₁ static	6237 N
F ₁ dynamic	3846 N	F ₁ dynamic	1576 N	F ₁ dynamic	1599 N	F ₁ dynamic	2715 N
F ₂ static	2160 N	F ₂ static	3114 N	F ₂ static	3303 N	F ₂ static	7303 N
F ₂ dynamic	4000 N	F ₂ dynamic	1846 N	F ₂ dynamic	1873 N	F ₂ dynamic	3179 N
M _x static	189.2 Nm	M _x static	216.0 Nm	M _x static	82.0 Nm	M _x static	181.2 Nm
M _y static	248.4 Nm	M _y static	100.5 Nm	M _y static	105.3 Nm	M _y static	232.8 Nm
M _z static	124.2 Nm	M _z static	108.0 Nm	M _z static	123.3 Nm	M _z static	272.5 Nm
M _x dynamic	168.4 Nm	M _x dynamic	168.4 Nm	M _x dynamic	46.4 Nm	M _x dynamic	78.8 Nm
M _y dynamic	221.1 Nm	M _y dynamic	192.3 Nm	M _y dynamic	59.7 Nm	M _y dynamic	101.3 Nm
M _z dynamic	230.0 Nm	M _z dynamic	200.0 Nm	M _z dynamic	69.9 Nm	M _z dynamic	118.6 Nm



Linear guide rail type LFS-12-10



Linear guide rail

- W 36 x H 24.5 mm
- 2 precision steel shafts Ø 12 mm
- twist-proof
- Aluminum shaft mounting profile, natural anodized
- Attachment from below by using M6 threaded rails in the T-groove and from above by through-holes for M6 inside a grid of 50 mm
- Conditionally self-supporting
- Special lengths offered upon request
- Weight: approx. 2.9 kg/m

Order key

220001 XXXX
 for example 0300 = L 296
 3000 = L 2996
 Length in mm (inside a grid of 100mm)

Profile length = total length L -4 mm
 Special lengths over 3000 mm equipped with rod connection upon request.

Deflection

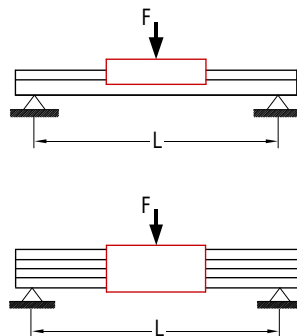
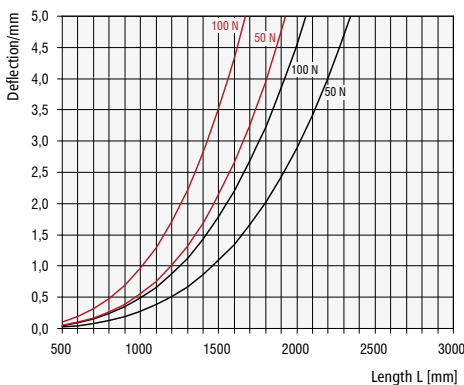

Linear guide slide

- Ground steel plate
- Lubrication option
- Clearance-free adjustment possible

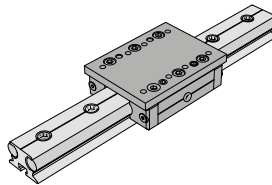

WS 8/70

- L 100 x W 75 x H 31.5 mm
- Weight: approx. 0.7 kg
- Part No.: 223108 0070

WS 8

- L 150 x W 75 x H 31.5 mm
- Weight: approx. 1.0 kg
- Part No.: 223108

Carriage

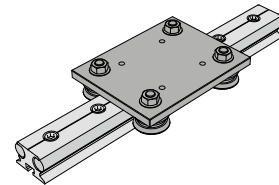

LW 4

- L 125 x W 97 x H 7.7 mm
- Ground steel plate
- 4 rollers Ø 31 mm, lubricated over the entire service life
- Clearance-free adjustment possible
- Weight: 1.02 kg
- Part No.: 223009

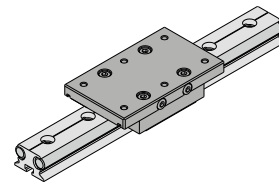

Double track set 1

- L 75 x W 75 x H 30.2 mm
- Equipped with 2 linear ball bearings SMALL
- Part No.: 223001

Double track set 2

- L 125 x W 75 x H 30.2 mm
- Equipped with 2 linear ball bearings LARGE
- Part No.: 223002



Dimensional drawing

LFS-12-10 equipped with slide type WS 8

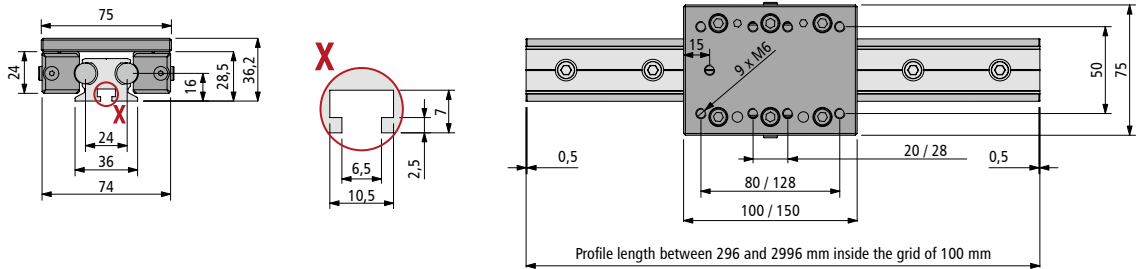

LFS-12-10 equipped with carriage type LW 4

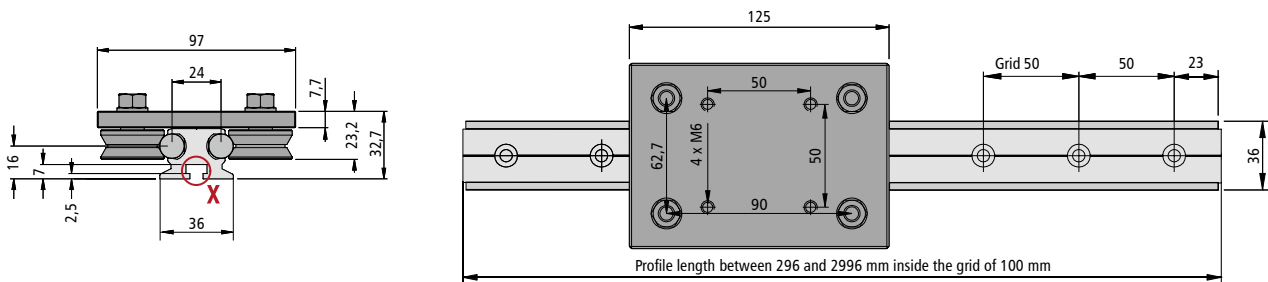

LFS-12-10 equipped with double track set

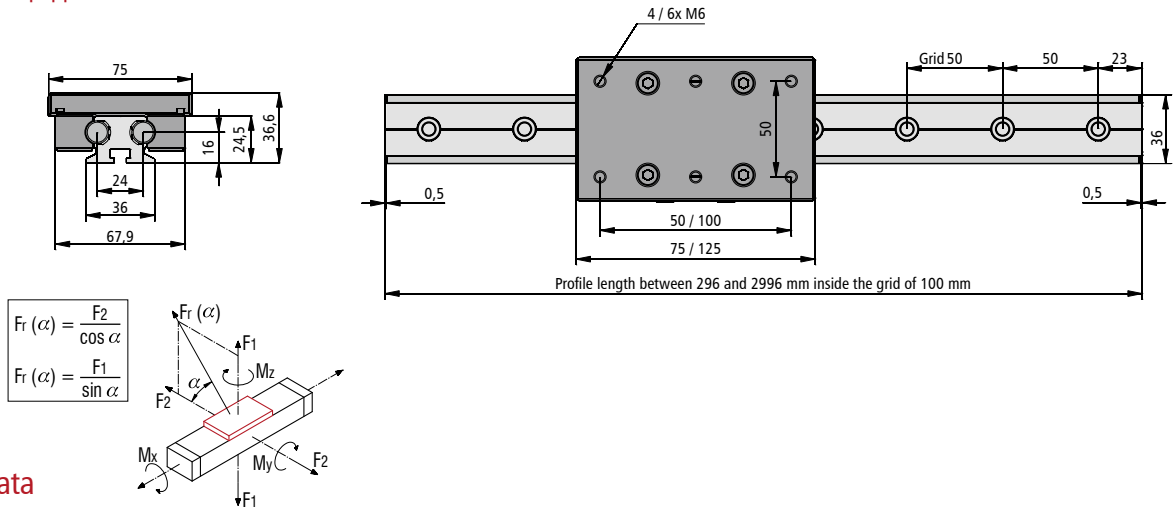

Load data

Linear guide slide type WS 8/70		Linear guide slide type WS 8		Carriage type LW 4		Double track set 1		2	
C ₀	3303 N	C ₀	4868 N	C ₀	2160 N	C ₀	645 N	1905 N	
C	1873 N	C	2426 N	C	4000 N	C	600 N	1125 N	
F ₁ static	2821 N	F ₁ stat.	4157 N	F ₁ stat.	4320 N	F ₁ stat.	652 N	1927 N	
F ₁ dynamic	1599 N	F ₁ dyn.	2071 N	F ₁ dyn.	3846 N	F ₁ dyn.	607 N	1138 N	
F ₂ static	3303 N	F ₂ stat.	4868 N	F ₂ stat.	2160 N	F ₂ stat.	645 N	1905 N	
F ₂ dynamic	1873 N	F ₂ dyn.	2426 N	F ₂ dyn.	4000 N	F ₂ dyn.	600 N	1125 N	
M _x static	46.7 Nm	M _x stat.	68.8 Nm	M _x stat.	135.4 Nm	M _x stat.	16.0 Nm	46.0 Nm	
M _y static	105.3 Nm	M _y stat.	155.2 Nm	M _y stat.	194.4 Nm	M _y stat.	13.0 Nm	119 Nm	
M _z static	123.3 Nm	M _z stat.	181.7 Nm	M _z stat.	97.2 Nm	M _z stat.	13.0 Nm	118 Nm	
M _x dynamic	26.4 Nm	M _x dyn.	34.2 Nm	M _x dyn.	120.5 Nm	M _x dyn.	15.0 Nm	27.0 Nm	
M _y dynamic	59.7 Nm	M _y dyn.	77.3 Nm	M _y dyn.	173.0 Nm	M _y dyn.	12.0 Nm	71.0 Nm	
M _z dynamic	69.9 Nm	M _z dyn.	90.5 Nm	M _z dyn.	180.0 Nm	M _z dyn.	12.0 Nm	70.0 Nm	



T-slot accessories

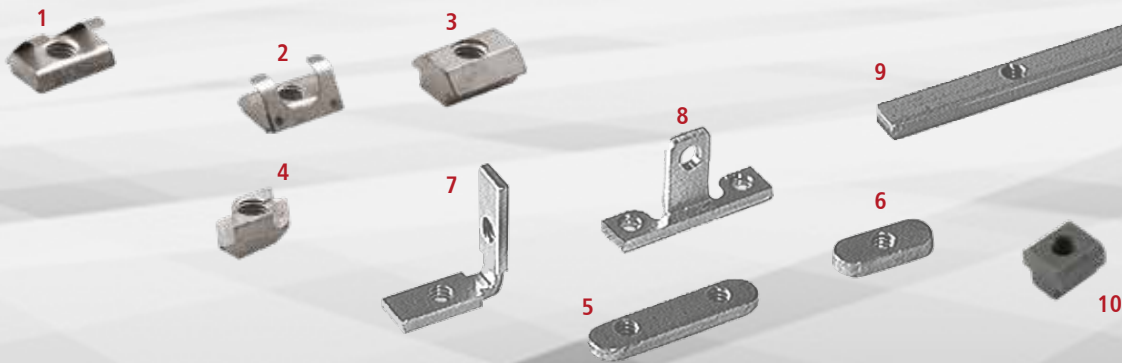

Sliding nuts M5

- galvanized
- PU 20 pieces
- for all T-slots except aluminum profiles: PT 25, PT 50, PS 200, RE 40 and RE 65 (with fastening only possible at the top)

Equipped with spring

Part No. M5: 209005 0002 (figure 2)

Part No. M6: 209005 0003 (figure 1)

with a large bevel

Part No. M6: 209005 0004 (figure 3)

in rhombus shape

Part No. M6: 209005 0006 (figure 4)

Threaded rail M6

- 10 x 4 mm
 - galvanized
 - M6 Ra 50 mm
 - PU 3 pieces per 1 m
- Part No.: 209011 (figure 9)

Sliding nut M6

- L 25 x W 10 x H 3.5
- galvanized
- PU 100 pieces
- For all T-slots except aluminum profiles: PT / RE 40, 65

Part No.: 209001 0005 (figure 6)

Sliding nut M6

- L 25 x W 13 x H 5
- galvanized
- PU 50 pieces
- for all T-slots: PT / RE 40, 65

Part No.: 209004 0001 (figure 6)

Sliding nut 2 x M6

- L 45 x W 10 x H 3.5
- galvanized
- PU 50 pieces
- For all T-slots except aluminum profiles: PT / RE 40, 65

Part No.: 209002 0004 (figure 5)

Sliding nut 2 x M6

- L 45 x W 13 x H 6
- galvanized
- 2 x M6 Ra 25 mm
- PU 25 pieces
- for all T-slots: PT / RE 40, 65

Part No.: 209005 0001 (figure 5)

Angle sliding nut 2 x M6

- galvanized
- PU 25 pieces
- For all T-slots except aluminum profiles: PT / RE 40, 65

Part No.: 209021 0003 (figure 7)

Special angular sliding nut 3 x M6

- galvanized, PU 25 pieces
- For all T-slots except aluminum profiles: PT / RE 40, 65

Part No.: 209022 0003 (figure 8)

T-nuts M6

- DIN 508
- Strength 10
- PU 20 pieces

Part No.: 209119 0003 (figure 10)

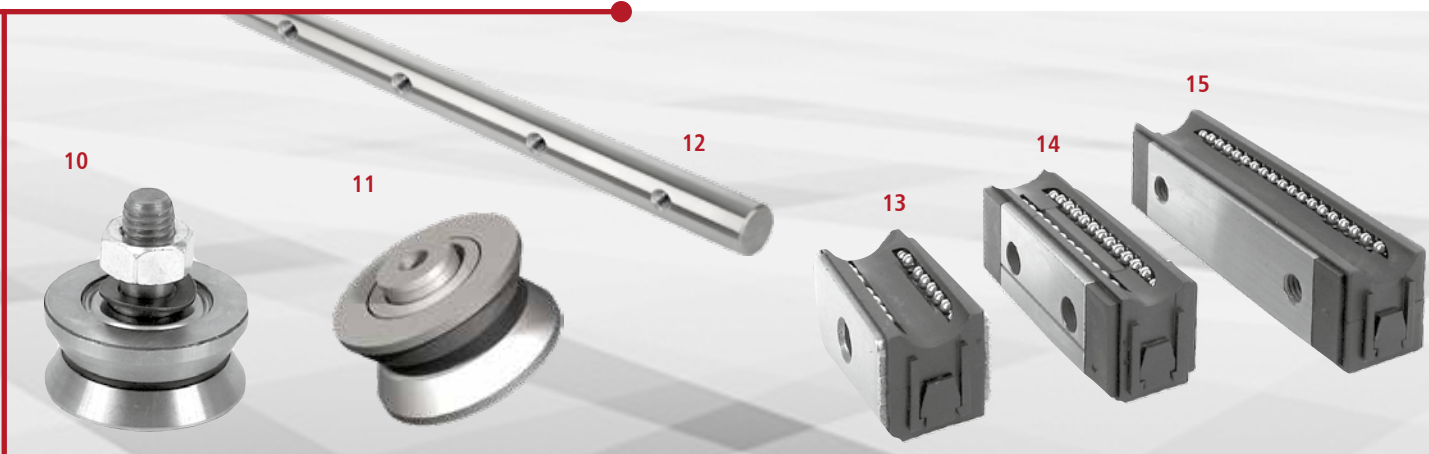

Roller Ø 21 mm

- concentric
- PU 2 pieces

Part No.: 222003 (figure 10)

- eccentric
- PU 2 pieces

Part No.: 222004 (without figure)

Roller Ø 31 mm

- concentric
- PU 2 pieces

Part No.: 222006 (without figure)

- eccentric
- PU 2 pieces

Part No.: 222007 (without figure)

Roller Ø 20 mm for SF 12

- with threaded hole M4
- PU 2 pieces

Part No.: 222010 (figure 11)

Guide shaft SF 12 / SF 16

- Precision steel shaft
Ø 12 and/or 16 mm, length 3 m
- Hardened and ground

Part No.: 220019 XXXX (figure 12)

(SF12, 3m, with blind hole M5 inside the grid of 100 mm)

Part No.: 220020 XXXX (without figure)

(SF12, 3m, with stepped bore for special screws M4 inside the grid of 100 mm)

Part No.: 220023 XXXX (without figure)

(SF16, 3m, with stepped bore for special screws M5 inside the grid of 50 mm)

Part No.: 220024 XXXX (without figure)

(SF16, 3m, with blind hole M6 in the grid of 100 mm)

Linear ball bearing (for steel shafts Ø 12 mm)

Linear ball bearing small

- L 40 x W 20 x H 19 mm
- PU 2 pieces

Part No.: 222001 (figure 13)

Linear ball bearing medium

- L 60 x W 20.5 x H 17.8 mm
- PU 2 pieces

Part No.: 222000 (figure 14)

Linear ball bearing large

- L 80 x W 20 x H 19 mm
- PU 2 pieces

Part No.: 222002 0001 (figure 15)

Universal grease

Part No.: 299031 (without figure)

Impact gun for grease

Part No.: 931170 (without figure)



Profile rail guide type PSF 15, 20, 25 and 30



Features

- High rigidity
- Excellent dynamic characteristics: $V_{max} > 10 \text{ m/s}$, $a_{max} > 450 \text{ m/s}^2$
- High static and dynamic moment loads possible
- the same load ratings for all load directions.
- The guide rails can be screwed on from above (screw head countersink) and from below (thread)
- special surface coatings are possible

Frame size	Lo [mm]	Hc [mm]
PSF 15	12.4	9.35
PSF 20	16.4	12.5
PSF 25	19.5	14.5
PSF 30	24.0	17.0

PSF – profile rail guide

The PSF linear guides are designed with four raceways in an O arrangement. The precision steel balls transmit forces introduced at a contact angle of 45 degrees (see the sketch here in the following). The O arrangement provides a high level of torsional rigidity.

In order to achieve an ideal level in terms of load ratings and rigidity, the greatest possible number of steel balls were used despite the limited space availability. This means that high static and dynamic moment loads are feasible. The same load ratings apply to all load directions with a compact design.

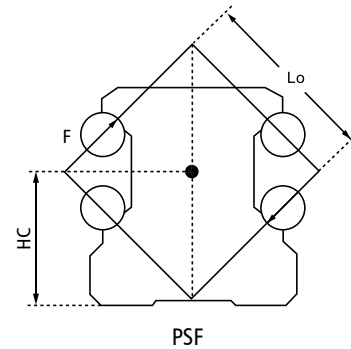

Ecological lubrication system (Eco-System):

The embedded lubrication reservoir supplies the rolling elements directly with the lubricant. This function allows the lubrication intervals to be extended in a considerable manner. The Eco-System is particularly effective for the short-stroke use.

More information concerning the designs, dimensions and ordering options can be found in the PSF linear guides catalogue as well as in the online shop on the website www.isel.com.

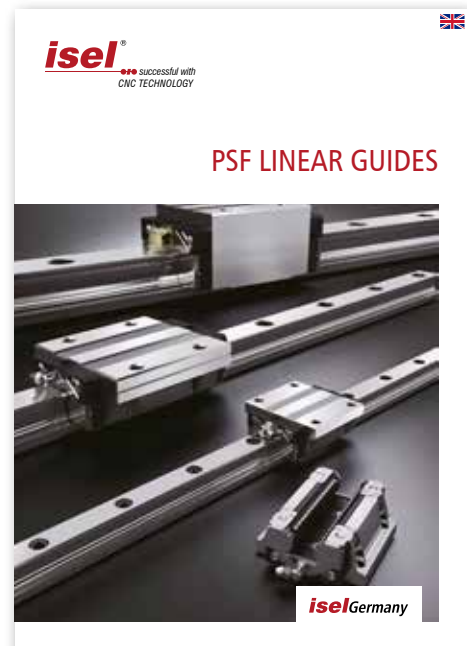



Manual clamping element

Note:

Can be used for ball guide rails.

Assembly note:

Operating temperature range between 0 and 70 °C

Pay attention to a rigid connection construction.



Dimensional drawing

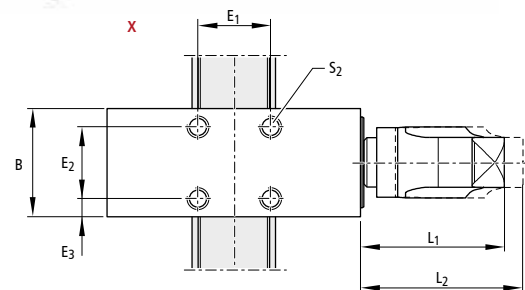
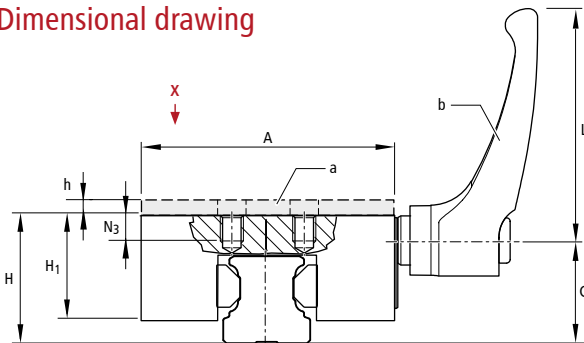

a) Spacer plate (accessories)

b) The position of the hand lever can be changed.

Size	Dimensions [mm]											Weight [kg]			
	A	B	C	E ₁	E ₂	E ₃	H ³⁾	H ₁	h	L	L ₁		L ₂ ²⁾	N ₃	S ₂
15	37	24	19.5	17	17	3.5	24	19	4	44	33	30	5	M4	0.1
20	60	24	24.5	15	15	4.5	28	23	2	44	33	30	6	M5	0.2
25	68	28	28	20	20	4	33	26	3 / 7	64	38	41	8	M6	0.28
30	70	39	34	22	22	8.5	42	33	3	64	38	41.5	8	M6	0.64

1) Test carried out with oily guide rail

2) Manual lever disengaged

3) Height compensation by means of a spacer plate (h) depending on the carriage height

Item designation	Size	Holding strength [N]	Tightening Torque [Nm]	Part No.
HKE 15	15	1,200	4	223509 0001
HKE 20	20	1200	5	223510 0001
HKE 25	25	1200	7	223511 0001
HKE 30	30	2,000	12	223512 0001



Precision is our drive

Our technically sophisticated ball screw drives are high-precision mechanical drive elements for many areas of technology and mechanical engineering, which have proven themselves successfully in demanding industrial practice for decades. The principle of the ball screw drive is very simple. And yet the requirements and designs of the drive solution are so diverse in their practical applications.

With our product range, we offer you a suitable drive solution for practically every movement task - regardless of the requirements for pitch, speed, rigidity, precision, service life and reliability. We specialize in providing you with an adequate solution for your application.

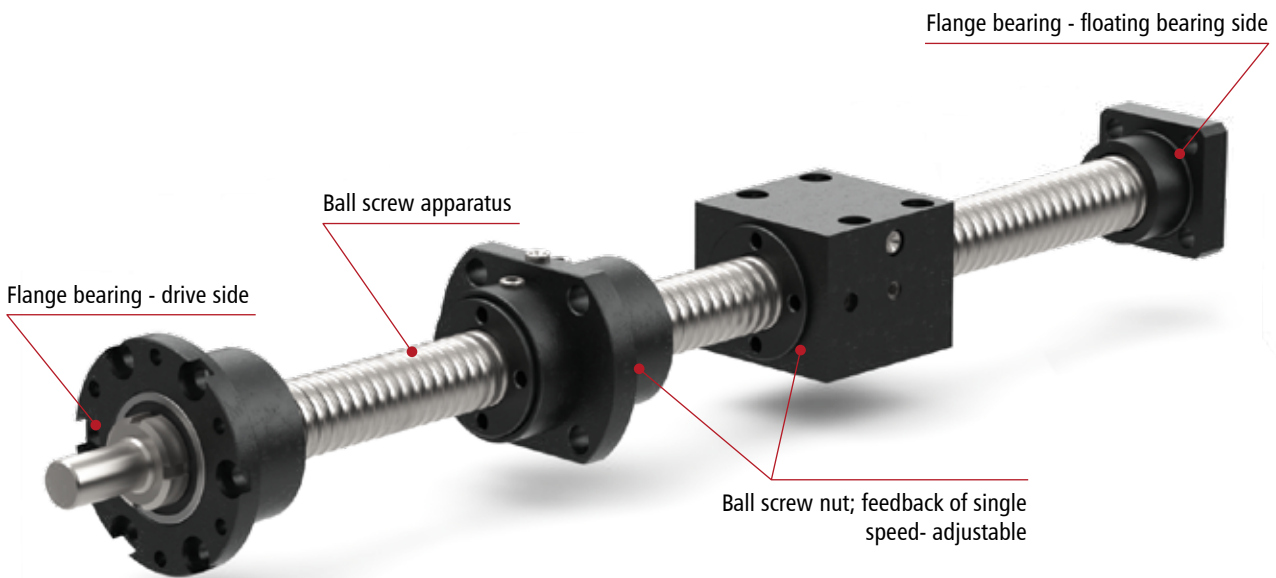

Information

The ball screw nuts of the **company isel Germany GmbH** are of high quality, precise and wear-resistant (hardened and ground). Together with the ball screw spindles, they convert rotary movements into linear movements by producing an extremely low friction-level.

The ball screw nut is inserted into the respective clamping block and positioned and fastened by means of a stud bolt. The ball screw nuts have multiple ball circuits equipped with an internal ball return.

A set screw on the clamping block allows the run of the ball screw spindle to be adjusted without any clearance.

The repetition accuracy is less than 0.01 mm over a length of 300 mm. A lubricating nipple is attached to the clamping block for the lubrication of the linear drive.

The ball screw spindles are manufactured on modern machines in a rolled design, and then hardened and polished.

Our linear drives are technically mature and have proven themselves in their practical application for more than 25 years.



Process know-how and vertical integration

Our ball screw spindles are technically mature, powerful and extensively proven through use in automation systems: With ball screw drives, isel Germany GmbH has created a core competence with a lot of know-how in design and production.

With modern production facilities, we carry out all workprocesses (rolling, hardening and polishing) as well as the individual end-processing effectively and customer-specifically in order to offer you the optimal solution for your design task.

Just give us a call to discuss your individual application and possible solutions with us. Our experienced team is always at your disposal for details and questions.

Our design department checks all the technical requirements and coordinates with the production engineers so that your order can be quickly and flexibly integrated into the production process.

We have been manufacturing ball screw spindles on modern CNC-controlled production machines and with robotsupport for more than 25 years. Certified processes, permanent monitoring and



optimization of production processes as well as the most modern 3D measuring machines guarantee consistent quality to meet customer requirements.

Our long-standing customers include companies from the following branches:

- Mechanical and apparatus engineering
- Medical technology
- Electronics industry
- Semiconductor industry

- Wood processing
- Training • and many more...



 YouTube



Ball screw spindles Ø 12, 16, 20, 25 mm

- rolled, hardened, and polished
- Material CF 53, hardened by induction (HRC 60±2)
- Available in lengths of up to 3052 mm (inside the grid of 100 mm, special lengths are available upon request!)
- End processing according to the isel standard or based on customer specifications
- Standard tolerance class according to ISO 7



Order key

211 1XX XXXX

Diameter
 2 = 12 mm
 3 = 16 mm
 4 = 25 mm
 5 = 20 mm

Spindle gradient
 2 = 2.5 mm (only for Ø 12, 16 mm)
 3 = 4 mm (only for Ø 16 mm)
 4 = 5 mm
 5 = 10 mm (not with Ø 12 mm)
 6 = 20 mm (not with Ø 12 mm)

End machining
 0 = unprocessed
 1 = one-sided processing
 2 = two-sided processing (only for Ø 12, 25 mm)
 5 = two-sided processing (only for Ø 16, 20 mm) suitable for all feeds (aluminum profile length +78 mm)

Lengths
 e.g. 045 = 452 mm
 086 = 868 mm
 305 = 3052 mm (shortened by the last digit)

See "Available lengths" for permissible combinations.

Dimensional drawings

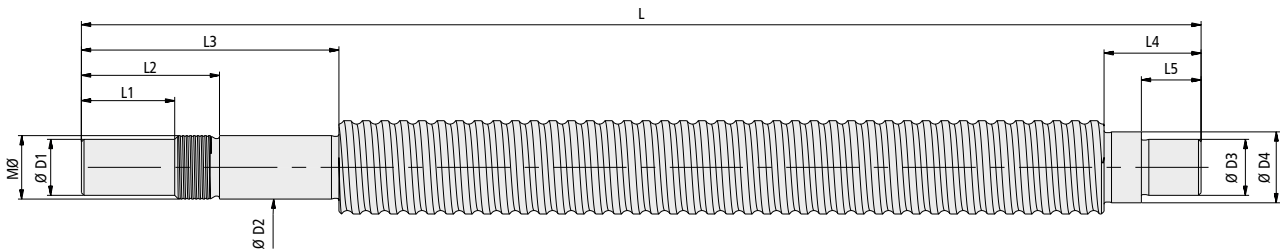

	Gradient	L [max.]	L1	L2	L3	L4	L5	M	D1	D2	D3	D4
Ø 12	2.5 / 5	1552	10	20	40	12	-	M8 x 1	6.35 h7	8 h6	-	7 h6
Ø 16	2.5 / 4 / 5 / 10 / 20	3068	18	31	52	28	-	M10 x 0.75	8 h7	10 h6	-	12 h6
Ø 20	5 / 10 / 20	3052	20	32	55	27.5	-	M12 x 1	10 h7	12 h6	-	12/14 h6
Ø 25	5 / 10 / 20	3000	25	37	69	26	16	M17 x 1	15 h7	17 h6	15 j6	19 h11

Available lengths

End processing inside a grid of 100 mm	Ø 12 mm	Ø 16 mm	Ø 20 mm	Ø 25 mm
without	252 - 1552 mm	352 - 3052 mm	252 - 3052 mm	300 - 3000 mm
one-sided	252 - 552 mm	352 - 1052 mm	252 - 1052 mm	352 - 1052 mm
two-sided	252 - 1552 mm	368 - 3068 mm	252 - 3052 mm	295 - 2995 mm



Flange bearing

Flange bearing - drive side



Flange bearing - floating bearing side



- Bearing of the ball screw spindle (fixed-loose bearing)
- **Flange bearing, drive side (fixed bearing):** bearing bush equipped with two pressed-in angular ball bearings in an O arrangement
- **Flange bearing opposite bearing side (floating bearing):** bearing bush equipped with a pressed-in needle bearing

drive side and lock nut

	Construction	B	L	L1	D1	D2	T1	T2	G1	G2	d	Thread	Item number
Ø 12	rectangular	36	19.5	-	-	8	38.2	-	45°	90°	4 x Ø 4.5	-	216504 0030
Ø 16	rectangular	45	23	6	35	10	45	-	45°	90°	4 x Ø12 4U / Ø7	-	216504 0001
Ø 16	round	62	23	6	35	10	45	54	45°	90°	4 x Ø12 4U / Ø7	4 X M6	216504 0003
Ø 20	round	64	23	8	39.5	12	50	54	45°	90°	4 x Ø12 4U / Ø7	4 X M6	216504 0031
Ø 25	round	72	34	8	53	17	62	62	30°	60°	4 x Ø12 4U / Ø7	6 x M6	216504 0006

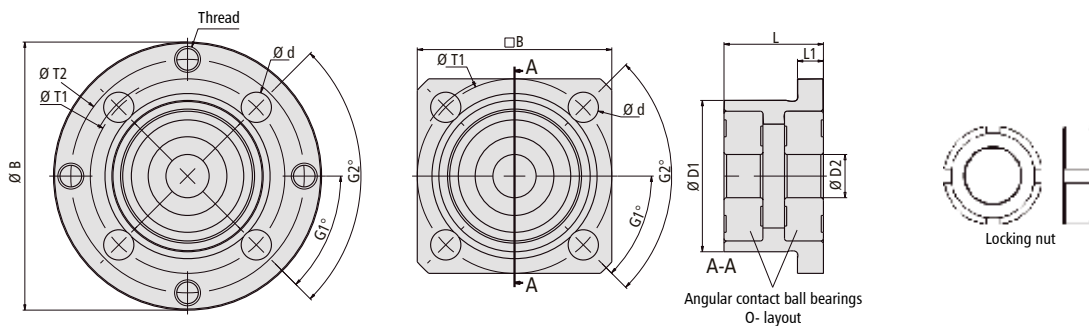

Floating bearing side

	B	L	L1	L2	L3	L4	D1	D2	T	d	Item number
Ø 12	35	20	8	6	6.5	0.5	28	7	38.2	Ø7.5 x 4U / Ø4.5	216504 0032
Ø 16	45	29	12	4.5	9.5	0.5	35	12	45	Ø 12 x 4U / Ø 7	216504 0002
Ø 20	50	29.5	12	4.5	5	1.5	35	12	50	Ø 12 x 4U / Ø 7	216504 0033
Ø 25	45	29	12	8	10	0	35	15	45	Ø 12 x 4U / Ø 7	216504 0005

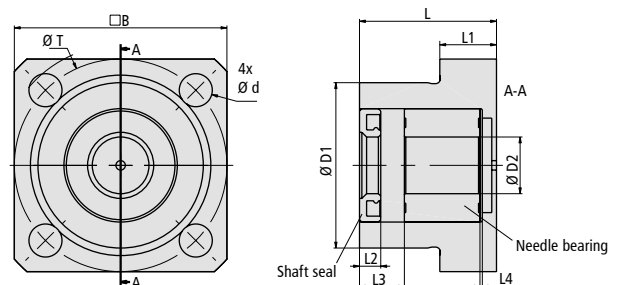



Ball screw nuts equipped with single thread return

- Material 16MnCr5, ground
- Constructions as a round nut
- Nut gradients: 2.5 / 5 / 10 / 20 mm
- Balls with internal deflections

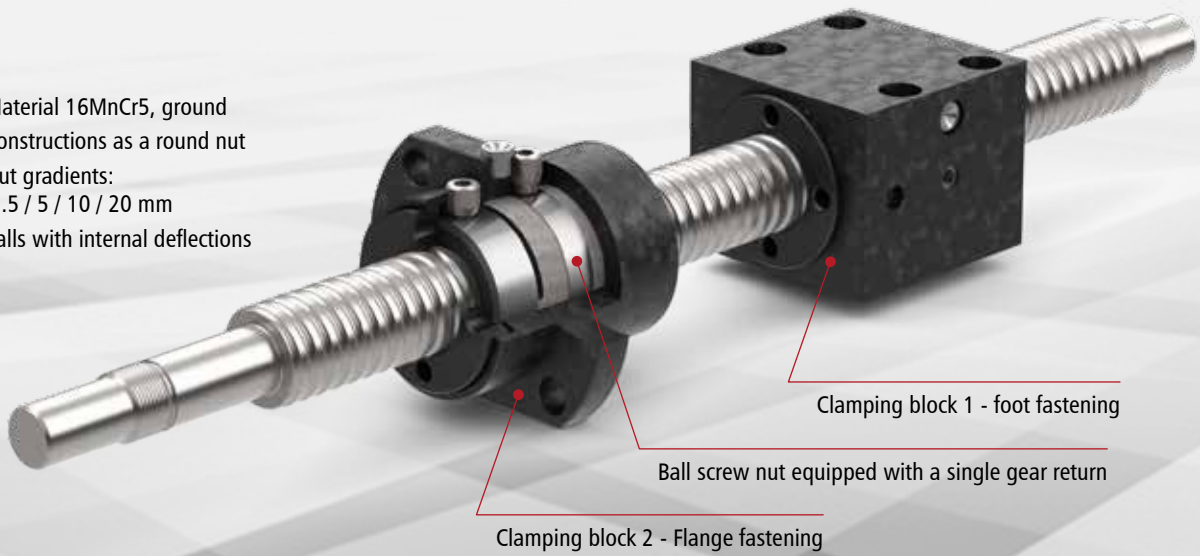

Scraper

- Constructions for ball screw nuts
Ø 12, 16, 20, 25 mm (PU = 2 pieces)

- Ø 12 mm Part No.: 213500 0003
- Ø 16 mm Part No.: 213500 0001
- Ø 20 mm Part No.: 213500 0002
- Ø 25 mm Part No.: 213700 9000

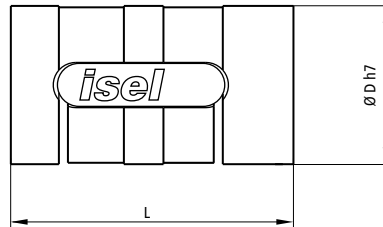

drive side and lock nut

	Gradient	D	L	dyn. load rating [N]	stat. load rating [N]	Item number
Ø 12	2.5	24	37.5	1900	3000	213412 0003
	5			1300	2,000	213412 0005
Ø 16	2.5	28	50	3,500	5500	213503
	4			4600	7200	213514
	5			4600	7200	213505
	10			4200	6500	213510
Ø 20	20	33	50	1900	2,500	213520
	5			5000	9000	213420 0005
	10			4,500	8,000	213420 0010
Ø 25	5	38	50	5,100	12,600	213700 0005
	10			5,100	12,600	213700 0010
	20			3,570	8,800	213700 0020



... and matching clamping blocks



- Clamping blocks for foot and flange fastening
- Material steel, blued
- Constructions for ball screw spindles
Ø 12, 16, 20, 25 mm

Foot fastening

	M	L	B	C	H1	L1	L2	L3	Clamping nut	Part No.
Ø 12	24	37.5	44	29	14.5	7	20	31	-	213400
Ø 16	28	54	47	33	16.5	14.5	25	35	-	213500
Ø 20	33	61.5	53	40	20	10	30	40	1x	213600
Ø 25 - gradient 5/10	38	60	60	49.5	25	10	30	46	1x	213700 9001
Ø 25 - gradient 20	38	80	60	50	25	10	50	46	1x	213700 9002

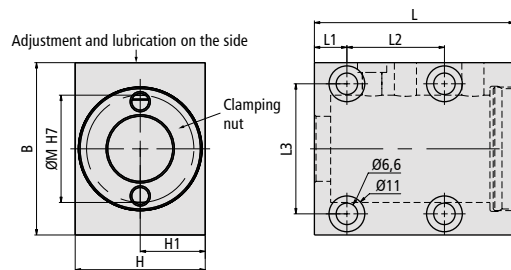

Flange fastening

	M	L	B	C	d	T	D1	D2	D3	L1	L2	Clamping nut	Part No.
Ø 12	24	37.5	53	42	4.5	45	35	37 g6	35	3	24.5	-	213401
Ø 16	28	50	62	48	6.6	51	39	40 g6	39	11.6	28.4	-	213501
Ø 20	33	60.5	67	53	6.6	56	44	45 g6	44	16	34.5	1x	213601
Ø 25 - gradient 5/10	38	60	80	62	9	65	49	50 f9	50f9	32.25	17.75	1x	213700 9003
Ø 25 - gradient 20	38	80	80	62	9	65	49	50 f9	50f9	52.25	17.75	1x	213700 9004

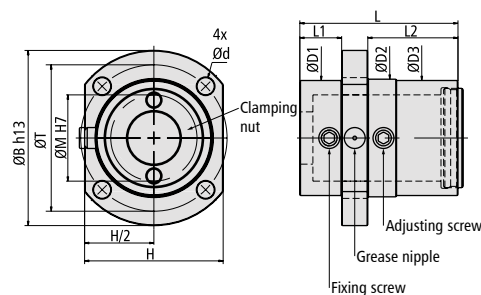



Strong profiles to be used for many applications



Modular flexibility and highest level of stability

From aluminum square profiles which can be used universally to groove plates flatly milled on both sides and a selection of connection solutions: The modular profile components are coordinated with one another so to offer you a wide range of combination options when it comes to the design of your working environment. By means of the aluminum profiles, complete mounting systems equipped with all needed applications can be designed - according to your requirements.

Light, compact and stable: With a selection of robust aluminum square and round profiles, clamping connections and the range of accessories, the profiles open up every conceivable freedom in the design of ergonomic, efficient and safe working environments. Thick-walled, distortion-free and dimensionally stable: Combine stabilizing rectangular profiles and grooved plates to reach a universal precision, clamping and machining surfaces that can be used in all machines and can be used for conversions and extensions as well if needed.







Panel profiles PP 50 - PP 250

- for rapid and easy assembly of frames, tables as well as racks
- Aluminum, naturally anodized
- Manufactured according to the standard DIN EN 12020-2
- light and very strong
- upright, particularly suitable as load-bearing cladding, may absorb higher loads as well
- With our profile connections, very strong connections that are resistant to tension, torsion and bending are produced using profile bores and Allen screws in connection with PS profiles
- Profile cutting upon request



Accessories: see page 112

Dimensional drawings

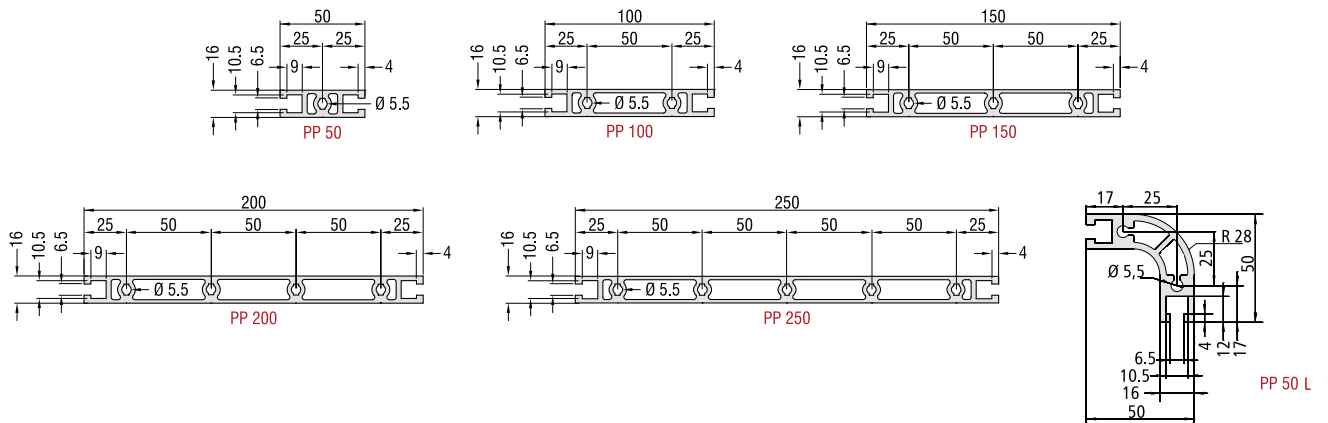

Technical data	PP 50 L	PP 50	PP 100	PP 150	PP 200	PP 250
Dimensions (W x H)	50 x 50 mm	50 x 16 mm	100 x 16 mm	150 x 16 mm	200 x 16 mm	250 x 16 mm
Length	up to 3 meters (special lengths upon request)					
Weight	≈ 1.7 kg/m	≈ 1.1 kg/m	≈ 1.9 kg/m	≈ 2.6 kg/m	≈ 3.4 kg/m	≈ 4.1 kg/m
Features	2 T-slot indents 2 hollow feeds Ø 5.5 mm for M6 screw	2 T-slot indents 1 hollow feed Ø 5.5 mm for M6 screw	2 T-slot indents 2 hollow feeds Ø 5.5 mm for M6 screw in a 50 grid	2 T-slot indents 3 hollow feeds Ø 5.5 mm for M6 screw in a 50 grid	2 T-slot indents 4 hollow feeds Ø 5.5 mm for M6 screw in a 50 grid	2 T-slot indents 5 hollow feeds Ø 5.5 mm for M6 screw in a 50 grid
Moment of inertia I_x	13.25 cm ⁴	8.13 cm ⁴	67.27 cm ⁴	213.92 cm ⁴	482.77 cm ⁴	908.52 cm ⁴
Moment of inertia I_y	13.25 cm ⁴	1.37 cm ⁴	2.46 cm ⁴	3.55 cm ⁴	4.64 cm ⁴	5.74 cm ⁴
Resistance moment W_x	4.39 cm ³	3.25 cm ³	13.45 cm ³	28.52 cm ³	48.27 cm ³	72.68 cm ³
Resistance moment W_y	4.39 cm ³	1.71 cm ³	3.08 cm ³	4.44 cm ³	5.80 cm ³	7.17 cm ³

Order data

Part No. for L=1000mm	201045 1000	201040 1000	201041 1000	201042 1000	201043 1000	201009 1000
Part No. for L=3000mm (Raw profile length L=3050...3,100 mm)	201045 3000	201040 3000	201041 3000	201042 3000	201043 3000	201009 3000



Universal profiles PU 25 / PU 50



- for rapid and easy assembly of frames, tables as well as racks
- Aluminum, naturally anodized
- Manufactured according to the standard DIN EN 12020-2
- light, compact, and stable
- universally applicable
- suitable for higher loads
- With our clamping connections, very strong connections between the profiles which are resistant to tension, torsion as well as bending are produced by using profile bores and clamping elements
- Profile cutting upon request

Accessories: see page 112

Dimensional drawings

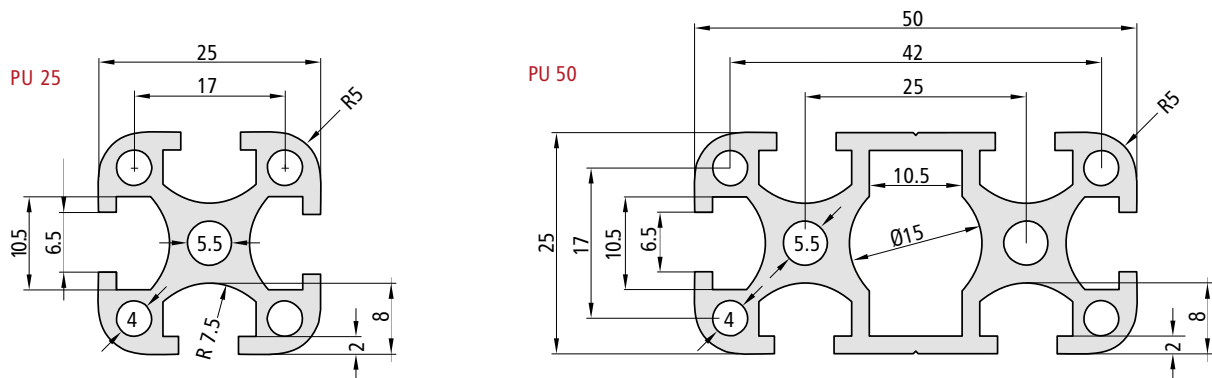

Technical data	PU 25	PU 50	Order data	PU 25	PU 50
Dimensions (W x H)	25 x 25 mm	50 x 25 mm	Part No. for L=1000mm	200001 1000	200002 1000
Length	up to 3 meters (special lengths upon request)		Part No. for L=3000mm (Raw profile length L=3050...3,100 mm)	200001 3000	200002 3000
Weight	≈ 0.7 kg/m	≈ 1.3 kg/m			
Features	4 T-slot inserts for sliding nuts M6 1 hollow feeds, Ø 5.5 mm for M6	6 T-slot inserts for sliding nuts M6 2 hollow feeds, Ø 5.5 mm for M6			
Moment of inertia I_x	1.43 cm ⁴	10.99 cm ⁴			
Moment of inertia I_y	1.43 cm ⁴	2.81 cm ⁴			
Resistance moment W_x	1.14 cm ³	4.40 cm ³			
Resistance moment W_y	1.14 cm ³	2.25 cm ³			



T-slot plates PT 25

- Universal precision, clamping and machining surface
- Aluminum, naturally anodized
- T-slot grid 25 mm
- Manufactured according to the standard DIN EN 12020-2
- Milled on both sides
- Can be used on all machines
- Thick-walled, distortion-free and extremely dimensionally stable
- Profile cutting upon request
- Option:
 - Drain channel for small amounts of liquid



Accessories: see page 112

Dimensional drawings

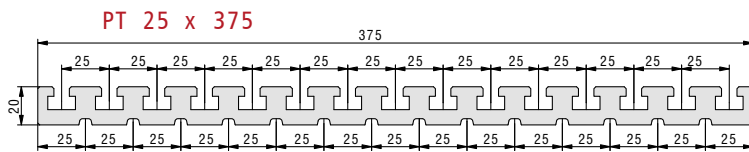
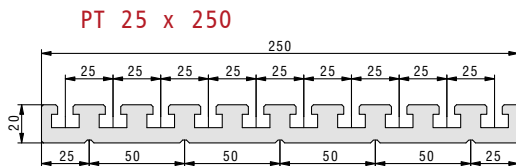
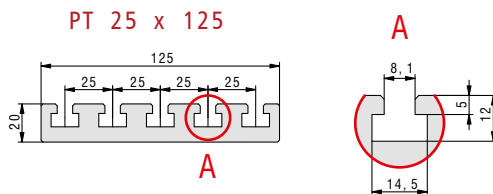

Technical data

PT 25

Dimensions (W x H)	125 x 20 mm	250 x 20 mm	375 x 20 mm
Length	up to 3 meters (special lengths upon request)		
Weight	≈ 4.8 kg/m	≈ 9.6 kg/m	≈ 13.7 kg/m
Features	T-slot indentations on one side in a grid of 25 mm		
Moment of inertia I_x	243.36 cm ⁴	1848.50 cm ⁴	5996.01 cm ⁴
Moment of inertia I_y	6.46 cm ⁴	12.77 cm ⁴	17.90 cm ⁴
Resistance moment W_x	38.94 cm ³	147.88 cm ³	319.79 cm ³
Resistance moment W_y	6.46 cm ³	12.77 cm ³	17.90 cm ³

Order key PT 25

W 125 x H 20 mm:

201014 ~~XXXX~~
 e.g. 0400 = L 400
 3000 = L 3000*

Length in mm (in a grid of 100mm)

W 250 x H 20 mm:

201018 ~~XXXX~~
 e.g. 0400 = L 400
 3000 = L 3000*

Length in mm (in a grid of 100mm)

W 375 x H 20 mm:

201020 ~~XXXX~~
 e.g. 0400 = L 400
 3000 = L 3000*

Length in mm (in a grid of 100mm)

*Raw profile length L = 3050...3100 mm



T-slot plates PT 50

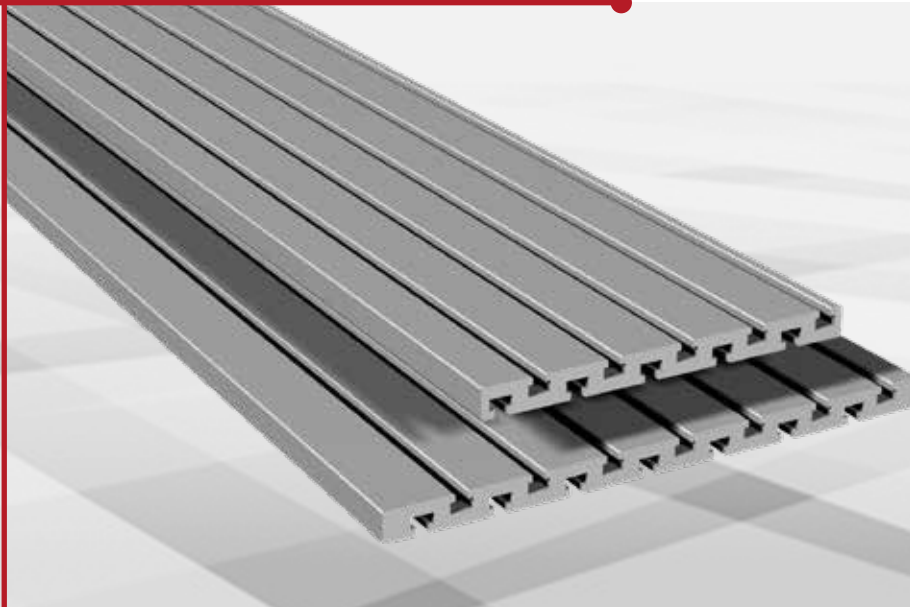

- Universal precision, clamping and machining surface
- Aluminum, naturally anodized
- T-slot grid 50 mm
- Manufactured according to the standard DIN EN 12020-2
- Milled on both sides
- Can be used on all machines
- Thick-walled, distortion-free and extremely dimensionally stable
- Profile cutting upon request

Accessories: see page 112

Dimensional drawings

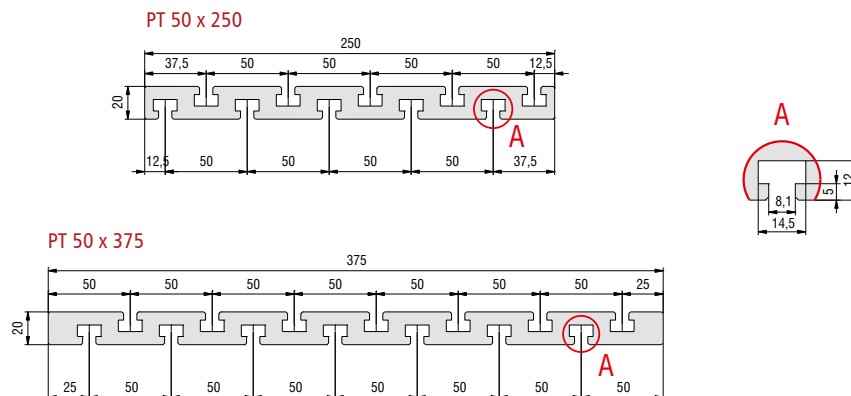

Technical data

PT 50

	250 x 20 mm	375 x 20 mm
Dimensions (W x H)	250 x 20 mm	375 x 20 mm
Length	up to 3 meters (special lengths upon request)	
Weight	≈ 10.0 kg/m	≈ 14.8 kg/m
Features	T-slot indentations on both sides in a 50 mm grid	
Moment of inertia I_x	2062.99 cm ⁴	6745.96 cm ⁴
Moment of inertia I_y	13.85 cm ⁴	20.63 cm ⁴
Resistance moment W_x	165.04 cm ³	359.78 cm ³
Resistance moment W_y	13.85 cm ³	20.63 cm ³

Order key PT 50

W 250 x H 20 mm:

201016 ~~XXXX~~

e.g. 0400 = L 400

3000 = L 3000*

Length in mm (in a grid of 100mm)

W 375 x H 20 mm:

201019 ~~XXXX~~

e.g. 0400 = L 400

3000 = L 3000*

Length in mm (in a grid of 100mm)

*Raw profile length L=3050...3100 mm



Rectangular profiles type RE 40

- Universal precision, clamping and machining surface
- as a stabilizer in machine and subframe constructions
- Aluminum, naturally anodized
- Manufactured according to the standard DIN EN 12020-2
- light, very stable
- Numerous applications are possible, if combined with the accessories
- Profile cutting upon request

Accessories: see page 112



Dimensional drawings

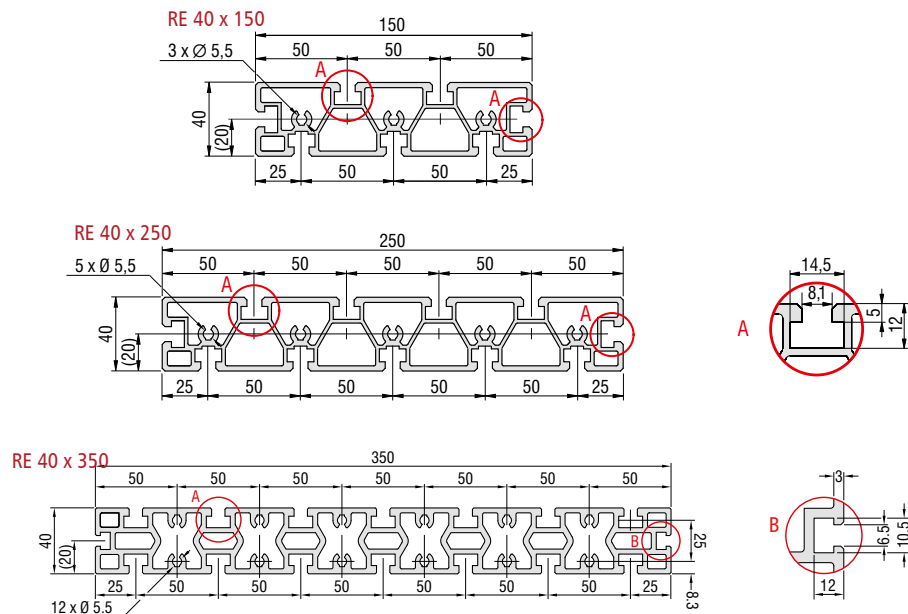

Technical data

	RE 40		
	150 x 40 mm	250 x 40 mm	350 x 40 mm
Dimensions (W x H)	150 x 40 mm	250 x 40 mm	350 x 40 mm
Length	up to 3 meters (special lengths upon request)		
Weight	≈ 4.8 kg/m	≈ 7.6 kg/m	≈ 13.38 kg/m
Features	Several hollow chambers and T-slot indentations for sliding nuts or threaded strips M6 as well as front indentations for M6 screws		
Moment of inertia I_x	393.70 cm ⁴	1654.53 cm ⁴	5.626.00 cm ⁴
Moment of inertia I_y	33.42 cm ⁴	54.18 cm ⁴	97.45 cm ⁴
Resistance moment W_x	52.49 cm ³	131.64 cm ³	321.48 cm ³
Resistance moment W_y	16.71 cm ³	27.09 cm ³	48.50 cm ³

Order data

	L 1000 mm	L 3000*
RE 40 W 150 x H 40mm	201035 1000	201035 3000
RE 40 W 250 x H 40 mm	201030 1000	201030 9000
RE 40 W 350 x H 40 mm	201031 1000	201031 3000

*Raw profile length L=3050...3,100 mm



Rectangular profiles type RE 65



- Universal precision, clamping and machining surface
- as a stabilizer in machine and subframe constructions
- Aluminum, naturally anodized
- Manufactured according to the standard DIN EN 12020-2
- light, very stable
- Milled on both sides
- Numerous applications are possible, if combined with the accessories
- Profile cutting upon request

Accessories: see page 112

Dimensional drawings

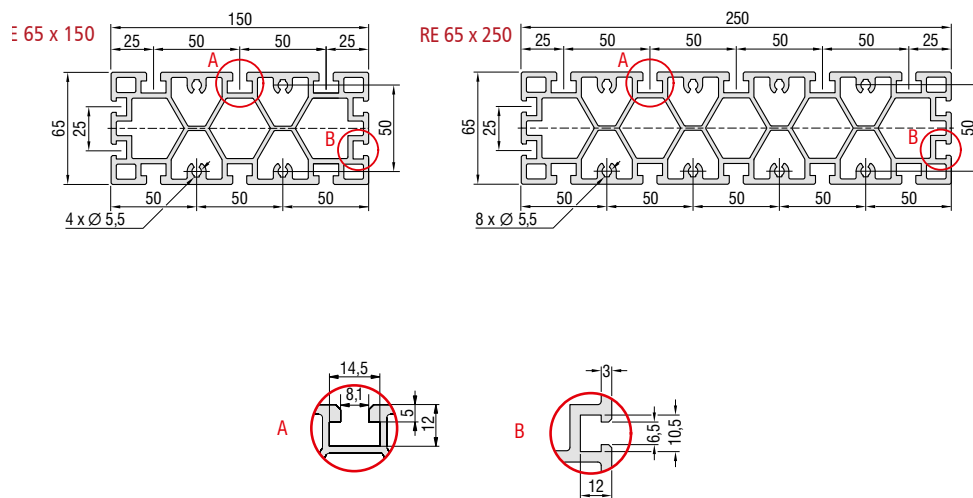

Technical data

RE 65

	150 x 65 mm	250 x 65 mm
Dimensions (W x H)	150 x 65 mm	250 x 65 mm
Length	up to 3 meters (special lengths upon request)	
Weight	≈ 7.7 kg/m	≈ 12.4 kg/m
Features	Several hollow chambers and T-slot indentations for sliding nuts or threaded strips M6 as well as front indentations for M6 screws	
Moment of inertia I_x	633.47 cm ⁴	2,658.48 cm ⁴
Moment of inertia I_y	148.87 cm ⁴	243.85 cm ⁴
Resistance moment W_x	84.46 cm ³	212.68 cm ³
Resistance moment W_y	45.83 cm ³	75.03 cm ³

Order data

L 1000 mm

L 3000*

RE 65 W 150 x H 65 mm	201034 1000	201034 3000
RE 65 W 250 x H 65 mm	201032 1000	201032 3000

*Raw profile length L=3050...3100 mm



Lightweight frame profiles PL 40 / PL 80

- for rapid and easy assembly of frames, tables as well as racks
- Aluminum, naturally anodized
- Manufactured according to the standard DIN EN 12020-2
- light, compact, and stable
- suitable for higher loads
- With our clamping connections, very strong connections between the profiles which are resistant to tension, torsion as well as bending are produced by using profile bores and clamping elements
- Profile cutting upon request



Option: powder coatings
Accessories: see page 112

Dimensional drawings

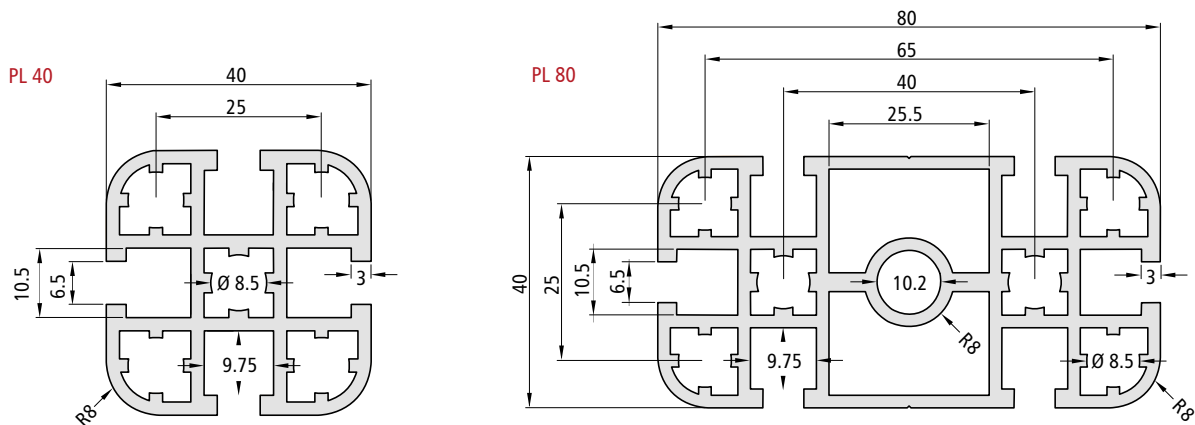

Technical data	PL 40	PL 80	Order data	L 1000 mm	L 3000*
Dimensions (W x H)	40 x 40 mm	80 x 40 mm	PL 40		
Length	up to 3 meters (special lengths upon request)		W 40 x H 40 mm	200008 1000	200008 3000
Weight	≈ 1.5 kg/m	≈ 2.9 kg/m	PL 80		
Features	4 T-slot inserts for sliding nuts M6 5 hollow feeds, Ø 8.5 mm for M10	6 T-slot inserts for sliding nuts M6 6 hollow feeds, Ø 8.5 mm for M10, Ø 10.2 mm for M12	W 80 x H 40 mm	200009 1000	200009 3000
Moment of inertia I_x	8.38 cm ⁴	64.40 cm ⁴	*Raw profile length L=3050...3100 mm		
Moment of inertia I_y	8.38 cm ⁴	16.36 cm ⁴			
Resistance moment W_x	4.19 cm ³	16.10 cm ³			
Resistance moment W_y	4.19 cm ³	8.18 cm ³			



Rectangular profiles PS 50 / PS 80



- for rapid and easy assembly of frames, tables as well as racks
- Aluminum, naturally anodized
- Manufactured according to the standard DIN EN 12020-2
- light, compact, and stable
- suitable for higher loads
- With our clamping connections, very strong connections between the profiles which are resistant to tension, torsion as well as bending are produced by using profile bores and clamping elements
- Profile cutting upon request

Option: powder coatings

Accessories: see page 112

Dimensional drawings

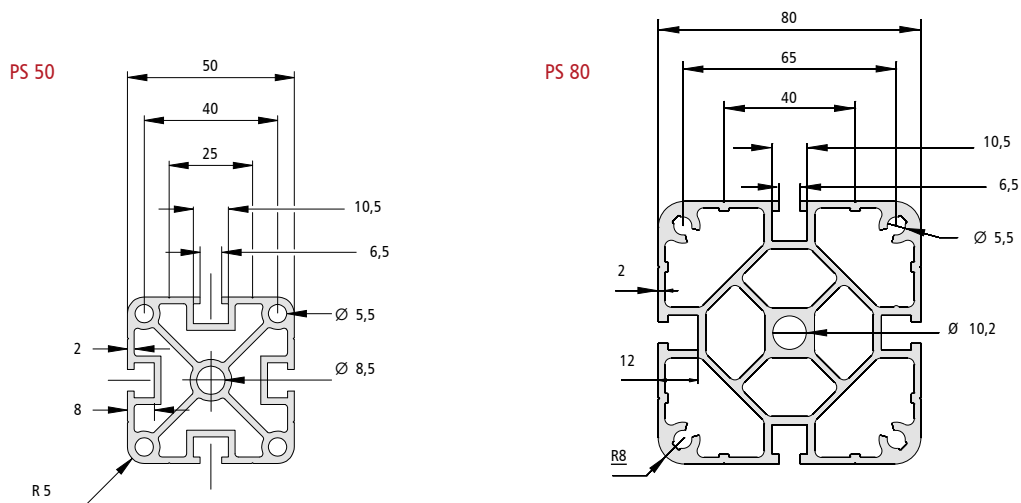

Technical data	HP 50	HP 80	Order data	L 1000 mm	L 3000*
Dimensions (W x H)	50 x 50 mm	80 x 80 mm	HP 50		
Length	up to 3 meters (special lengths upon request)		W 50 x H 50 mm	200003 1000	200003 3000
Weight	≈ 2.3 kg/m	≈ 4.5 kg/m	HP 80		
Features	4 T-slot inserts for sliding nuts M6 4 hollow feeds, Ø 5.5 mm for M6, Ø 8.5 mm for M10	4 T-slot inserts for sliding nuts M6 4 hollow inserts, Ø 5.5 mm for M6, Ø 10.2 mm for M12	W 80 x H 80 mm	200014 1000	200014 3000
Moment of inertia I_x	22.06 cm ⁴	111.80 cm ⁴	*Raw profile length L=3050...3100 mm		
Moment of inertia I_y	22.06 cm ⁴	111.80 cm ⁴			
Resistance moment W_x	8.82 cm ³	27.95 cm ³			
Resistance moment W_y	8.82 cm ³	27.95 cm ³			



Stand profiles HP 100 / HP 140

- for rapid and easy assembly of frames, tables as well as racks
- Aluminum, naturally anodized
- Manufactured according to the standard DIN EN 12020-2
- light, compact, and stable
- suitable for higher loads
- With our clamping connections, very strong connections between the profiles which are resistant to tension, torsion as well as bending are produced by using profile bores and clamping elements
- Profile cutting upon request



Option: powder coatings
Accessories: see page 112

Dimensional drawings

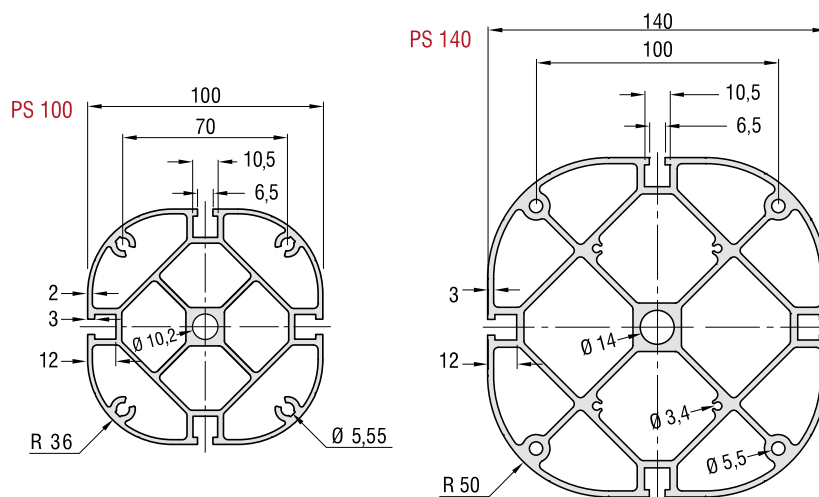

Technical data	HP 100	HP 140	Order data	L 1,000 mm	L 3,000*
Dimensions (W x H)	100 x 100 mm	140 x 140 mm	HP 100		
Length	up to 3 meters (special lengths upon request)		W 100 x H 100 mm	200015 1000	200015 3000
Weight	≈ 5.1 kg/m	≈ 9.2 kg/m	HP 140		
Features	4 T-slot inserts for sliding nuts M6 4 hollow feeds, Ø 5.55 mm for M6 Hollow feeds, Ø 10.2 mm for M12	4 T-slot inserts for sliding nuts M6 4 hollow feeds, Ø 5.5 mm for M6 4 hollow feeds, Ø 3.4 mm for M4 Hollow feeds, Ø 10.2 mm for M12	W 140 x H 140 mm	200016 1000	200016 3000
Moment of inertia I_x	163.00 cm ⁴	601.80 cm ⁴	*Raw profile length L=3050...3,100 mm		
Moment of inertia I_y	163.00 cm ⁴	598.11 cm ⁴			
Resistance moment W_x	32.60 cm ³	85.97 cm ³			
Resistance moment W_y	32.60 cm ³	85.44 cm ³			



Working tables AT 1 / AT 2 / AT 3



Working tables AT for clamping devices, clamping devices, for measuring, checking, testing, etc.

- Base made of PS series aluminum profiles equipped with braces made of PP series aluminum panel profiles
- Table top made of aluminum rectangular profile series RE 40 x 250 mm equipped with T-slots

Accessories: see page 112

Dimensional drawings

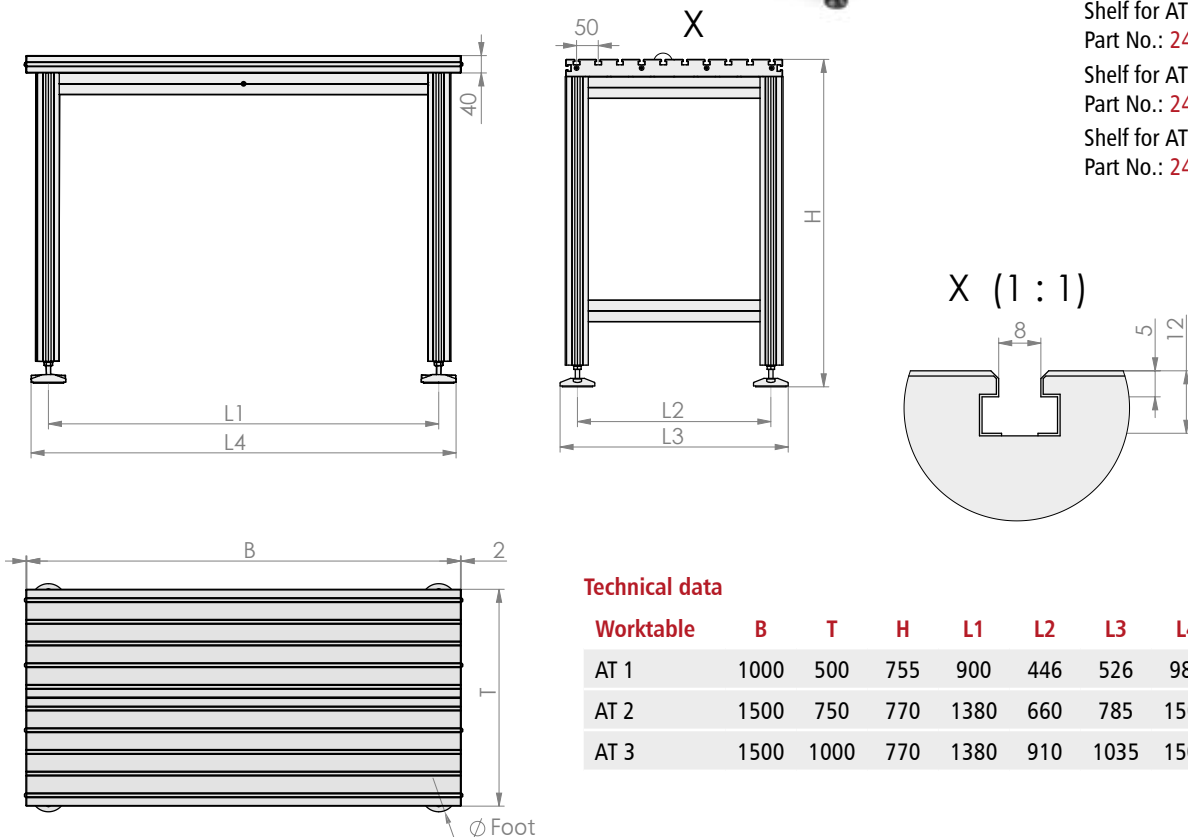

Accessories

- Shelf for AT 1
Part No.: 248551 0010
- Shelf for AT 2
Part No.: 248551 0012
- Shelf for AT 3
Part No.: 248551 0013

Technical data

Worktable	B	T	H	L1	L2	L3	L4	Ø Foot
AT 1	1000	500	755	900	446	526	980	80
AT 2	1500	750	770	1380	660	785	1505	125
AT 3	1500	1000	770	1380	910	1035	1505	125

Order data

Worktable	Dimensions WxDxH [mm]	Load capacity: distributed load [kg]	Weight [kg]	Part No.
AT 1	1000 x 500 x 755	200	≈ 30	248550 0010
AT 2	1500 x 750 x 770	400	≈ 60	248550 0012
AT 3	1500 x 1000 x 770	400	≈ 75	248550 0013



Assembly table MT2



Assembly tables for clamping fixtures, clamping devices, for measuring, checking, testing, etc.

- Base frame made of PS series aluminum profiles with struts made of PP series aluminum panel profiles
- Table top and rear panel made of RE series aluminum rectangular profiles with T-slot inserts

Accessories: see page 112

Dimensional drawings

MT 2 - PS80

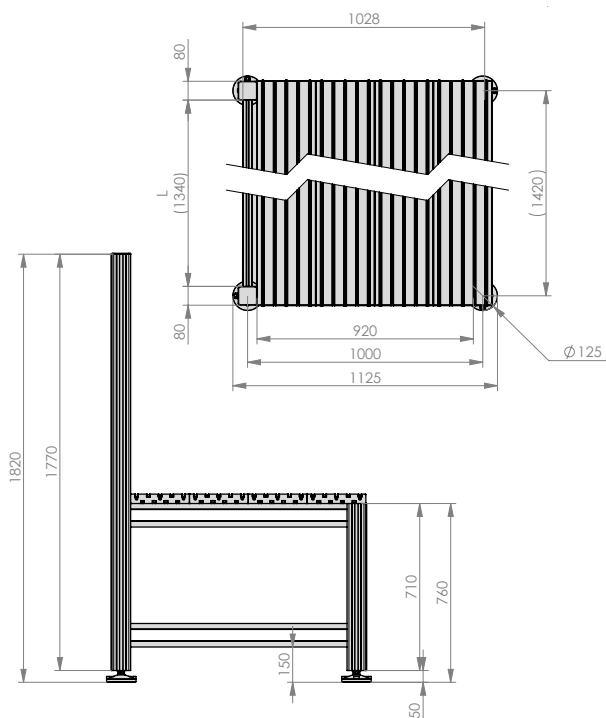

MT 2 - PS50

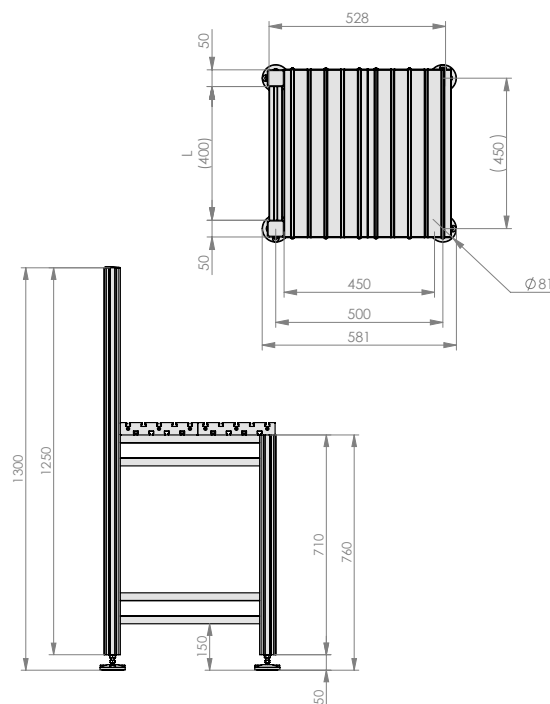

Order data

MT 2 assembly table with T-slot plate	Table surface [mm]	Part No.
MT 2 - PS80 - 1500	1500 x 1000	248550 1001
MT 2 - PS80 - 2000	2000 x 1000	248550 1002
MT 2 - PS80 - 2500	2500 x 1000	248550 1003
MT 2 - PS80 - 3000	3000 x 1000	248550 1004

Order data

MT 2 assembly table with T-slot plate	Table surface [mm]	Part No.
MT 2 - PS50 - 500	500 x 500	248550 1005
MT 2 - PS50 - 1000	1000 x 500	248550 1006
MT 2 - PS50 - 1500	1500 x 500	248550 1007
MT 2 - PS50 - 2000	2000 x 500	248550 1008



Assembly table MT2 | variants with T-slot plate



PS50 - 500



PS50 - 1000



PS50 - 1500



PS50 - 2000



MT 2 - PS80 - 1500



MT 2 - PS80 - 2000



MT 2 - PS80 - 2500



MT 2 - PS80 - 3000



Accessories | for panel profiles (PT and RE)

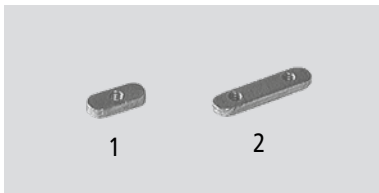

Sliding nut M6 (Figure 1)

- L 25 × W 13 × H 5
- Galvanised
- VE 50 units
- For PT/RE 40, 65

Part no.: 209004 0001

2 × M6 sliding nuts (Figure 2)

- L 45 x B 13 x H 6
- verzinkt
- 2 x M6 Ra 25mm
- VE 25 Stück
- für PT / RE 40, 65

Part no.: 209005 0001



M5/M6 sliding nuts

- Galvanised
- VE 20 units
- for PT25 , PT 50, PS 200, RE 40 and RE 65 (securing only possible at the top)

with spring

Part no.: 209005 0002 (M5/ Figure 1)

Part no.: 209005 0003 (M6/ Figure 2)

with large chamfer

Part no.: 209005 0004 (M6/ Figure 3)

in rhombus shape

Part no.: 209005 0006 (M6/ Figure 4)

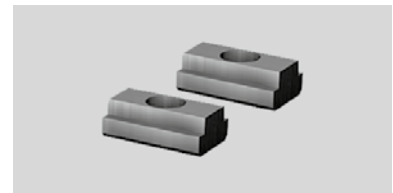

M6 T-keyways

- DIN 508
- Hardened
- VE 20 units
- for PT/ RE 40, 65

Part no.: 209119 0003



M6 tapped rail

- 13 x 6 mm
- Galvanised
- M6 Ra 50 mm
- VE 3 units at 1 m
- for PT/RE 40, 65

Part no.: 209010

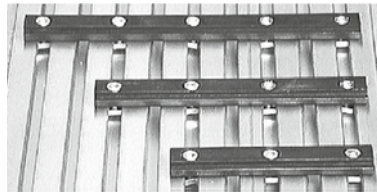

Stop rail

- galvanised
- W 20 × H 10
- Ra 50
- VE 2 units and fixing material

L 125 mm | Part no.: 290021 0125

L 175 mm | Part no.: 290021 0175

L 225 mm | Part no.: 290021 0225

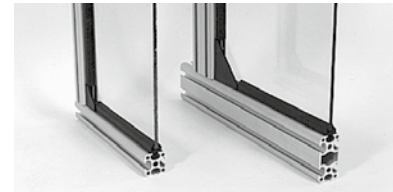

Black edging strip

- black, 1-part
- For plate thicknesses 3 - 4 mm
- VE 10 m
- for RE-profiles

Part no.: 209202 0001



Spanneisen SE

- mit Stellschraube M6
- VE 2 Stück
- für RE / PT

Part no.: 290051

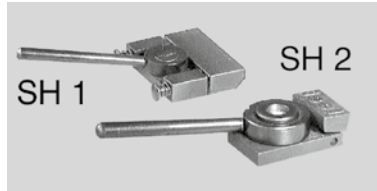

Hand lever clamping device

- for RE/PT

SH 1 | Part no.: 290001

SH 2 | Part no.: 290002



Accessories | for pillar and panel profiles (PP, PU, PL and PS)

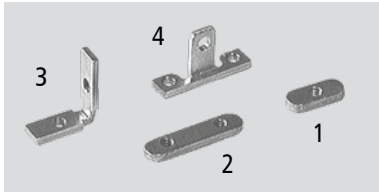

M6 sliding nut (Figure 1)

- L25 × W10 × H3.5
- Galvanised
- VE 100 units
- all except PT/RE 40, 65

Part no.: 209001 0005

2 × M6 sliding nuts (Figure 2)

- L45 × W10 × H3.5
- Galvanised
- VE 50 units
- for all except PT/RE 40, 65

Part no.: 209002 0004

M5 sliding nut

- L25 × W10 × H3.5
- Galvanised
- VE 20 units
- for all except PT/RE 40, 65

Part no.: 209006 0001

Angle sliding nut 2 × M6 (Figure 3)

- Galvanised
- VE 25 units
- for all except PT/RE 40, 65

Part no.: 209021 0003

Special angle sliding nut

3 x M6 (Figure 4)

- Galvanised
- VE 25 units
- for all except PT/RE 40, 65

Part no.: 209022 0003

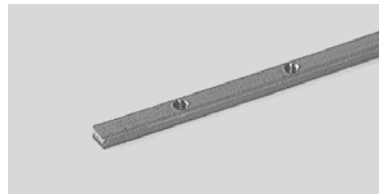

M6 tapped rail

- 10 x 4 mm
- Galvanised
- M6 Ra 50 mm
- VE 3 units at 1 m
- for all except PT/RE 40, 65/SP

Part no.: 209011



Plastic hinge strip

- L 65 × W 40
- VE 10 units and fixing
- Ra 43 × 20 mm
- for PL

Part no.: 209050 0012

Aluminium hinge strip

- L 40 × W 40 mm
- VE 10 units and fixing
- Ra 25 × 25 mm
- for all except PT/RE 40, 65

Part no.: 209050 0011

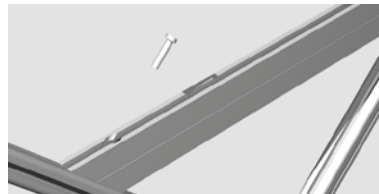

Cross-braces

- made from PP 50
- L 490 mm
- Mitred
- M6 drillings
- for all except PT/RE 40, 65

Part no.: 209300 0000

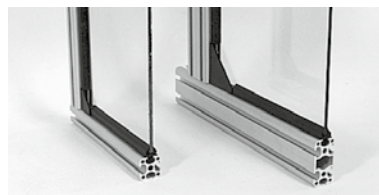

Black edging strip

- black, 1-part
- for plate thicknesses 3 - 4 mm
- VE 10 m

Part no.: 209202 0002 (PU-profiles)

Part no.: 209202 0001 (PP- and PS-profiles)



Accessories | for pillar and panel profiles (PP, PU, PL and PS)



Profile connection cubes

- black
- VE 10 units and fixing material
- for PU 25

2-fold | Part no.: 209104 0002

3-fold | Part no.: 209103 0002

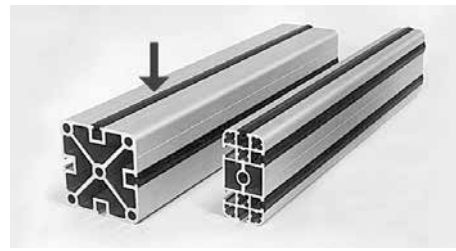

T-slot cover

- VE 30 m
- (turquoise = similar to RAL 5018)
- for all except PT/RE 40, 65

black | Part no.: 209201 0004

turquoise | Part no.: 209201 0003

light grey | Part no.: 209201 0007

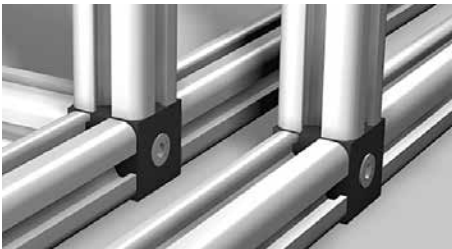

Profile connection cubes

- black
- VE 10 units and fixing material
- for PU 25

3-fold | Part no.: 209106 0002

4-fold | Part no.: 209107 0002

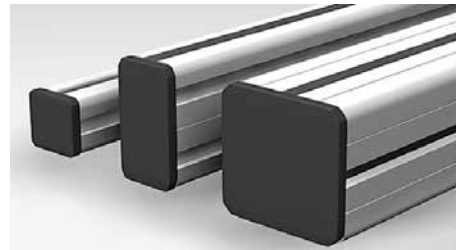

Profile covers

- black

PU 25 - 25 Units | Part no.: 209105 0003

PU 50 - 25 Units | Part no.: 209126 0003

PL 40 - 20 Units | Part no.: 209127 0003

PL 80 - 20 Units | Part no.: 209128 0003

PS 50 - 25 Units | Part no.: 209129 0003

PS 80 - 20 Units | Part no.: 209130 0003

PS 140 - 10 Units | Part no.: 209130 1001



Profile connection cubes

- black
- VE 10 units and fixing material
- for PU 25

4-fold | Part no.: 209108 0002

5-fold | Part no.: 209109 0002

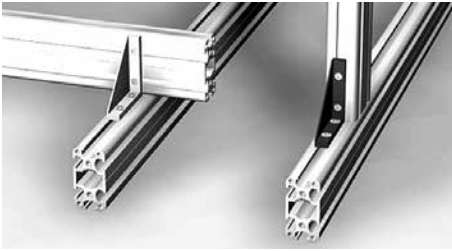

Aluminium corner connector

- L 25 × W 25 × H 15 mm
- VE 10 units and fixing material
- for PL, PS, PU, PP

natural | Part no.: 209114 0101

black | Part no.: 209114 0111

- L 40 × W 40 × H 22 mm
- VE 10 units and fixing material
- for PP/PL/PS/PU

natural | Part no.: 209115 0101

black | Part no.: 209115 0111

- L 50 × W 50 × H 15
- VE 10 units and fixing material
- for RE/PU/PS

natural | Part no.: 209116 0101

black | Part no.: 209116 0111

- L 80 × W 80 × H 22
- VE 10 units and fixing material
- For PP/PL/PS/PU

natural | Part no.: 209117 0101

black | Part no.: 209117 0111



Rubber-tired guide rollers

- Ø 75 (M10)
- VE 4 units
- 2 with and 2 without locking device
- for PL 40/PS 50

Part no.: 209043 0011



Plastic equipment bases

- with rubber plate
- VE 4 units and setting screws
- black

for PL 40 / PS 50

- Ø 60
- M10 × 50 setting screws

Part no.: 209032 0003

for PL 80 / PS 80

- Ø 80
- M12 × 50 setting screws

Part no.: 209034 0001

for PL 80 / PS 80

- Ø 120
- Setting screws M12 × 50

Part no.: 209033 0003



Aluminium equipment bases

- with rubber plate

for PU 50

- VE 4 units, with setting screws and reducing bushings
- Ø 50
- M6 × 30 setting screws
- natural

Part no.: 209030 0000

for PS 100 / 140

- Ø 170
- M16 × 100 setting screws
- black

Part no.: 209035 0001

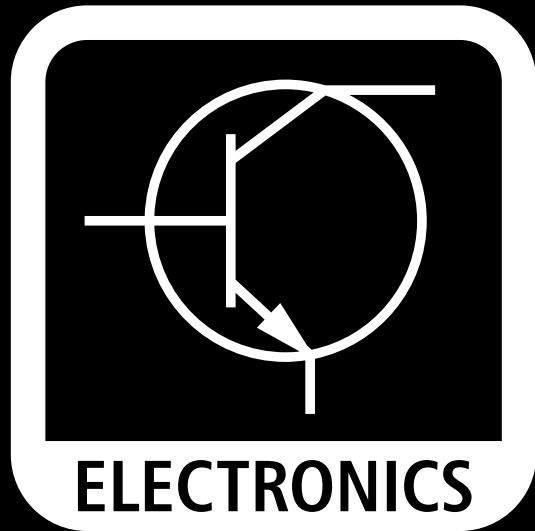

CNC control panel

CNC control unit iOP-19-TFT / iOP-19-CPU 118

CNC controller

Step controller IT 116 Flash..... 119

Step controller type iMC-S8 120

Single-axis MC1-20/40 controller 121

Power Unit type iPU-DC / iPU-EC..... 122

Multi-axis controller type iCU-DC / iCU-EC..... 123

Drive controller(s)

Drive controller iMD 20 and iMD 40 124

isel[®]

 *successful with
CNC TECHNOLOGY*



CNC control unit iOP-19-TFT / iOP-19-CPU

- Sturdy aluminium housing (standard colour: RAL 7035)
- 19" touchscreen display
- Easy mounting for the keyboard
- User-friendly alignment through the height-adjustable swivel arm
- Simple installation through VESA holder 100/100
- 3 USB ports

Features of the iOP-19-TFT

- Degree of protection according to IP 50
- Dimensions (without keyboard): W 480 x D 123 x H 450 mm
- Weight: approx. 15 kg

Features of the iOP-19 CPU

- Degree of protection according to IP 40 and IP 50
- Motherboard 64 bit / CPU IntelCore I3
- In addition, a network connection (LAN)
- Dimensions (without the keyboard): W 480 x D 196 x H 450 mm
- Weight: approx. 16 kg



The **CNC control units iOP-19** are a revised version of the previous person of the iBP control panel by isel. All experiences were incorporated into the new development of the model iOP-19. They have an integrated touch screen monitor of 19", a silicone keyboard and a control panel equipped with stainless steel buttons and emergency stop switch. A PC can be connected and operated with the model iOP-19-TFT through the standard connecting cables. The iOP-19 CPU is equipped with the isel CAN.

Options

- Simple keyboard and mouse tray
- High-quality mounting keyboard made of silicone (protection: IP68) - in German as well as English- 105 keys, with touchpad
- Stand foot
- Two-hand operation
- RAL 9005 (deep black) or anthracite hammering

Dimensional drawings

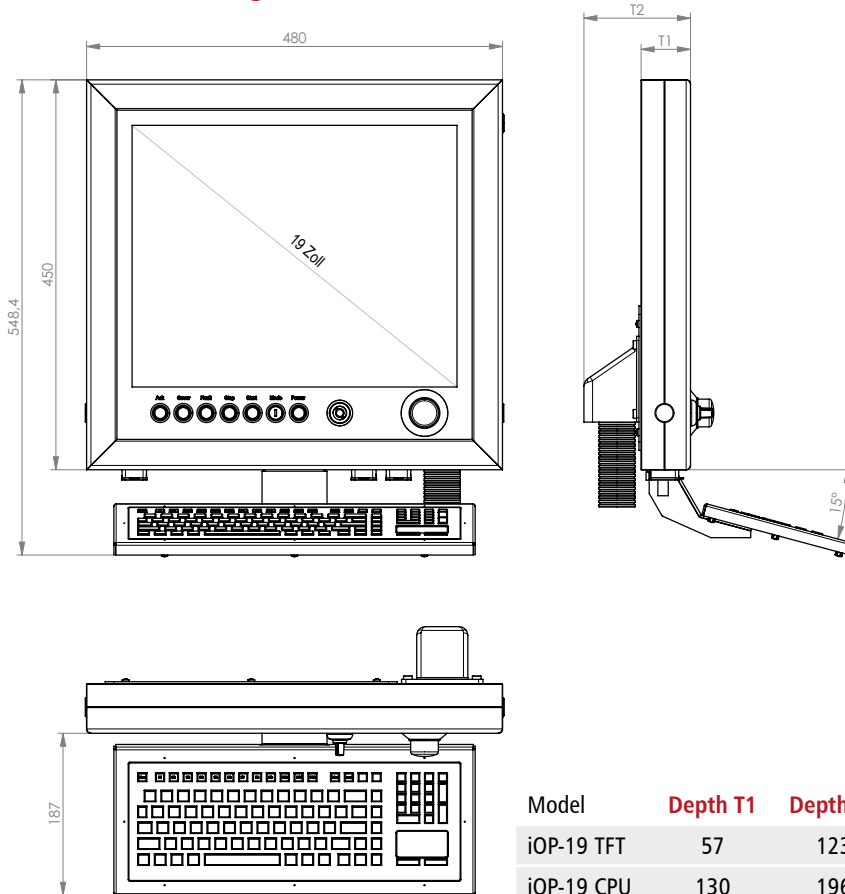

Order data

Control panel model iOP-19-TFT, colour RAL 7035
Part No.: **371100 6000**

Control panel model iOP-19-CPU, colour RAL 7035
Part No.: **371105 00070**

German keyboard, colour RAL 7035
Part No.: **371200 0007**

English keyboard, colour RAL 7035
Part No.: **371200 0008**

Swivel arm for the profile PS 50
Part No.: **371050 2020**

Swivel arm for the profile PS 80
Part No.: **371050 2040**

Swivel arm for the profile PS 100
Part No.: **371050 2050**

Swivel arm for the profile PS 125
Part No.: **371050 2060**

Swivel arm for the profile PS 140
Part No.: **371050 2070**

Swivel arm for profile PV 150
Part No.: **371050 2080**



Step controller IT 116 Flash

Single-axis controller



The step controller model IT 116 Flash is a freely programmable compact controller for a linear or rotary axis equipped with a 2-phase stepping motor. The step controller consists of an intelligent stepping motor output stage, a processor core with flash memory for the download and/or storage of the PAL-PC user program and the clock/direction signal generation for the motor output stage, the required power supplies, a safety circuit (stop category 0 according to the standard EN 60204), as well as a housing equipped with mains input filter and with operating elements.

The integrated operating system in the flash memory of the processor core supports both the

- DNC mode of the controller: PC/laptop permanently connected to the step controller through the serial interface

as well as the

- CNC mode of the controller: The step controller independently executes the stored user program without any PC coupling (as stand alone).

Order information

Step controller model IT 116 Flash (115VAC, 60 Hz)

Part No. **381016 0115***

Step controller model IT 116 Flash (230 VAC, 50 Hz)

Part No. **381016***

*including PAL-PC

Accessories

Motor cable type M23 12-pole Socket - SubD 9-pole Pin

Part No.: **392755 0500** (5 m)

Motor cable SubD 9-pole Socket - Plug 1:1

Part No.: **392781 0500**

Other length upon request.

- Poweroutput stage48 VDC / 4.2A peak for 2-phase stepper motors
- max. 25,600 microsteps / revolution
- Mains voltage: 115 VAC / 230 VAC, 50...60 Hz
- Automatic current reduction to 50% phase current at motor speed < 1 rpm
- Motor current /microstep resolution adjustable with dip switch
- Integrated 32-bit embedded controller (RISC) processor with flash memory for firmware as well as PAL-PC userprogram
- RS-232 interface (front) for coupling with PC /notebook (download of the program)
- Control signals: program start /stop, reset on rear of controller
- 4 opto-isolated signal inputs (signal voltage: 24VDC)
- 4 relay outputs (24VDC, 300mA)
- Control of the motor brake (24 VDC)
- Remote rear controller connector for the external EMERGENCY STOP (2-channel), external power on
- Euro fin housing
- Programming with PAL-PC 2.1 for Win2000, XP, Vista, 7
- Dimensions: W 105 x H 111 x D 320 mm

Scope of delivery

- Controller in cassette housing
- Counter connector (I/O, pulses, remote)
- Serial interface cable (SubD9 - RJ 45)
- Power cord type 230 VAC
- Software CD PAL-PC
- Operating instructions
- Programming instructions

Step controller type iMC-S8

Multi-axis controller



Step controller iMC-S8 as desktop version and with 19" housing

- 32-bit RISC processor equipped with flash memory for user program
- Power output stage
 - Step resolution and motor current which can be adjusted through DIP switch
 - Automatic current reduction
- Acceleration, start-stop frequency and step output frequency which are all adjustable
- Both hardware limit switches may be configured
- Door and/or hood control
- External EMERGENCY STOP and POWER connection for integration into higher-level safety circuits
- Connection for external control signals such as e.g.e START, STOP and RESET (CNC mode only)
- Programming/operation
 - PALPC in CNC mode (included)
 - remote (optional: ProNC) in DNC mode
 - by isel @ - format in CNC/DNC mode

The step controller model **iMC-S8** is a freely programmable compact controller for linear and rotary axes equipped with 2-phase stepping motors. The controller integrates all required components (power supply, safety circuit, power electronics, core processor, interfaces, as well as operating elements), which are required for the control of the single axes up to the complete machine. The said controller is equipped with an intelligent core module, which can be controlled or programmed through an RS232 interface. The core module converts the commands programmed within the user program into clock/direction signals for the connected output stages. According to the used application, the controller type iMC-S8 may be used either in the context of a CNC or DNC operation. In the CNC mode, the processor carries out the CNC program previously created with PAL.PC and then stored within the flash memory the controller is equipped with. In the DNC operating mode, the controller type iMC-S8 is constantly connected to a control computer (PC or laptop) through a serial interface (type RS232). The processing is carried out through the remote control software of the company isel.

Technical data

- 230V connection for the milling spindle (100-230VAC)
- 0 .. 10V analog output for the external frequency converter for the main spindle equipped with a speed control
- Wide range mains input between 100 and 250 VAC, 50..60 Hz
- Processor
 - equipped with flash memory of 128kB, 350 commands may be stored- maximum Step output frequency amounting to 40 kHz
- Power amplifier
 - supply voltage: 48 VDC- Peak
 - current: between 1.0 and 4.2 A (MD 24) between 2.8 and 7.8 A (MD 28)
 - Step resolution: from 400 to 51200 steps
- Inputs/Outputs- 16 inputs (24VDC)
 - 16 outputs (24VDC/300mA, IGeS 2A)
 - 1 relay output (230VAC, maximum 6A)
 - 1 analog output (between 0 and 10V)
- Operating/programming interface type RS232
- Stop category number 1, safety category number 2
- Variants:
 - Desktop housing W 475 x D 410 x H 187.5 mm
 - 19" housing W 482.5 x D 410 x H 177 mm

Order key

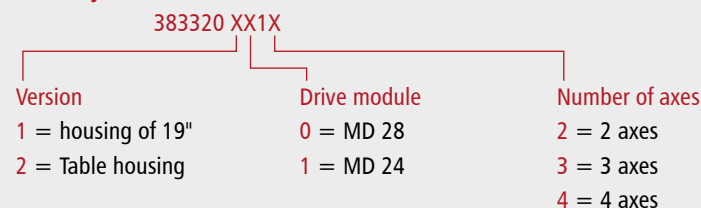

Scope of delivery

Controller, mating connector (I/O, impulse, remote), serial interface cable (null modem), power cable of 230 VAC, software CD type PAL-PC, operating as well as programming instructions

Accessories

- Motor cable M23 plug - M23 socket
Part No.: 392750 0300 (3m)
Part No.: 392750 0500 (5m)
- Motor cable M23 plug - SubD9 socket
Part No.: 392752 0300 (3m)
Part No.: 392752 0500 (5m)
- USB-RS232 Converter,
Part No.: 372000 0001
- Remote control software
Part No.: Z12-334500
- Control and programming software ProNC
Part No.: Z11-333500



Single-axis MC1-20/40 controller

iMD single-axis controller for the isel linear units

MC1-20

- For controlling brushless servo motors reaching an intermediate circuit voltage of 48 V DC

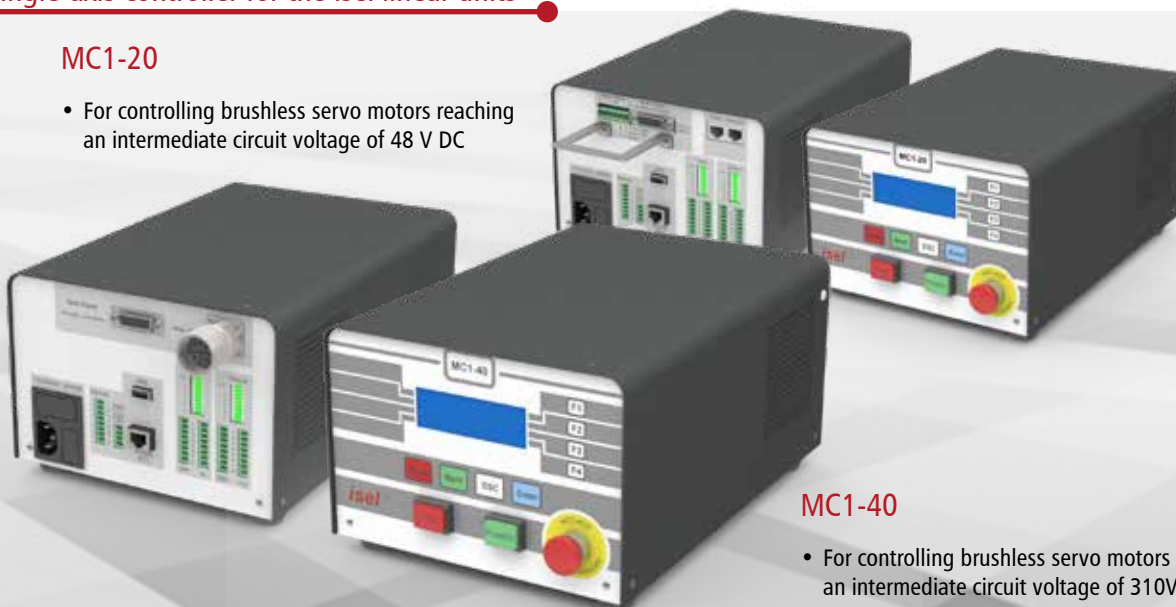

MC1-40

- For controlling brushless servo motors reaching an intermediate circuit voltage of 310V DC

The **servo controllers of the MC1 series** are freely programmable compact controllers for a linear or rotary unit equipped with a servo motor. The single-axe controllers integrate all required components (interfaces, motion controllers, power supply, drive controller, safety circuit, as well as operating elements), which are required for the control of an axis within a compact table housing. The supplied software PAL-PC may be used in order to carry out the programming.

The MC1 model is available in two variants:

- MC1-20: For the control of brushless EC servomotors (48 V)
- MC1-40: For the control of brushless EC servo motors (310 V)

Order information

MC 1-20 (including PAL-PC) Part No.: **381518 0020**
 MC 1-40 (including PAL-PC) Part No.: **381518 0040**

Motor cable MC 1-20 Part No.: **392760 xxxx***
 Motor cable MC 1-40 Part No.: **392307 xxxx***

Encoder line Part No.: **392740 xxxx***

*Cables available in various lengths,

e.g.: 0100 = 1m / 0150 = 1.5m / 0200 = 2m ... / 1000 = 10m

Common features

- Assessment of the Hall signals
- Commissioning program "AcSetup"
- Output power max. 500 W (MC1-20)
- 32-bit high-performance RISC processor with 256 KByte flash
- User program in CNC mode for up to 650 commands
- Program execution in CNC or in DNC mode
- Programming with PAL-PC (CNC mode), @-Format (CNC mode), ProNC, Remote (DNC mode)
- LC display including 4 lines of 20 characters per line (freely programmable)
- Additional control signals (start, stop) which can be adapted
- Connection for the incremental encoder
- 6 (8) signal inputs (of 24 V DC)
- 8 relay outputs (of 24V DC / 700 mA)
- Stop category 0 according to the standard EN60204
- An emergency stop circuit may be integrated into the higher-level safety circuits through plug connectors
- Wide range mains input:
MC1-20: 110...250 V AC, 50..60 Hz
MC1-40: 250 V AC, 50 Hz
- Table housing W 204 x H 149 x T286

Scope of delivery

- Controller
- Counter connector (I/O, pulses, remote)
- Serial interface cable (SubD9 - RJ 45)
- Power cord type 230 VAC
- Software CD PAL-PC
- Operating instructions
- Programming instructions

Power Unit type iPU-DC / iPU-EC

Multi-axis controller



Power Unit iPU as desktop version and with 19" housing

- Drive control for up to four brushed or brushless DC servomotors
- NC control carried out by the fieldbus CANopen
- Power output stages iMD10 / iMD20- 4-quadrant drive
 - controller- evaluation for incremental
 - encoder-standstill monitoring-over- and under-voltage as well as
 - over-temperature protection, short-circuit-proof
- Door and/or hood control
- Connection for the external control signals such as for example the EMERGENCY STOP, START, STOP to permit the integration into higher-level safety circuits
- Connection for the milling spindle (between 100 and 230VAC)
- Control elements positioned inside the front part of the housing (optional on the rear)
- Programming and/or remote operation (optional: ProNC)

The **Power Units iPU** are powerful drive controls for up to four linear or rotary axes equipped with brushed or brushless motors. The compact controller integrates all the required control components needed to execute different tasks relating to automation. These range from the power output stages of the types iMD10 or iMD20 through the I/O module to the safety control and power electronics.

As an interface for NC control, the **Power Unit iPU** has an interface of the type CANopen positioned on the rear side of the housing and working according to the bus protocol DS301 and DS402. By using the optional CAN PCI card iCC 10 or a control computer of the iPC series, the controller allows the (linear, circular, as well as helical) interpolation of all four axes as well as web processing.

In addition, the power output stages used (the type iMD10 or the type iMD20) have an automatic jerk limitation and standstill monitoring. The control elements integrated into the front part of the housing, such as the EMERGENCY STOP and the START or STOP, enable convenient operation.



Technical data

- 0 .. 10V output for the external frequency converter used for the main spindle equipped with a speed control
- Wide-range mains input
 - 115VAC/230VAC, 50..60 Hz
- Switching power supply of 1000W/48V
- Power output stages iMD10/iMD20
 - Supply voltage: 24- 80VDC
 - Peak and/or rated current: 25A / 12A
- Inputs/Outputs
 - 4 digital inputs (24VDC /8mA)
 - 8 digital outputs (24VDC / 350mA)
 - 1 relay output (230VAC, max. 6A)
 - 1 analog output (between 0 and 10V)
- Safety control
 - up to the safety category number
 - 3-Door circuit
 - control- Spindle control
- Interface type RJ 45 CANopen
- Variants:
 - Desktop housing: W 475 x D 410 x H 232 mm
 - 19" housing: W 482.5 x D 410 x H 221 mm

Order key

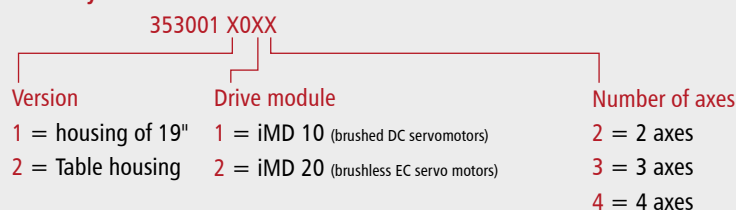

Scope of delivery

Controller, mating connector (I/O, impulse, remote), can bus line (type RJ45, patch cable), power cable of 230 VAC, operating instructions

Accessories

- Motor cable M23 plug - M23 socket
 - Part No.: 392759 0300 (3m)
 - Part No.: 392759 0500 (5 m)
- Encoder cable equipped with the plug SubD15 and the socket SubD15
 - Part No.: 392740 0300 (3 m)
 - Part No.: 392740 0500 (5 m)
- CAN-PCI card type iCC 10 (1 channel) Part No.: 320320
- CAN-PCI card type iCC 20 (2 channels) Part No.: 320311
- Remote control software Part No.: Z12-334500
- Control software ProNC Part No.: Z11-333500



Multi-axis controller type iCU-DC / iCU-EC

iMD Multi-axis Controller for the linear units of isel



- Drive control for up to six brushed or brushless DC servomotors
- NC control carried out by the fieldbus CANopen
- Power output stages iMD10/iMD20
 - 4-quadrant drive
 - controller- evaluation for incremental
 - encoder-standstill monitoring-over- and under-voltage as well as
 - over-temperature protection, short-circuit-proof
- Door and/or hood control
- External EMERGENCY STOP for the integration into higher-level safety circuits
- Connection for external control signals such as START, STOP, RESET through signal inputs
- Connection for the milling spindle (between 100 and 230V AC)
- Industrial control computer based on Windows® with
 - PCI card type CANopen
 - driver software for the CNC control
- Programming and/or remote operation (optional: ProNC)

The **can controllers** of the **iCU-DC** and **iCU-EC** series are compact and powerful drive controllers for 2 to 6 DC servomotors offering an ideal price/performance ratio.

The table housing integrates all control components you need to execute a wide variety of tasks when it comes to automation. These range from the output stage through the I/O module to the safety control.

A PCI card of the type CANopen is integrated in the control computer and as an interface and serves as a CANMaster for the drive controller and for the I/O module. Furthermore, the external extensions to up to 128 can nodes are easily feasible. Among other things, the rear connections of the control computer enable the simple monitor connection. Thanks to the existing USB interfaces, you can connect different peripheral devices such as your mouse and your keyboard. A LAN connection allows the integration into an existing network and can be used for remote maintenance as well.

The NC control core enables the interpolation of up to 6 (linear, circular as well as helical) axis by additionally offering an online and look-ahead web processing. When using the ProNC software, the individual axes can be controlled as handling axes (in addition to the interpolating axes).

All power amplifiers are equipped with an automatic jerk limitation and a standstill monitoring (up to the safety category number 3).

Technical data

- Control computer connections: VGA, 4 x USB (2 x front, 2 x rear), RJ45 Ethernet (100 Mbit/s)
- 0...10V output for the external frequency converter used for the main spindle equipped with a speed control
- Wide-range mains input of 115 V AC / 230 V AC, 50...60 Hz
- Switching power supply 1000 W / 48 V
- Power output stages iMD10 / iMD20
 - Supply voltage: 24...80 V DC
 - peak/rated current: 25 A / 12 A
- Inputs/outputs of the CAN I/O module
 - 4 digital inputs-8 digital outputs
 - 1 relay output (230 V AC, maximum 6 A)
 - 1 analog output (will not be applied if you opt for the frequency converter)
- CAN Safety circuit
 - module up to safety category
 - 3-Door circuit
 - control- Spindle control
- Table housing W 630 x H 230 x D 400 mm
- Options:
 - Frequency inverter for iSA500 - iSA2200
 - Additional CAN I/O module (16 x inputs, 16 x outputs)

Order key

	354012 X0X0	Number of axes
		2 = 2 axes
		3 = 3 axes
Version		4 = 4 axes
1 = iCU-DC (brushed DC servomotors)		5 = 5 axes
2 = iCU-EC* (brushless EC servo motors)		6 = 6 axes

Scope of delivery

Controller, mating connector (I/O, impulse, remote), power cord of 230 V AC, operating as well as programming instructions

Accessories

Motor cable M23 pin - M23 socket

Part No.: 392759 0300 (3m)

Part No.: 392759 0500 (5 m)

Encoder cable SubD 15 plug - SubD15 socket

Part No.: 392740 0300 (3 m)

Part No.: 392740 0500 (5 m)

Drive controller iMD 20 and iMD 40

For servo motors



General information

The **iMD 20** drive controller is one of the most proven and cost-effective output stages used for the EC servo motors. Our fully digital drive controller model **iMD40** is a power amplifier for EC servo motors (synchronous motors such as linear or torque motors) up to 2kW.

The typical applications for this driver controller are the CNC machines as well as the automation technology. The housings of the power amplifiers are optimized for their installation within the control cabinet. The extensive options in terms of parametrization permit the flexible adaptation to a wide variety of applications, and all required settings can be made by using a user-friendly commissioning software.

Various user interfaces are available for the integration into your own applications. The interface CANopen should be especially mentioned in this context. In addition to synchronous point-to-point positioning (S-PTP) and speed control, continuous path control (CP) and time-synchronized multi-axis applications may be implemented through the implemented protocol DS402 of the type CANopen. Additional interfaces are a $\pm 10V$ interface (speed set-point) and an interface of the type RS232

Short controller cycle times (current, speed, as well as position controllers) guarantee the ideal behaviour for highly dynamic drives. The drive controllers are suitable for both rotary as well as the corresponding linear direct drives and torque motors (types iMD20 and iMD40).

The redundant standstill monitoring has been integrated into the drive controllers. This permits the reduction of the effort in external modules of the control system to a minimum by making the use and/or the application of the machine comfortable.



Technical data	IMD 20	IMD 40
Motor type	Brushless servo motors (EC, BLDC)	Brushless servo motors (EC, BLDC)
Supply voltage	40 - 95 VDC	Network of 230 VAC, 1-phase
Motor current	Continuous current 12 A, peak current 25 A	Continuous current 6.5 A Peak current 8 A
Can bus interface	CANopen DS301 v4.0 and DS402 v1.0 of the CiA (CAN in Automation)	CANopen DS301 v4.0 and DS402 v1.0 of the CiA (CAN in Automation)
Interface of the type RS-232 (asynchronous, 19.2 or 57.6 kBit/sec.)	For commissioning (AcSetup.exe) or for example, PLC connection; Effective transmission protocol	For commissioning (AcSetup.exe) or for example PLC connection; effective transmission protocol
Measurement system	Incremental encoder (type RS422); Maximum input frequency: 1.25 MHz	Incremental encoder (type RS422); maximum Input frequency: 1.25 MHz
Commutation		Hall sensor signals
Analog input (± 10 V)		11 bit resolution
PWM switching frequency		maximum of 16.4 kHz
Inputs for end and reference switch	✓	✓
Digital power, speed and position control	Sampling times: at least $61\mu\text{s}/244\mu\text{s} / 488\mu\text{s}$ for current / speed / position controller	
Brake control	✓	✓
Gantry operation and/or Synchronous control	From 2 modules, master-slave through the CAN bus	
Monitoring of the motor current	Short ^{circuit} , I _{2t} , pulse-by-pulse	
Monitoring of the encoder signals	✓	✓
Monitoring of the software by the internal watchdog timer	✓	✓
Facilitated update of the firmware through RS-232	Feasible on site by the customer or by a service technician	
Standstill monitoring	Redundancy according to the ISO standard	
Dimensions	180 x 35 x 120 mm	180 x 50 x 150 mm
Part No. Drive controller(s)	314 030	314 040

Subject to technical changes.



Controlling

remoteNC 128

Automation

proNC 130

PAL-PC 132

Software extension module

OPC UA Server 134

CAD-CAM

isy-CAM 2.8 136

isy-CAM 3.6 137

Fusion 360™ 138

isel®

●●● successful with
CNC TECHNOLOGY



Control software remoteNC

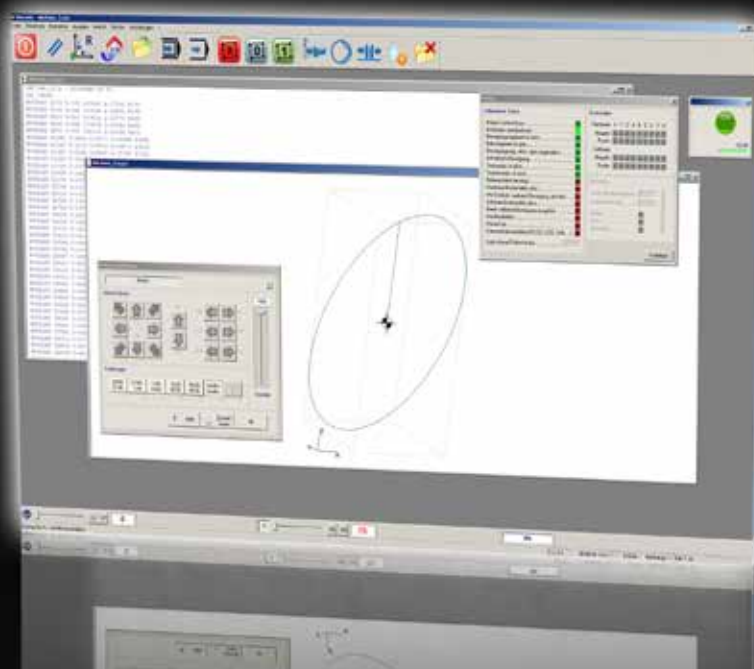

Function scope

- support of digital joysticks
- panel "Quick File Selection" for the batch production
- utility milling machines/multiple output with shifts
- graphic representation of the processing file with zero point and dimensions

File formats isel-NCP, DIN66025 / G-code

- linear, circular, and helix interpolation, and drilling cycles
- access to digital and analog inputs and outputs
- in case of the use of a CAN control: input/output "On-The-Fly" (without movement stop) for dispensing applications
- message window, messages in the status line, time delay, input of variable values
- definition and use of machine positions (workpiece zero point, parking position, home position...)

Additional functions for the isel-CNC file format (ProNC output format)

- repeating and counting loops,
- branches
- arithmetic and trigonometric functions
- subprogram technique
- integration of real and string variables
- loading and saving of process variables
- access to user-specific extensions, option of calling up user software

Features

- compatibility with earlier versions of the program
- processing of the file formats DIN66025 (G-code), NCP or CNC
- immediate processing without conversion, translation or transformation of the file
- integrated text editor with many functions for rapid corrections to the existing NC program
- use of up to 6 interpolating axes (cartesian coordinate system and 3 auxiliary axes)
- look-ahead path processing by means of CAN control
- management of a milling spindle
- 2 E/A units may be used (maximum of 64 inputs, 64 outputs)
- signalling inputs and outputs for the process synchronisation
- manual axis movement with joystick, keyboard, and mouse
- step-by-step processing and system monitoring for commissioning operations
- user interface, configurable for ease of use, series production, handshake equipped with master PLC...
- control panels for motion control, input/output, spindles, and tool change by means of buttons
- available in several languages (German, English, French, Hungarian)

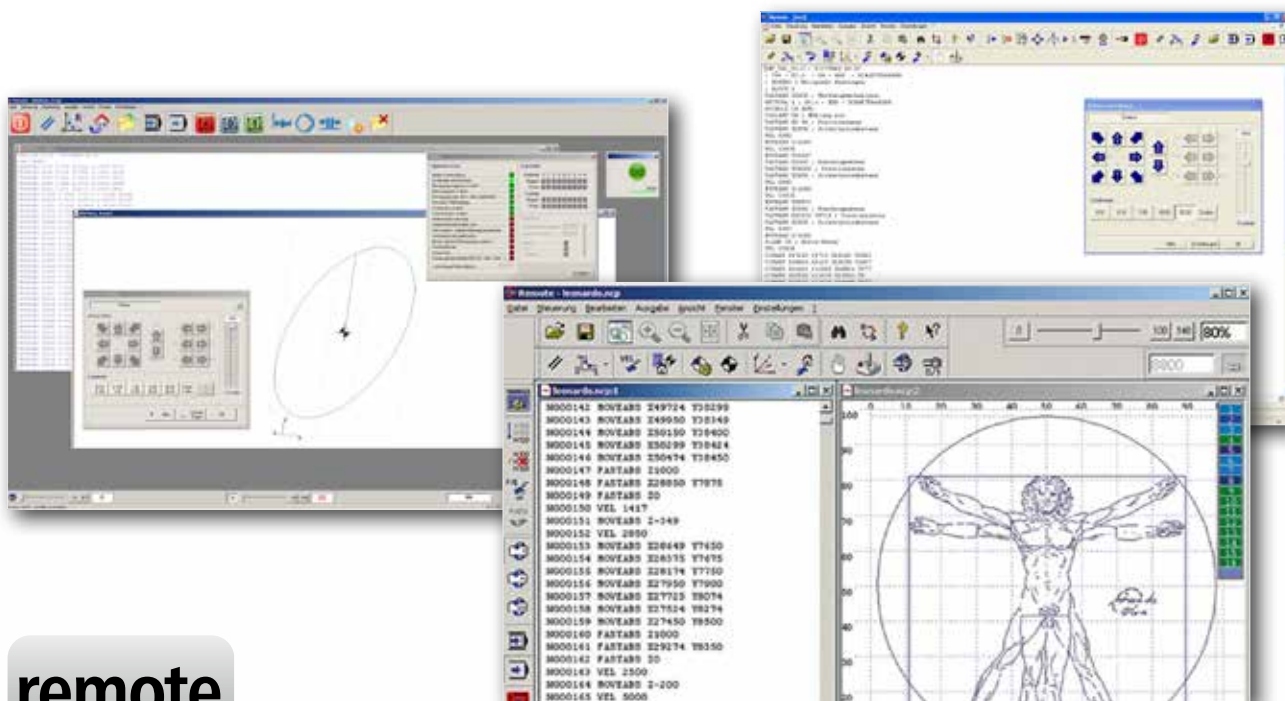

remoteNC is a universal control program for the output of files during the machining processes of milling, drilling, gluing, engraving, applying as well as in the field of water jet cutting or laser cutting/welding. Supported file formats are the isel-specific NCP format (ASCII file with machining data created by a CAM post-processor), the isel-specific CNC format (the ASCII files in an extended format

for universal use in the field of process automation, created by ProNC) as well as the G-code format in accordance with the standard DIN 66025. remoteNC is primarily used for the control of CNC machines for a wide variety of tasks and processing. This is why flexibility is a main feature of the program. A wide selection of options enables the simple adaptation to the respective requirements.

Control software remoteNC

- runs under Windows operating systems
- universal CNC control program for NCP files and G-code
- for additive and subtractive methods; water jet and laser cutting
- linear, circular, and helix interpolation, and drilling cycles
- configurable user interface for ease of use, series production, handshake equipped with master PLC
- look-ahead path processing by means of CAN control
- up to 6 interpolating axes may be controlled

Order data

Part No.

Software remoteNC for
CAN-CNC controls (Windows)

Z12-334500



Automation software proNC

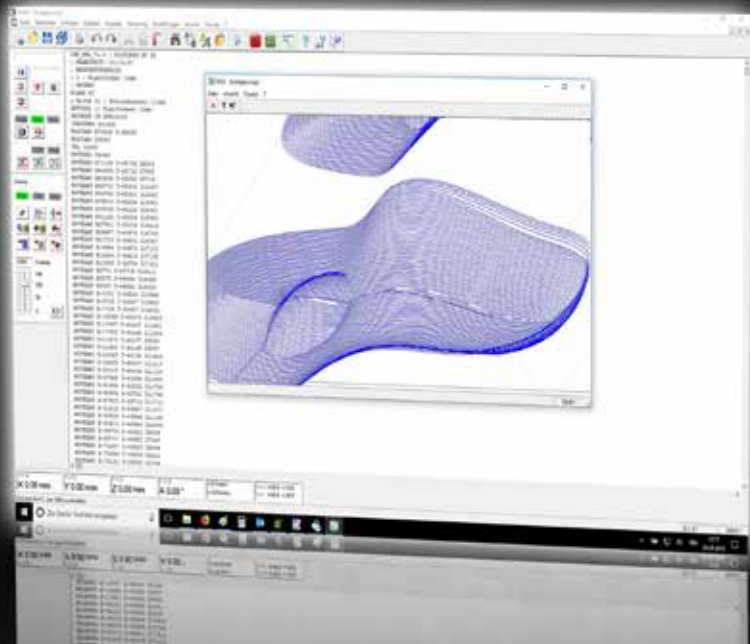

Function scope

- path commands for the relative and absolute positioning of the interpolating axes
- programming of additional axes in the handling mode
- circular and helix interpolation, and drilling cycles
- repeating and counting loops, and branches
- numerous math and trigonometric functions
- subroutine technology, and symbolic variable
- integration of real and string variables
- message window, messages in the status line
- loading and saving of process variables
- access to digital and analogue inputs and outputs
- "On-The-Fly" input/output (without movement stop) for dispensing applications
- access to the user-specific extension DLLs (Dynamic Link Libraries)
- comfortable debug support (breakpoints, monitoring for status and variables)

Features

- programming in accordance with the standard DIN66025 (G-codes) or isel-PAL
- compatibility with earlier program versions (ProDIN, ProPAL)
- integrated text editor with numerous functions for rapid and efficient editing of the source code
- import of geometry data (NCP, such as for example by isy-CAD/CAM)
- use of up to 6 interpolating axes and up to 6 handling axes (equipped with a CAN control)
- look-ahead path processing equipped with CAN control
- up to 4 spindle motors may be used
- up to 4 E/A units may be used (maximum of 64 inputs, 64 outputs)
- signalling inputs and outputs for the process synchronisation
- teach-in with joystick, keyboard, and mouse
- offline programming with simulation modules
- step-by-step processing, breakpoints, and system monitoring for commissioning operations
- may be individually expanded with software libraries
- control panels for motion control, input/output, spindles, and tool change by means of buttons
- control panel for a maximum of 6 handling axes independent of the interpolating axes
- available in the German and English language

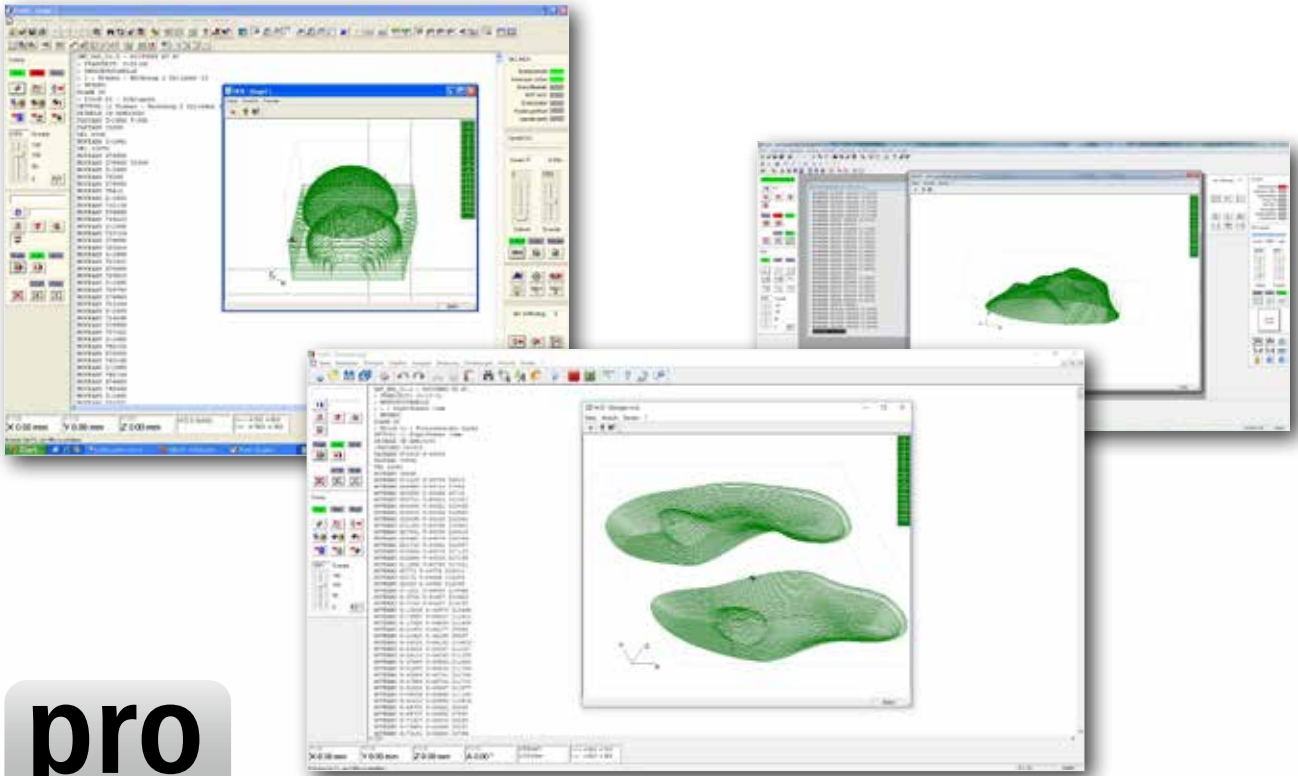

Every single automation solution is based on high-performance software, by means of which the tasks at hand can be rapidly and conveniently converted into a practical solution. In this context, the proNC operating and programming interface is the ideal solution.

Programming software proNC

- runs under Windows operating systems
- available for current controls and controllers by isel
- applications can be created in accordance with the isel-PAL or DIN66025 proNC is ideally suited for automation solutions in the fields of milling, drilling, standard dispensing applications, assembly, handling, loading and quality testing, where the user programs are predominantly textual using teach-in functions, as well as the import of contour data sets (such as for example NCP format).

Order data

Part No.

Software proNC for CAN-CNC controls (Windows)	Z11-333500
--	------------



Automation software PAL-PC

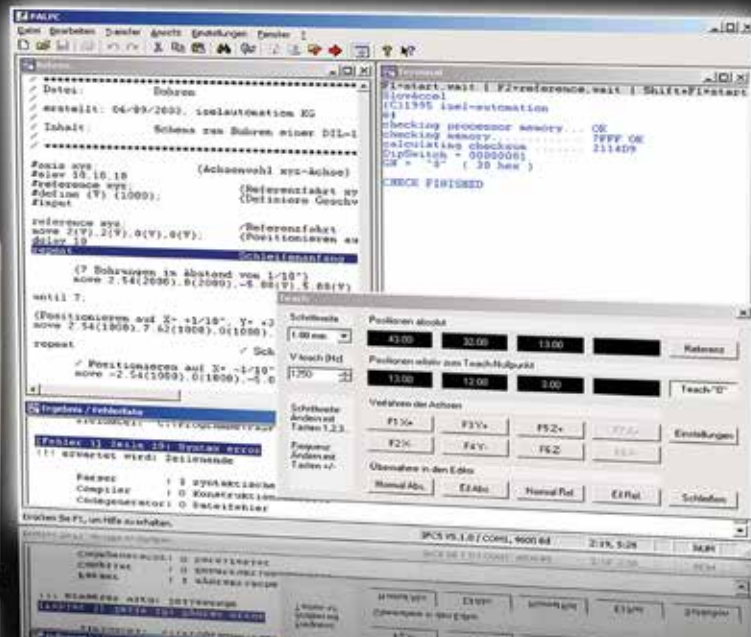

Function scope

- travel commands for relative and absolute positioning
- execution of the movement until an event occurs at an input
- (linear) teach-in programming
- linear 2D interpolation, switchable to 3D interpolation
- circular interpolation
- evaluation of input signals for the process control
- loops for the repetition of instruction blocks
- unconditional and conditional branches
- evaluation of the program selection unit
- output of messages on a display
- transmission and receipt of synchronisation characters
- additional tools for the automated processing of typical tasks

Program development environment for CNC stepper motor controller

- programming in accordance with isel-PAL
- 2D and 3D interpolation
- teach-in programming
- memory mode (CNC mode)
- operating systems Windows 32/64bit

Features

- compatible with previous versions (PAL-PC programs created with an earlier version of PAL-PC may be used without any adaptation)
- programming in accordance with isel-PAL
- integrated editor: rapid and comfortable editing of source texts, editor functions such as "search", "replace", "copy" and "paste", automated code generation, multiple undo/redo for efficient program creation
- the PAL-PC may (depending on the type of control in use) control controllers with up to 4 axes
- terminal for direct communication by means of the controller
- download of externally created CNC programs
- automatic determination of the type and transmission rate of the connected controller
- display of syntax errors and navigation to errors in the source code
- rapid overview of commands with optional insertion into the program
- teach-in programming by means of keyboard or mouse
- integration of the target positions as formatted source code into the editor
- live display of the current status at the inputs/outputs
- setting of outputs during program creation
- available in the German and English language

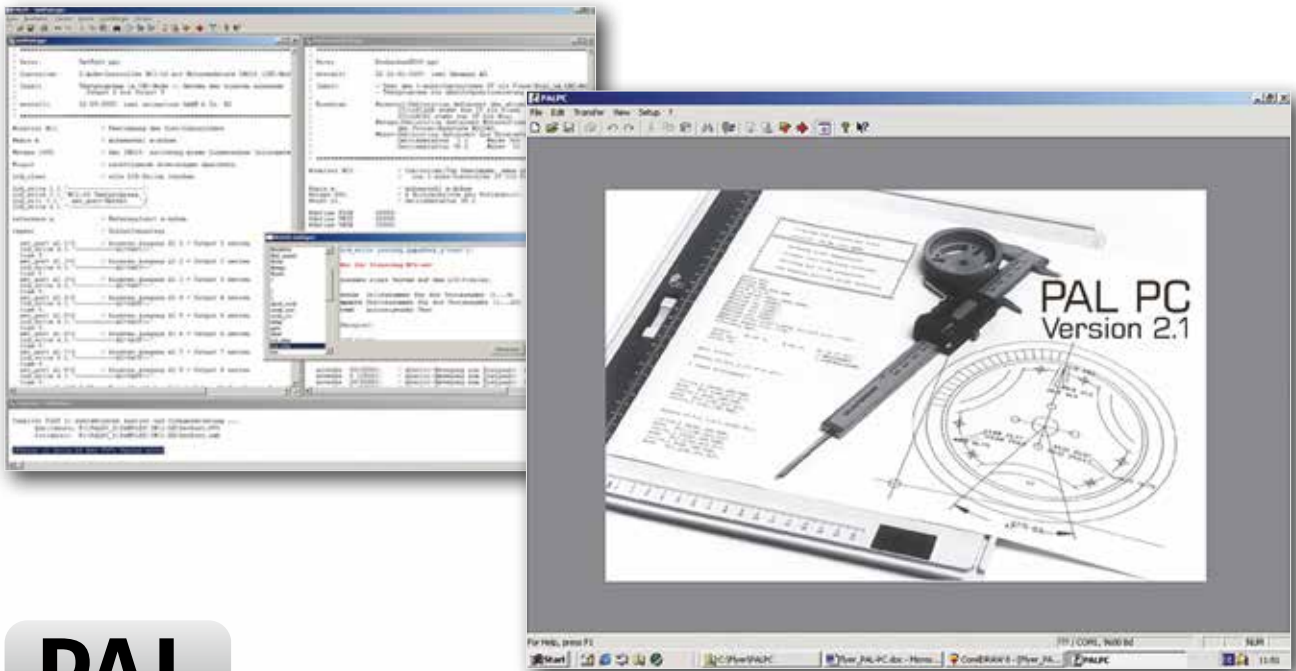

PAL-PC enables the rapid, simple, and inexpensive implementation of automation projects such as handling systems, automatic drilling machines, cycle devices, measuring and testing systems, automatic machines for individual and series processing and much more ...

Process automation software PAL-PC

- runs under Windows operating systems
- the PAL-PC is a modern program development environment for CNC stepper motor controllers and for CNC machines.
- the PAL-PC uses the memory mode (CNC mode) of the target controller. By means of the PAL-PC, automation solutions are created where the controller works in a stand-alone mode, i.e. independently of a control computer

Order data

Part No.

PAL-PC - software for
process automation
(Windows)

Z11-331810



Software extension module

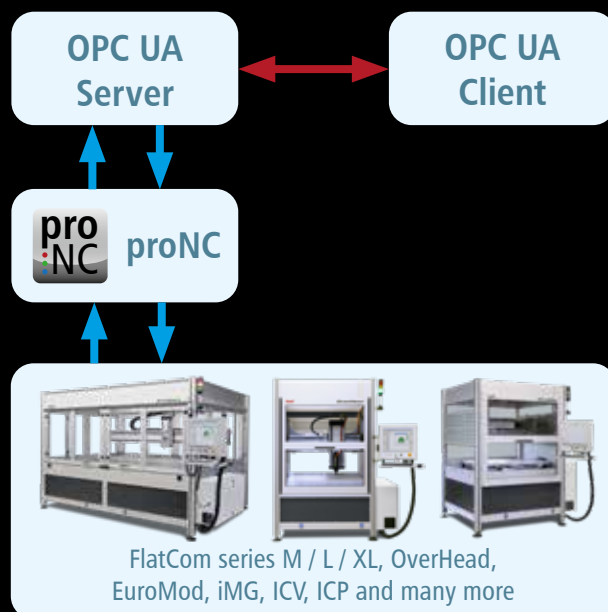

OPC UA (Open Platform Communication, Unified Architecture)

... is a communication protocol for Industrie 4.0 and the Internet of Things (IoT). This protocol enables standardized data exchange between machines, devices and components used in the industrial sector. The interface standard is independent of manufacturers or system suppliers of an application, of the programming language in which a software was programmed and of the operating system on which the OPC UA application is finally executed.

Features

- OPC UA software extension module for isel machines.
- recommended hardware: Intel Core i3/i5, AMD Ryzen 3/5 or higher
- runs under Windows operating systems
- connection of already existing systems and machines possible (update of ProNC may be required)
- integration of almost all machine models possible
- continuous expansion and supplementation of the information models provided
- compatible with common clients (more details on request)

Scope of functions

With a view to the usability of the isel machine series in an automation environment, useful functions from various information models were implemented in the isel OPC UA server application, which support the use of the machine by an OPC UA client. The functions provided enable the easy integration of almost all machine series offered by isel into OPC UA-based automation processes.

The following information models were implemented with the specified information:

- **Euomap 77**
Job management, machine configuration, machine information, machine status
- **Umati**
(universal machine technology interface)
Machine identification, machine monitoring (Machine-Tool), production information (ActiveProgram)
- **Manufacturer-specific isel**
Access to machine and control parameters, access to variables, reading and writing of digital and analog inputs and outputs, job management via flag signaling, querying of process data, and much more.





The image displays two screenshots of the Unified Automation software interface. The top screenshot shows a 'Data Access View' with a table of server nodes. The bottom screenshot shows a tree view of the OPC UA server structure, with a magnifying glass highlighting the 'CncAxisList' node.

Server	Node ID	Display Name	Value	DataType	Issue Timestamp	Statuscode
1
2
3
4
5
6
7
8
9
10
11
12
13
14
15
16
17
18
19
20
21
22
23
24
25
26
27
28
29
30

Screenshots of uaExpert™
© Unified Automation GmbH

```

File: C:\CNCWorkbench_D\Tools\CncWbOpcUaSvc\CncWbOpcUaSvc.exe
-----
File: Isel CncWorkbench OPC UA Server
Version: 8.9.1.8 - Mar 4 2021
SWM Version: 1.7.3.0/9 / d4d418907328431c82e4a0225f3837c0ff6fca
Info: OPC UA Server for Isel cnc machines.
-----
Copyright (C) 2019-2021 Isel Germany AG. All rights reserved.
-----
For MRO-URLs click with Isel Firm Code and
CNC ID User Code found at any part
-----
Demo-Mode started.
The server will be closed in 30 minutes.
-----
Server opened endpoints for following URLs:
opc.tcp://OPC5KTOP-U3PWRM1-48016
-----
Press x to shut down server
-----
    
```

Order data

Part No.

OPC UA
Software extension module
for Isel machines

z11-333500-0002



CAD-CAM software

isy-CAM 2.8

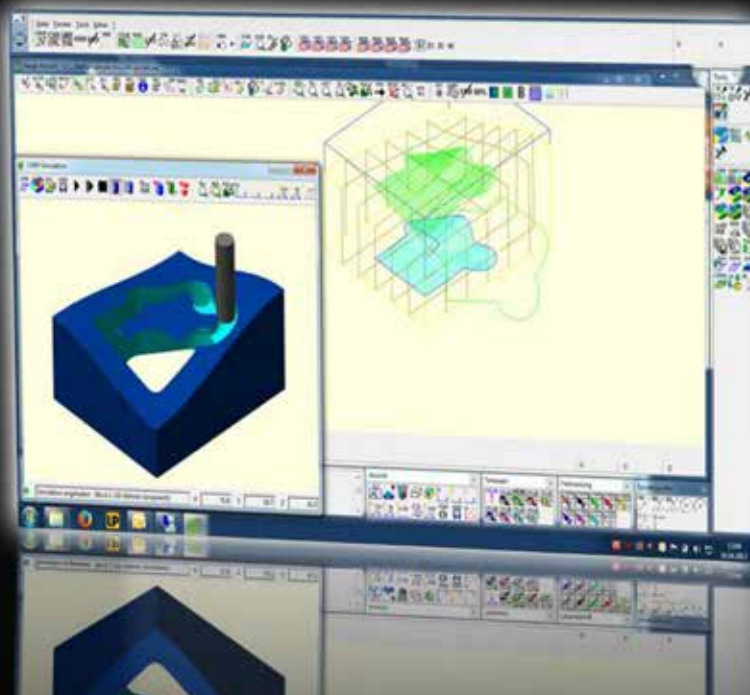

Function scope

- MultiCore support
- dynamic rotating simulation
- freely definable line types and colours
- integrated online support and configurable user interface
- parallel and independent work on several drawings
- geometrical elements such as points, lines, ellipses, circles, curves (polygons, splines, Bézier curves, NURBS), polygons and much more.
- direct use of Windows fonts
- professional number and text editing functions
- hatching, and freely definable hatching types
- automatic arrangement and alignment functions
- sketch contours and their interactive modification
- numerical input options for absolute, relative, and polar coordinates
- extensive DIN/ISO-compliant measuring and dimensioning functions
- trimming, separating and drawing curves, converting various geometry types
- geometry manipulation by moving and copying as translation, rotation, scaling, and mirroring
- smart object snap
- ideal control of the calculated NCP data through integrated online simulation of the tool paths
- generation of machining data for all typical 2D and 2.5D manufacturing tasks
- output format: NCP format

Features of isy-CAM 2.8 and 3.6

- CAD functionalities (without volume modeller)
- runs under Windows operating systems
- import: DXF / EPS / AI / 3D-STL data
- export: NCP format
- proven CAM strategies for drilling / contour / pocket milling
- engraving with gouge
- 4-axis cylinder machining
- 3D roughing and finishing of STL data (for example, scan models in 3D)
- direct call of REMOTE from the isy-CAM

Order data

Part No.

isy CAM 2.8 - basic version	Z13-337070
Update to isy CAM 2.8	Z13-337070-0001
Basic version with training	Z13-337070-0002
Second license for isy CAM 2.8	Z13-337070-0003



CAD-CAM software

isy-CAM 3.6

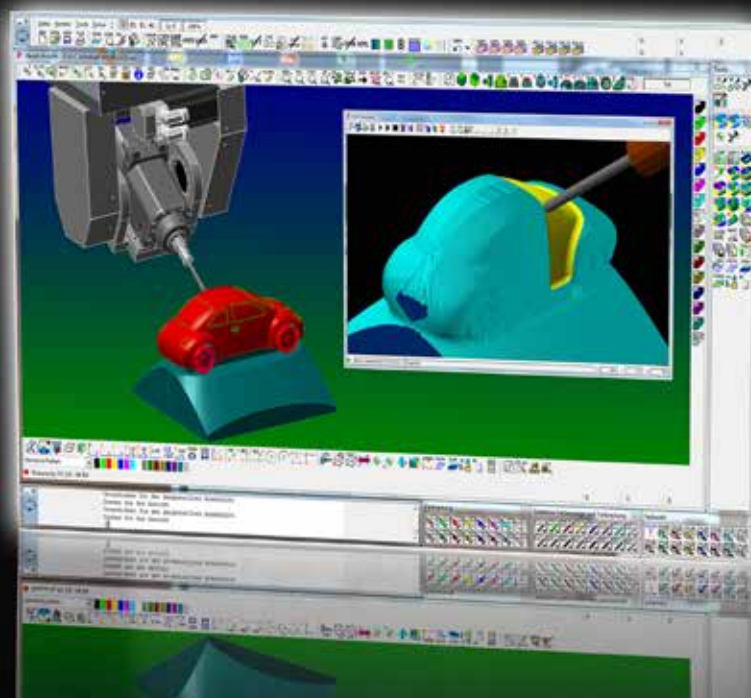

Function scope

- MultiCore support
- dynamic rotating simulation
- freely definable line types and colours
- integrated online support and configurable user interface
- parallel and independent work on several drawings
- geometrical elements such as points, lines, ellipses, circles, curves (polygons, splines, Bézier curves, NURBS), polygons and much more.
- direct use of Windows fonts
- professional number and text editing functions
- hatching, and freely definable hatching types
- automatic arrangement and alignment functions
- sketch contours and their interactive modification
- numerical input options for absolute, relative and polar coordinates
- extensive DIN/ISO-compliant measuring and dimensioning functions
- trimming, separating and drawing curves, converting various geometry types
- geometry manipulation by moving and copying as translation, rotation, scaling, and mirroring
- smart object snap
- ideal control of the calculated NCP data through integrated online simulation of the tool paths
- generation of machining data for all typical 2D and 2.5D manufacturing tasks
- output format: NCP format features
- extended mesh manipulation
- version of 32/64 bit
- hybrid milling (steep and flat areas in the course of one work step)
- trochoidal milling
- improved residual material detection and processing
- multi-sided machining (3+2 axes, inclined milling)
- expandable to 5 simultaneously movable axes

System requirement isy-CAM 3.6

- intel Quad Core i5, i7 or i9 processor (or comparable)
- runs under Windows operating systems
- 8GB RAM
- NVIDIA graphics card (e.g. GeForce GTX 1060)
- sufficiently large monitor

Order data

Part No.

isy CAM 3.6 - basic version with training for 1 person	Z13-337071
Update from 2.0 / 2.5 / 2.5 plus to isy CAM 3.6 without training	Z13-337071-0001
Update from 3.0 / 3.2 to isy CAM 3.6 without training	Z13-337071-0002
Update from 3.4 to isy CAM 3.6 without training	Z13-337071-0003
Update from 2.8 to isy CAM 3.6 without training	Z13-337071-0004
Second license for isy CAM 3.6	Z13-337071-0005

Exchange Package

Part No.

Exchange Package 3.6 (IGES, VDA, STEP)	Z13-337071-0006
Exchange Package 2.0 to 3.6 (IGES, VDA, STEP)	Z13-337071-0007
Exchange Package 3.0 to 3.6 (IGES, VDA, STEP)	Z13-337071-0008
Exchange Package 3.2 / 3.4 to 3.6 (IGES, VDA, STEP)	Z13-337071-0009



AUTODESK® Fusion 360™

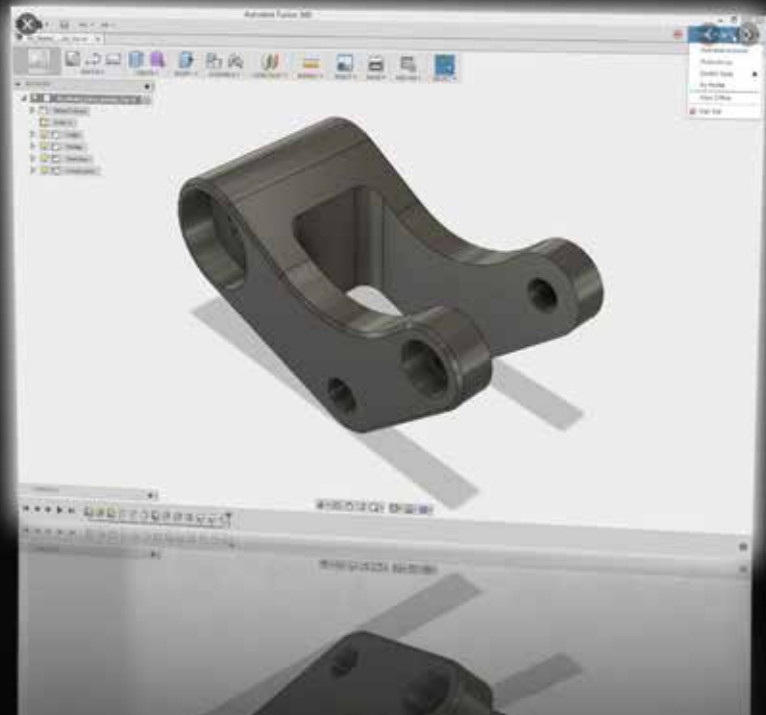

Autodesk HSM was particularly developed for the use with Autodesk® Inventor®/ SolidWorks®/ Fusion360™ and represents a logical addition to CAD software for the CAM sector. Experienced CAD users feel at home when working with Autodesk HSM and can create toolpaths of the highest quality-level within a couple of minutes. The new users benefit from the unsurpassed 2D and 3D functionalities of the CAD solution and can rapidly and easily expand the know-how acquired through the CAM process. The result consists of a qualitatively improved design and of shorter product development times.

Optimal toolpaths

The toolpath strategies by Autodesk HSM are designed for the generation of the smoothest and most efficient toolpath possible in order to reduce machining time, improve the surface quality, and reduce the wear level of the tools.

Function scope

- certified post-processor for isel CNC machines equipped with 3/4/5 axis
- the first cloud-based CAD/CAM solution of the world
- excellent 2D/3D CAD functionality
- very easy to use
- short processing times/reduced level of tool wear
- networking - communication - better cooperation

Try Fusion360™ for free

Are you a start-up entrepreneur with a yearly turnover under € 100,000 or you a leisure user?

Then you may possibly take advantage of a free usage.

Find out more directly from the Autodesk reseller, the company HSMTEC GmbH

Features

- excellent 2D/3D CAD functionality achieved through the combination with Autodesk® Fusion 360™
- consistency from the CAD model to the NC file
- very easy to use, resulting in extremely short training and familiarisation times
- extremely short calculation times thanks to the use of the most recent technologies (multi-core, 64 bit)
- extremely short machining times/less toolwear thanks to innovative strategies (like for example adaptive clearing, and HSC machining)
- integration of numerous interfaces:
2D: DXF, DWG
3D: IGES, STEP, STL, Parasolid, ACIS, JT
Direct: Pro/E, Autodesk, SolidEdge, SolidWorks, Catia etc.

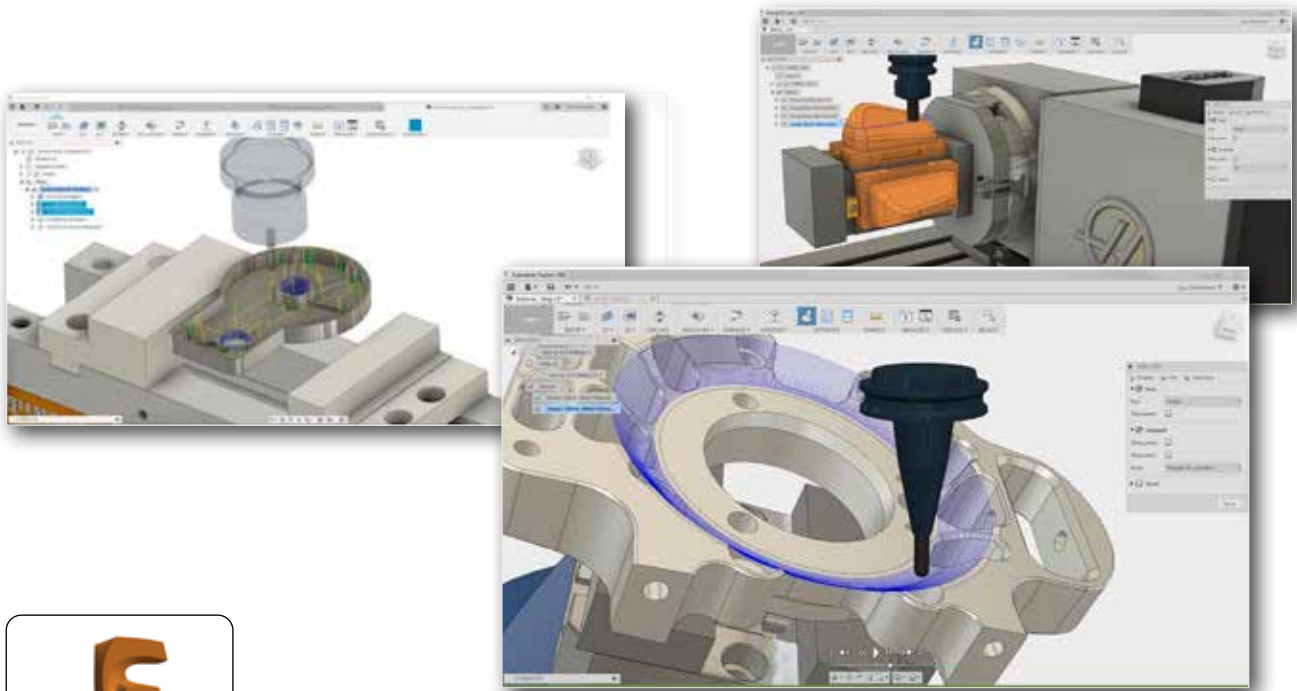

Adaptive Clearing - HSC roughing:

By means of Adaptive Clearing you can reduce the processing time by up to 40%!
Uniform cutting volume, constant feed, and uniform cross infeed

The HSC roughing strategy "Adaptive Clearing" is currently the trochoidal roughing method especially designed for machining machinable materials. Compared to conventional pocket roughing strategies, HSC roughing consistently remains in up-cut or down-cut operation **without performing full cuts**. Each cut - even in corner areas - is only made with the maximum specified transverse infeed.

Due to the special arrangement and the internal rounding of the traversing movements, a complete looping of the tool is avoided and the specified feed rate on the machine is kept on a constant level. Since the transverse infeed is constant as well, this results in a uniform cutting volume reducing the tool vibration by **significantly increasing the service life**.



Our CAD/CAM partner, the company HSMTEC GmbH, www.hsmtec.de

New definition of CAD/CAM

Fusion 360™ is the CAM solution combining CNC programming, simulation, and design with real-time collaboration as well as online project and data management in a single and easy-to-use product. Directly integrated with Autodesk® Fusion 360™ modeling, the users are able to rapidly complete routine tasks such as the model preparation and adaptation. You will be able to work with all major CAD formats so to be productive from the start.

Flexibility

Autodesk® Fusion 360™ breaks the boundaries of the traditional CAD/CAM applications by providing access to professional CNC programming tools whereby this is possible regardless of the existing CAD data format. Whether 2D/3D data, the software Autodesk® Inventor® or Solidworks® on Mac or PC Fusion 360™ covers it all.

Real-Time Collaboration

Fusion 360™ is also excellent for the collaboration. It helps to bring people and ideas together through a uniform interface controlled by the designer/programmer. Invite team members or partners and cooperate on important tasks as you are used to in social networks.

Quality

Fusion 360 uses the same proven HSM CAM Kernel HSMWorks and Inventor CAM does. In this manner, you are able to generate toolpaths very quickly, by reducing cycle times, machine and tool wear and by consequently producing components of the highest quality.

Our customers as well as the projects we carry out for our customers are as varied as our services. Here you can find a small selection of our references:



BOSCH

DAIMLER



RAMPF
discover the future



MARBACH



Branches of the company isel

With branches in China, Hungary, and the USA as well as numerous partners in Germany, Europe and worldwide, we are close by at any time.

isel USA, Inc.

69 Bloomingdale Road
USA, Hicksville, New York 11801
Phone: +1 516 / 595 7497
Fax: +1 516 / 595 7498
www.isel.com/en

isel (Suzhou) Automation Co.,Ltd

No.411 Jianlin Road SND,
CN-215151 Suzhou
Phone: +86 512 / 684 191 25
Fax: +86 512 / 666 735 56
www.isel.com/cn

isel Hungaria Kft.

József A. utca 38
H-8200 Veszprém
Phone: +36 88 / 406 682
Fax: +36 88 / 568 030
www.isel.com/hu

Distribution for:

Bulgaria, Serbia, Montenegro, Bosnia, Herzegovina, Croatia, Slovenia, Slovakia, Czech Republic, Poland, Baltic States (Estonia, Latvia, Lithuania), Ukraine, Belarus, Moldova, Kazakhstan, Georgia

Are you interested in „cnc systems“ and „spindle motors“?

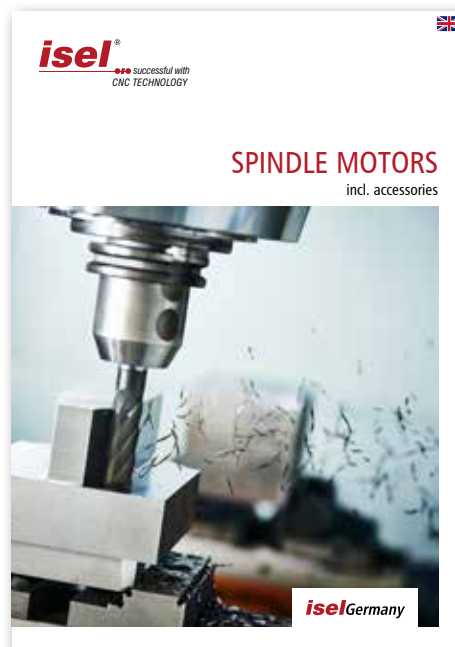
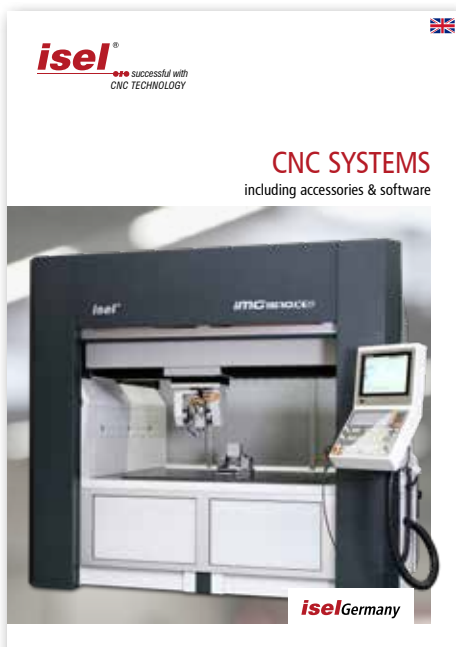

You can find our terms and conditions
on our website www.isel.com





isel[®]

••• *successful with
CNC TECHNOLOGY*

isel Germany GmbH
Bürgermeister-Ebert-Straße 40
D-36124 Eichenzell
Tel: +49 (0) 66 59/981 - 700
E-Mail: info@isel.com
www.isel.com

