



Designed for such tasks as simple and highly dynamic ones

Linear units are starting to become increasingly crucial as production as assembly processes continue to be automated. Linear units, which are equipped with a spindle drive, are mostly used only when high axial thrust and high level of accuracy are required. Each movement task demands an individual technically adequate solution to ensure the optimal level in terms of economic success.

Many linear units, which are equipped with spindle drives, are based on aluminum guide rails with rigid precision steel shafts that are combined with ball-guided shaft slides. You should trust a plug-in solution that can be integrated into the current technical system, or have a suitable linear system designed with all the necessary components for your application. The range of accessories offers you freedom when creating designs of individual design ideas.

Functional overview based on example LES 5

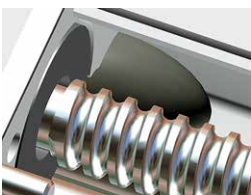
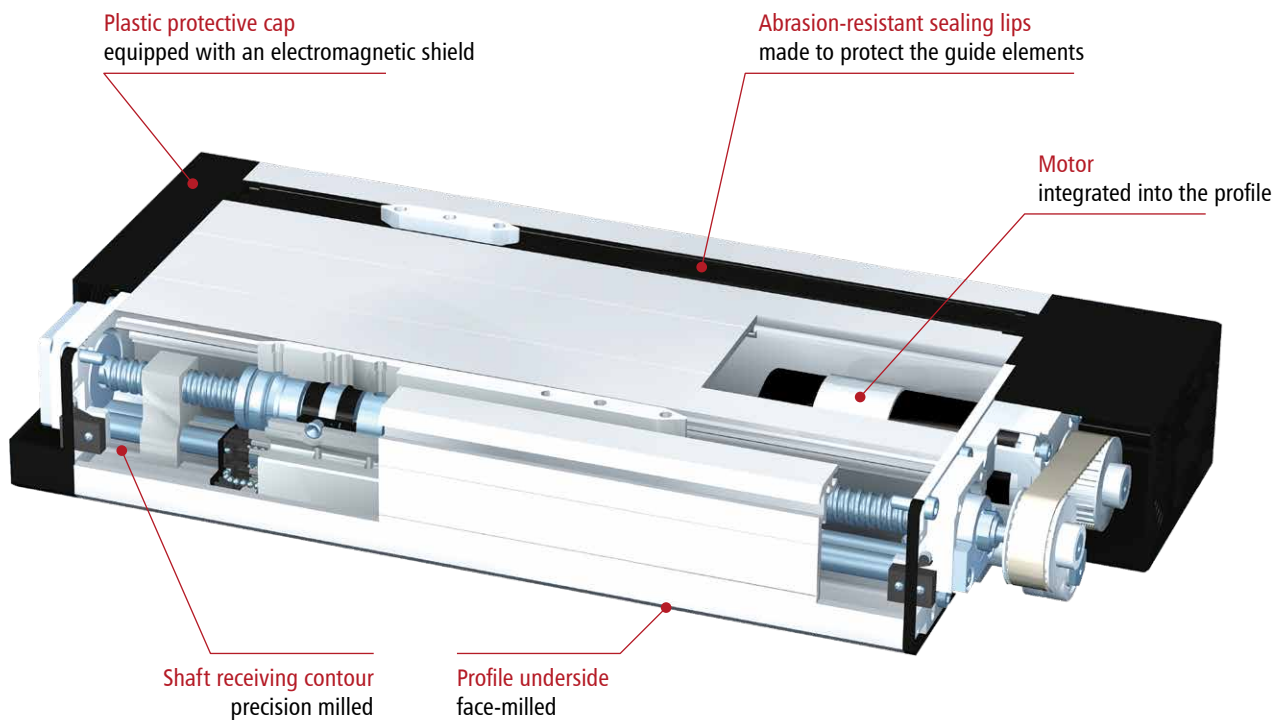

- End position buffering on 2 sides with soft PVC parabolic springs
- Counter bearing equipped with 2 needle sleeves

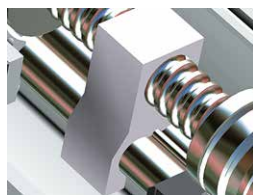

- Spindle support starting from a profile length of 1,500 mm done without restricting the travel range

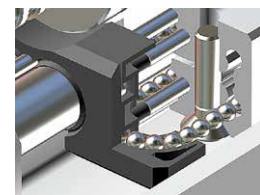

- Circulation of the ball inside the patented aluminum linear slide
- Glass-fiber reinforced deflection parts equipped with scrapers

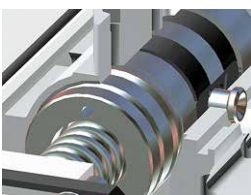

- Clearance-free ball screw nut equipped with scrapers
- Central lubricating device for ball screw nut and circulations

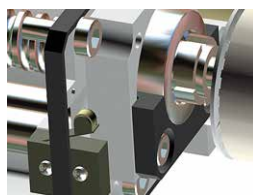

- Integrated overrun limit switch
- Spindle bearing equipped with angular ball bearings
- Axial position without clearance due to self-locking special slotted nut



- Belt deflection and connection electronics fully covered by the protective cap



Z-lift arrangement
three axes equipped with cross table
platforms and connecting brackets

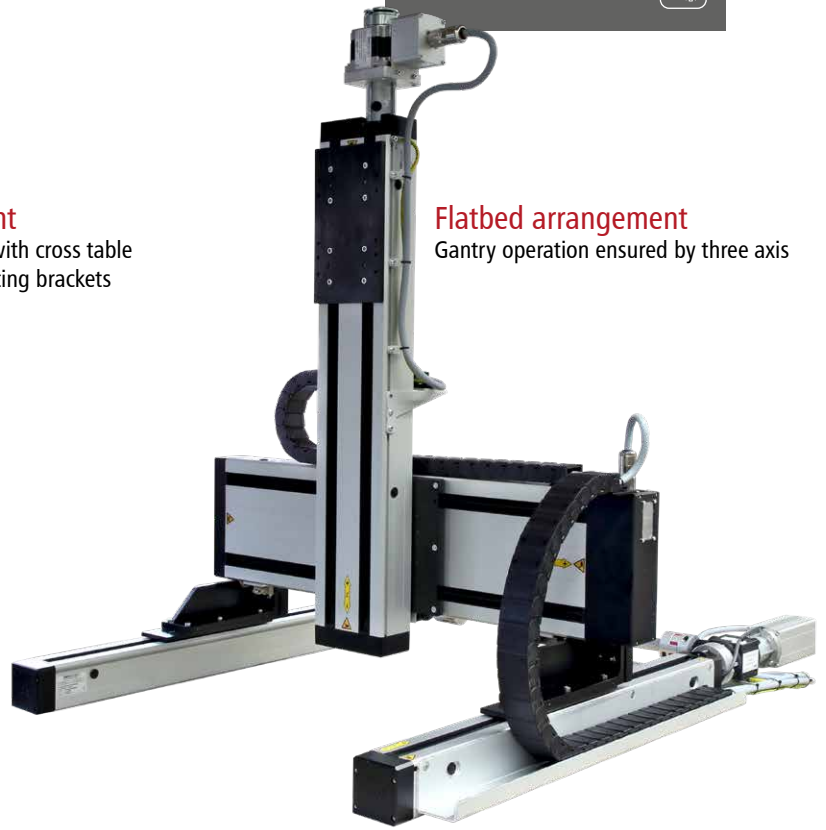

Flatbed arrangement
Gantry operation ensured by three axis

- 1 H-construction with two axis
- 2 Configuration of the boom with two axes
- 3 Configuration of the lifting boom with three axes
- 3 Configuration of the portal with four axis
- 3 Configuration of the flat bed with five axis

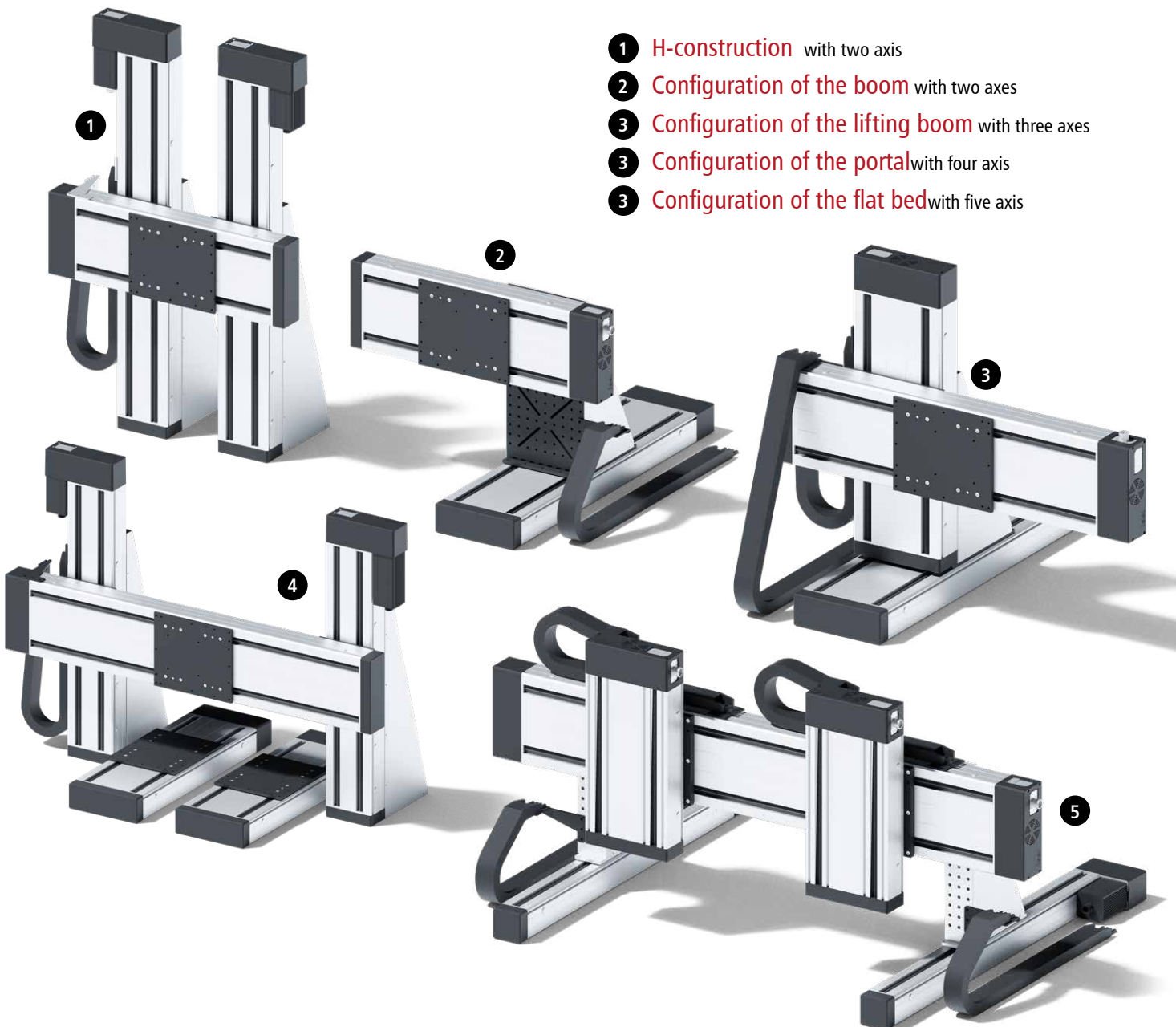



Linear unit is equipped with spindle drive ile 20/20

- Aluminum shaft mounting profile, anodized
- Milled clamping surface
- 20 precision steel rails equipped with steel slides
- Profile sealing is equipped with abrasion-resistant sealing lips
- 2 limit and reference switches
- Repeatability +/- 0.02 mm

Options

- Stepping or servo motor



The LES 5 undergoes the complete development! Two drives - one axis

With the linear unit, there is the possibility of incorporating two independent linear movements in simply one unit by installing two ball screw spindles. Therefore, 2 linear movements' realization is made possible with the smallest dimensions.

The linear units can be purchased with either one or two integrated ball screw drives (Ø 20 mm), pitches of either 5/10/20/40 mm, and with 2, 4 or 6 aluminum clamping plates.

Technical data

Moment of inertia Ix	705 cm ⁴
Moment of inertia Iy	2,807 cm ⁴
Centre of the area	39.5 mm
Cross-sectional area	54.22 cm ²
Material	EN AW-6060 T66
Anodizing	E6/EV1
Weight equipped with steel rail guide	20.6 kg/m
Weight equipped with both steel rail guide and ball screw spindle	22.8 kg/m

Order key

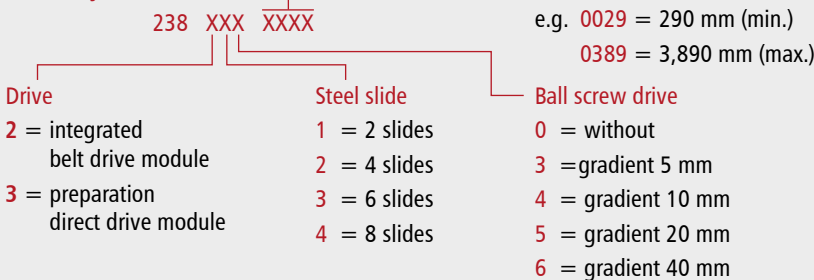

Version equipped with two spindles on demand.



Dimensional drawing

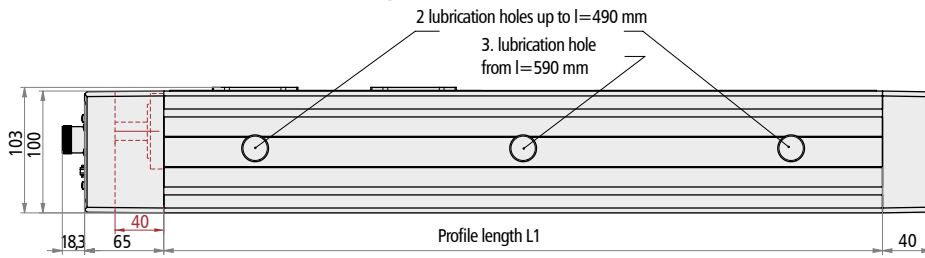

Length of stroke

with 2 x steel slides	L1-150 mm
with 4 x steel slides	L1-280 mm

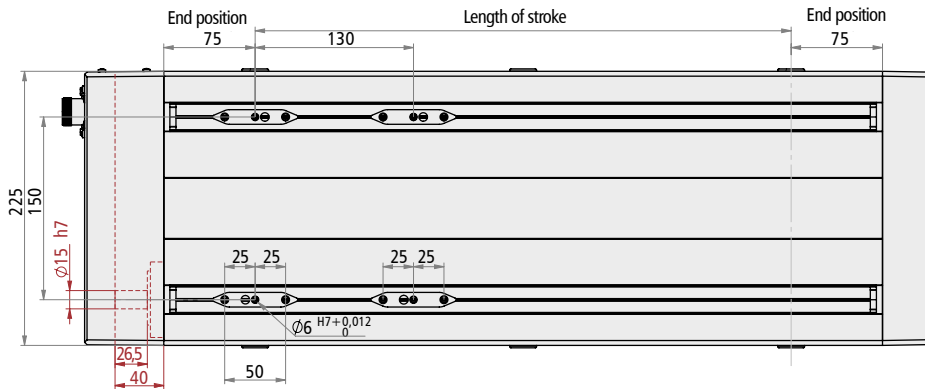

integrated belt drive module



direct drive module

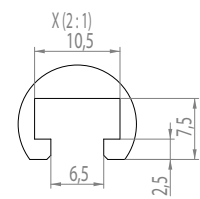
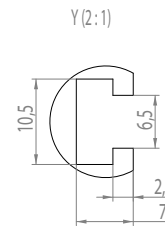
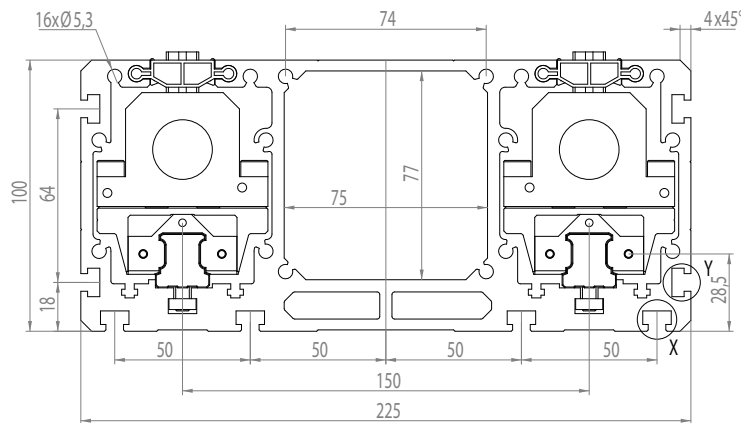
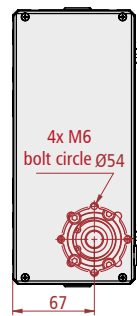

Permissible spindle speeds

ball screw spindle Ø20mm, equipped with fixed-loose bearing

Profile length [mm]	Spindle gradient p [mm]	max. permissible Spindle speed n permissible [1/min]	5	10	20
			maximum permissible Feed speed v permissible [mm/s]	maximum permissible Feed speed v permissible [mm/s]	maximum permissible Feed speed v permissible [mm/s]
490		6,000	500	1,000	2000
990		4,000	333	667	1,333
1,390		2,000	167	333	667
1,490*		4,000	333	667	1,333
1,990*		2000	167	333	667
2,490*		1500	125	250	500
2,990*		1,000	83	167	333
3,490*		700	58	117	233

*equipped with spindle support

Load figures

	Number of slides	
	2	4
C ₀	40,020 N	60,000 N
C	22,811 N	34,200 N
F1 _{stat}	40,020 N	60,000 N
F1 _{dyn}	22,811 N	34,200 N
F2 _{stat}	40,020 N	60,000 N
F2 _{dyn}	22,811 N	34,200 N
M0x	3,002 Nm	4,500 Nm
M0y	800 Nm	3,900 Nm
M0z	800 Nm	3,900 Nm
M _x	1,711 Nm	3,422 Nm
M _y	456 Nm	2,223 Nm
M _z	456 Nm	2,223 Nm

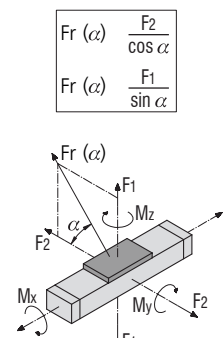



Linear unit equipped with spindle drive LES 4

- Aluminum shaft mounting profile W 75 x H 75 mm, and it is also naturally anodized
- Clamping surface and underside of milled profile
- Equipped with 2 precision steel shafts $\varnothing 12$ h6, material Cf53, and hardness of 60 ± 2 HRC
- Aluminum shaft slide WS 5/70 or 2 x WS 5/70 (L 70 mm), adjustable without clearance, centered Lubrication
- Ball screw drive equipped with 2.5 / 4 / 5 / 10 / 20 mm gradient
- Profile sealing equipped with abrasion-resistant sealing lips
- Die-cast aluminum endplates
- Equipped with 2 limit and/or reference switches, with a repeat accuracy of ± 0.02 mm
- Sealed angular contact ball placed inside of the drive steel flange



LES 4 equipped with a lateral belt drive module

Deflection

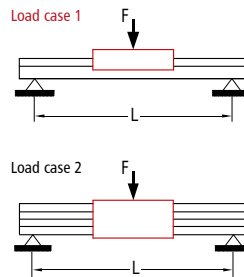
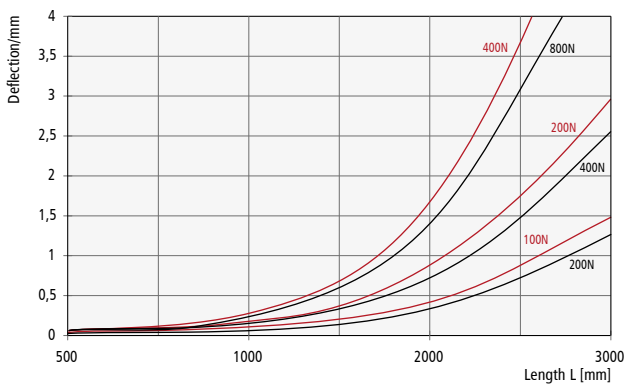

Options

- Black anodized aluminum profile
- Electromagnetic brake located inside the motor module or as extension of the drive spindle
- Steel slide
- Mounting kit equipped with an external limit switch (see accessories)

Upon request:

- Length measurement system
- Bellows cover
- Assembly on the left side of the motor module

Technical data

Aluminum profile LES 4	
Moment of inertia I_x	107.711 cm ⁴
Moment of inertia I_y	125.843 cm ⁴
Center of gravity (see dimensional drawing)	33.23 mm
Cross-sectional area	18.81 cm ²
Material	AlMgSiO, 5F22
Anodizing	E6/EV1
Weight with steel shafts	6.2 kg/m
Weight with both steel shafts and spindles	7.6 kg/m

No load torques [Ncm]

Torque (1/min)	Spindle gradient				
	2.5	4	5	10	20
500	15	15	16	17	18
1,500	19	19	19	20	21
3,000	23	24	24	25	26

Order key

234 XXX 0XXX

Drive
 0 = Preparation of direct drive module
 1 = Preparation of belt drive module

Linear guide slide
 0 = 1 slide 70 mm
 1 = 1 slide 200 mm
 2 = 2 slides 70 mm

Ball screw drive
 0 = without
 1 = gradient 2.5 mm
 2 = gradient 4 mm
 3 = gradient 5 mm
 4 = gradient 10 mm
 5 = gradient 20 mm
 6 = gradient 20 mm (equipped with return of the ball)

Profile lengths (L1)*
 e.g. 029 = 290 mm (min.)
 299 = 2,990 mm (max.)

*The data is shortened by the last digit.
 Ordering standard profile lengths can be done in 100 mm increments.



LES 4 installed with direct drive



Dimensional drawing

Length of stroke

with 1 x WS 5/70 = L1 -150 mm
with 2 x WS 5/70 = L1 -280 mm

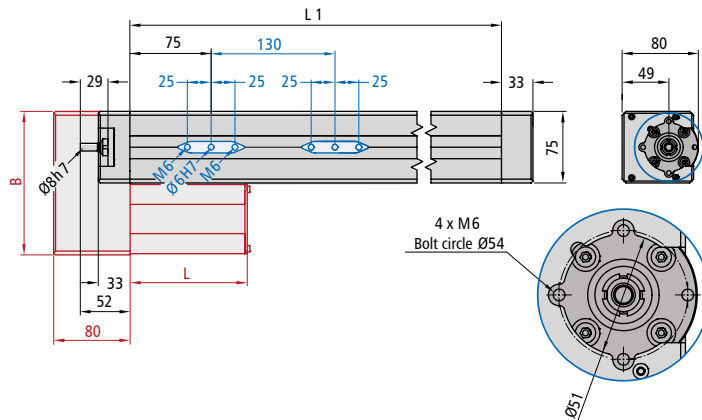

Aluminium profile

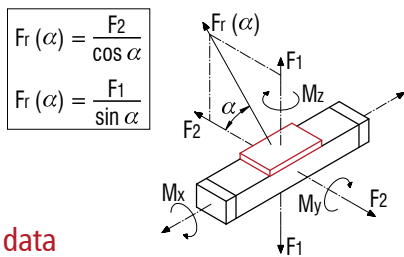
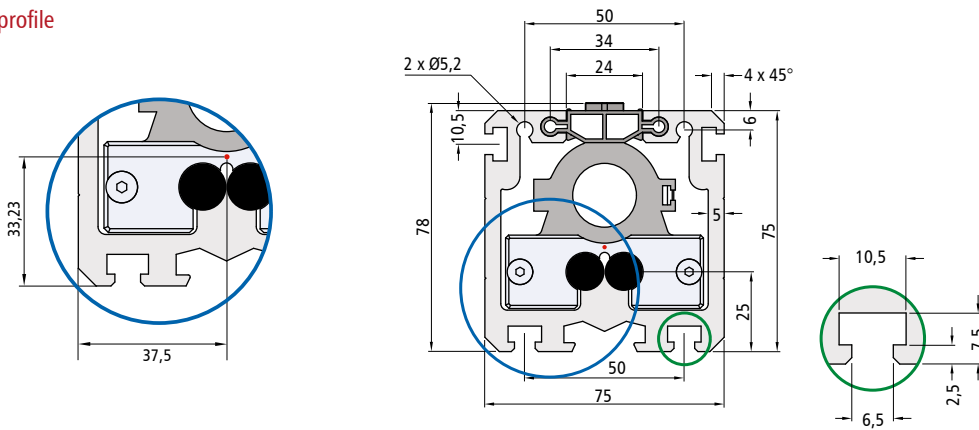

$$F_r(\alpha) = \frac{F_2}{\cos \alpha}$$

$$F_r(\alpha) = \frac{F_1}{\sin \alpha}$$

Load data

LES 4 with a WS 5/70		LES 4 with two WS 5/70	
C ₀	2577 N	C ₀	5153 N
C	1461 N	C	2319 N
F ₁ static	2201 N	F ₁ static	4401 N
F ₁ dynamic	1248 N	F ₁ dynamic	1981 N
F ₂ static	2577 N	F ₂ static	5153 N
F ₂ dynamic	1461 N	F ₂ dynamic	2319 N
M _x static	31 Nm	M _x static	46 Nm
M _y static	82 Nm	M _y static	182 Nm
M _z static	96 Nm	M _z static	213 Nm
M _x dynamic	14 Nm	M _x dynamic	21 Nm
M _y dynamic	47 Nm	M _y dynamic	82 Nm
M _z dynamic	55 Nm	M _z dynamic	96 Nm

permissible spindle speeds

LES 4 Profile length L [mm]	Spindle gradient p [mm] maximum per- missible Spindle speed n perm. [1/min]	2.5	4	5	10	20
		maximum permissible Feed speed v perm. [mm/s]				
490	4,000	167	267	333	667	1333
990	3,000	125	200	250	500	1000
1,390	1,500	63	100	125	250	500
1,490*	3,000	125	200	250	500	1000
1,990*	1,650	69	110	138	275	550
2,490*	1,050	44	70	88	175	350
2,990*	750	31	50	63	125	250

*equipped with spindle support



Linear unit equipped with spindle drive LES 5

- Aluminum shaft mounting profile W 225 x H 75 mm, and it is also naturally anodized
- Milled clamping surface and underside of profile
- Equipped with 4 precision steel shafts $\varnothing 12\text{ h6}$, material Cf53, and hardness $60 \pm 2\text{ HRC}$
- Aluminum shaft slide WS 5/70 or 2 x WS 5/70 (L 70 mm), adjustable without clearance, centered Lubrication
- Ball screw drive equipped with 2.5 / 4 / 5 / 10 / 20 mm gradient
- Profile sealing by abrasion-resistant sealing lips
- Die-cast aluminum endplates
- Equipped with 2 limit and/or reference switches, with a repeat accuracy of $\pm 0.02\text{ mm}$
- Sealed angular contact ball placed inside of the drive steel flange



LES 5 equipped with an integrated belt drive module

Deflection

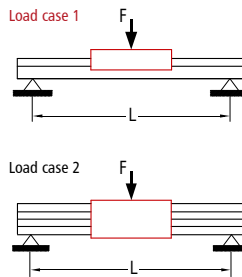
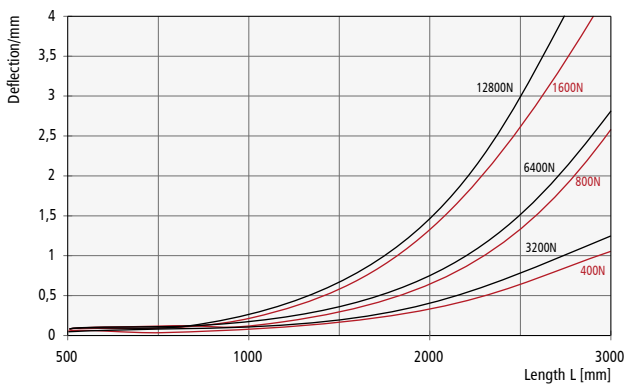

Options

- Black anodized aluminum profile
- Electromagnetic brake located inside the motor module or as extension of the drive spindle
- Steel slide
- End limit switch equipped with mounting-kit (see accessories)

Upon request

- Length measurement system
- Bellows cover

Technical data

Aluminum profile LES 5	
Moment of inertia I_x	2361,654 cm ⁴
Moment of inertia I_y	298,925 cm ⁴
Center of gravity (see dimensional drawing)	33.39 mm
Cross-sectional area	42.49 cm ²
Material	AlMgSiO, 5F22
Anodizing	E6/EV1
Weight with steel shafts	13.8 kg/m
Weight with both steel shafts and spindles	15.2 kg/m

No load torques [Ncm]

Torque (1/min)	Spindle gradient				
	2.5	4	5	10	20
500	15	15	16	17	18
1,500	19	19	19	20	21
3,000	23	24	24	25	26

Order key

234 XXX 0XXX

Drive
3 = Preparation of direct drive module
4 = Preparation of belt drive module

Linear guide slide
0 = 2 slides 70 mm
1 = 2 slides 200 mm
2 = 4 slides 70 mm

Ball screw drive
0 = without
1 = gradient 2.5 mm
2 = gradient 4 mm
3 = gradient 5 mm
4 = gradient 10 mm
5 = gradient 20 mm
6 = gradient 20 mm (equipped with return of the ball)

Profile lengths (L1)*
 e.g. **029** = 290 mm (min.)
299 = 2,990 mm (max.)

*The data is shortened by the last digit.
 Ordering standard profile lengths can be done in 100 mm increments.



LES 5 equipped with direct drive



Dimensional drawing

Length of stroke
 with 2 x WS 5/70 = L1 -150 mm
 with 4 x WS 5/70 = L1 -280 mm

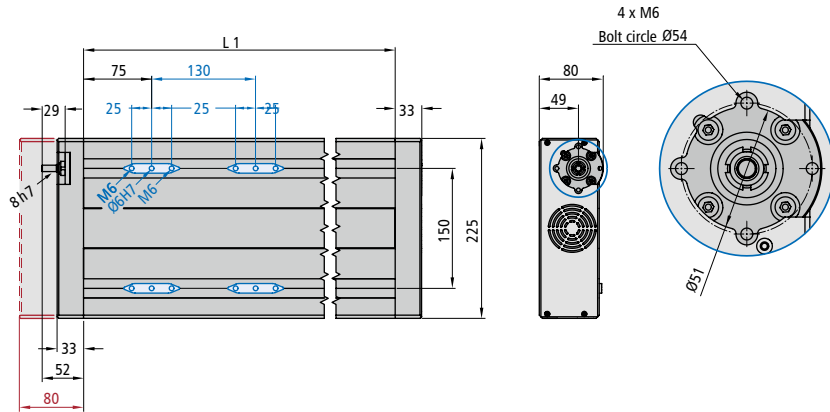

Aluminium profile

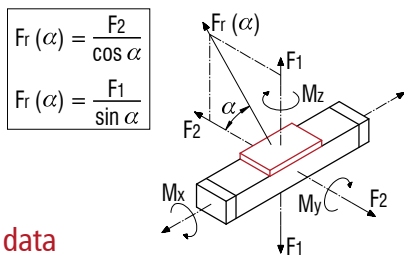
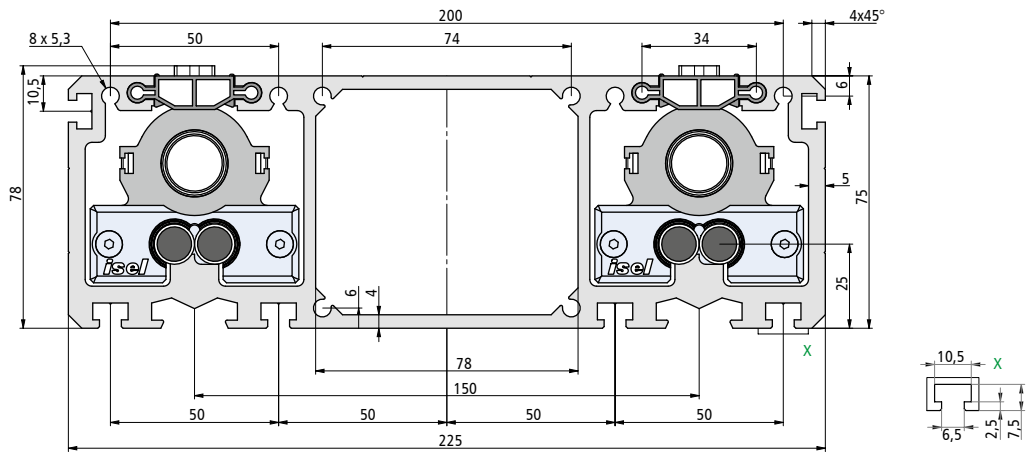

Load data

LES 5 with two WS 5/70		LES 5 with four WS 5/70	
C ₀	5153 N	C ₀	6606 N
C	2319 N	C	3746 N
F ₁ static	4401 N	F ₁ static	5642 N
F ₁ dynamic	1981 N	F ₁ dynamic	3198 N
F ₂ static	5153 N	F ₂ static	6606 N
F ₂ dynamic	2319 N	F ₂ dynamic	3746 N
M _x static	377 Nm	M _x static	423 Nm
M _y static	164 Nm	M _y static	367 Nm
M _z static	192 Nm	M _z static	429 Nm
M _x dynamic	169 Nm	M _x dynamic	240 Nm
M _y dynamic	74 Nm	M _y dynamic	208 Nm
M _z dynamic	87 Nm	M _z dynamic	243 Nm

permissible spindle speeds

LES 5 Profile length L [mm]	Spindle gradient p [mm] maximum permissible Spindle speed n perm. [1/min]	2.5	4	5	10	20
		maximum permissible Feed speed v perm. [mm/s]				
490	4,000	167	267	333	667	1333
990	3,000	125	200	250	500	1000
1,390	1,500	63	100	125	250	500
1,490*	3,000	125	200	250	500	1000
1,990*	1,650	69	110	138	275	550
2,490*	1,050	44	70	88	175	350
2,990*	750	31	50	63	125	250

*equipped with spindle support



Linear unit is equipped with spindle drive LES 6

- Aluminum shaft mounting profile W 150 x H 75 mm, naturally anodized
- Clamping surface and underside of milled profile
- Equipped with 4 precision steel shafts $\varnothing 12$ h6, material Cf53, and hardness 60 ± 2 HRC
- Aluminum shaft slide WS 5/70 or 2 x WS 5/70 (L 70 mm), adjustable without clearance, centered Lubrication
- Ball screw drive equipped with 2.5 / 4 / 5 / 10 / 20 mm gradient
- Profile sealing equipped with abrasion-resistant sealing lips
- Die-cast aluminum endplates
- Equipped with 2 limit and/or reference switches, with a repeat accuracy of ± 0.02 mm
- Sealed angular contact ball placed inside of the drive steel flange



LES 6 is equipped with side belt drive module

Deflection

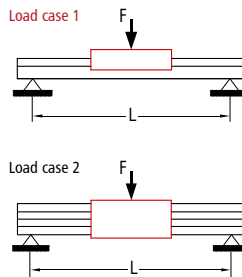
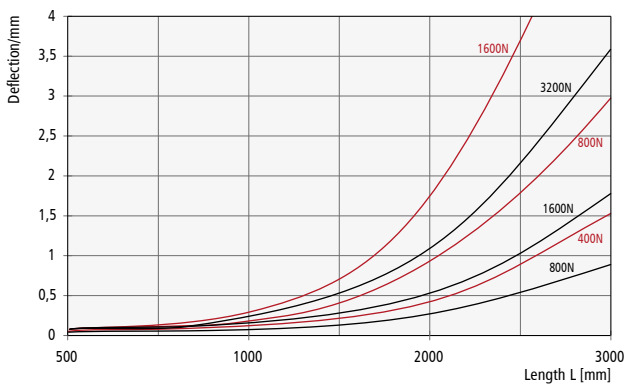

Options

- Black anodized aluminum profile
- Electromagnetic brake located inside the motor module or as extension of the drive spindle
- Steel slide
- End limit switch equipped with mounting-kit (see accessories)

Upon request

- Length measurement system
- Bellows cover
- Assembly on the left side of the motor module

Technical data

Aluminum profile LES 6	
Moment of inertia I_x	707,100 cm ⁴
Moment of inertia I_y	212,200 cm ⁴
Center of gravity (see dimensional drawing)	32,78 mm
Area	30,07 cm ²
Material	AlMgSiO, 5F22
Anodizing	E6/EV1
Weight with steel shafts	11.4 kg/m
Weight with both steel shafts and spindles	12.8 kg/m

No load torques [Ncm]

Torque (1/min)	Spindle gradient				
	2.5	4	5	10	20
500	17	17	18	20	21
1,500	20	20	22	24	25
3,000	24	25	26	26	30

Order key

234 XXX 0XXX

Drive
6 = Preparation of direct drive module
7 = Preparation of belt drive module

Linear guide slide
0 = 2 slides 70 mm
1 = 2 slides 200 mm
2 = 4 slides 70 mm

Ball screw drive
0 = without
1 = gradient 2.5 mm
2 = gradient 4 mm
3 = gradient 5 mm
4 = gradient 10 mm
5 = gradient 20 mm
6 = gradient 20 mm (equipped with return of the ball)

Profile lengths (L1)*
 E:G: **029** = 290 mm (min.)
299 = 2,990 mm (max.)

*The data is shortened by the last digit.
 Ordering standard profile lengths can be done in 100 mm increments.



LES 6 equipped with direct drive



Dimensional drawing

Length of stroke
 with 2 x WS 5/70 = L1 -150 mm
 with 4 x WS 5/70 = L1 -280 mm

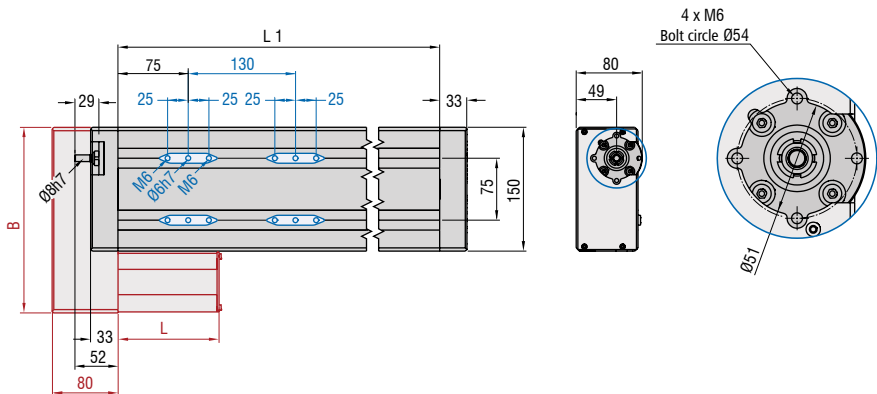

Aluminium profile

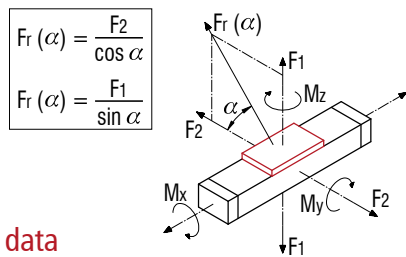
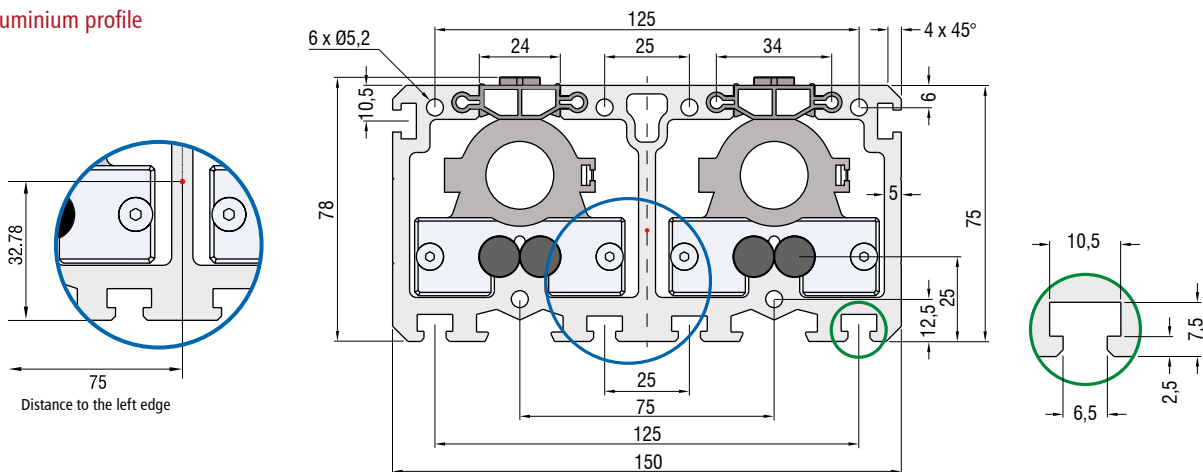

$$F_r(\alpha) = \frac{F_2}{\cos \alpha}$$

$$F_r(\alpha) = \frac{F_1}{\sin \alpha}$$

Load data

LES 6 with two WS 5/70		LES 6 with four WS 5/70	
C ₀	5153 N	C ₀	6606 N
C	2319 N	C	3746 N
F ₁ static	4401 N	F ₁ static	5642 N
F ₁ dynamic	1981 N	F ₁ dynamic	3198 N
F ₂ static	5153 N	F ₂ static	6606 N
F ₂ dynamic	2319 N	F ₂ dynamic	3746 N
M _x static	212 Nm	M _x static	212 Nm
M _y static	164 Nm	M _y static	367 Nm
M _z static	192 Nm	M _z static	429 Nm
M _x dynamic	95 Nm	M _x dynamic	120 Nm
M _y dynamic	74 Nm	M _y dynamic	208 Nm
M _z dynamic	87 Nm	M _z dynamic	243 Nm

permissible spindle speeds

LES 6 Profile length L [mm]	Spindle gradient p [mm] maximum per- missible Spindle speed n perm. [1/min]	2.5	4	5	10	20
		maximum permissible Feed speed v perm. [mm/s]				
490	4,000	167	267	333	667	1333
990	3,000	125	200	250	500	1000
1,390	1,500	63	100	125	250	500
1,490*	3,000	125	200	250	500	1000
1,990*	1,650	69	110	138	275	550
2,490*	1,050	44	70	88	175	350
2,990*	750	31	50	63	125	250

*equipped with spindle support



Mounting kit is equipped with bevel gear



- 1 Angle drives
- 2 split clutch housing is equipped with shaft coupling WK 40/60
- 3 LES 4, LES 6 or LES 5 (preparation of direct drive)
- 4 Coupling for transmission shaft Ø25
- 5 Transmission shaft Ø25
- 6 The procedure of pillow block bearing is recommended from a transmission wavelength of 1500 mm

Installation options

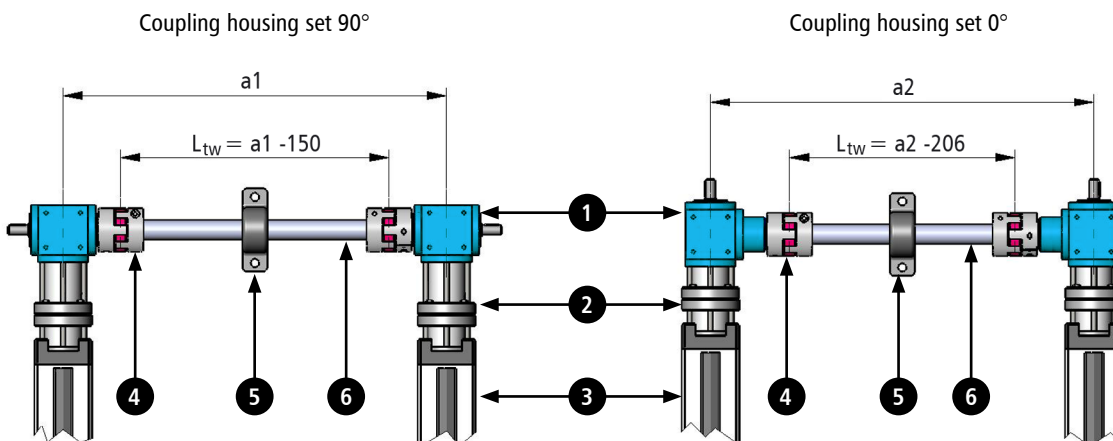

Order data

Mounting kit is equipped with bevel gear

It is equipped with H-construction LES 4 / LES 6 / LES 5, Mounting 0°

Scope of delivery: 2x 1, 2x 2, 2x 4
Item-Number: 216150 0001

In case of an H-construction for LES 4 / LES 6 / LES 5, Fastening 90°

Scope of delivery: 2x 1, 2x 2, 2x 4
Part No.: 216150 0002

Transmission shaft

Hollow shaft of Ø 25 mm x 4 mm, blank 1000 mm
Part No.: 219001 0125

Hollow shaft of Ø 25 mm x 4 mm, blank 2000 mm
Part No.: 219001 0225

Coupling/Pillow Bearing

Coupling for transmission shaft
Conversion is done from 12 to 25 mm, 2 pcs.
Part No.: 218050 0002

Pillow bearing for the transmission shaft
PU 1 piece
Part No.: 896202 5562



Dimensional drawing

Pillar bearing

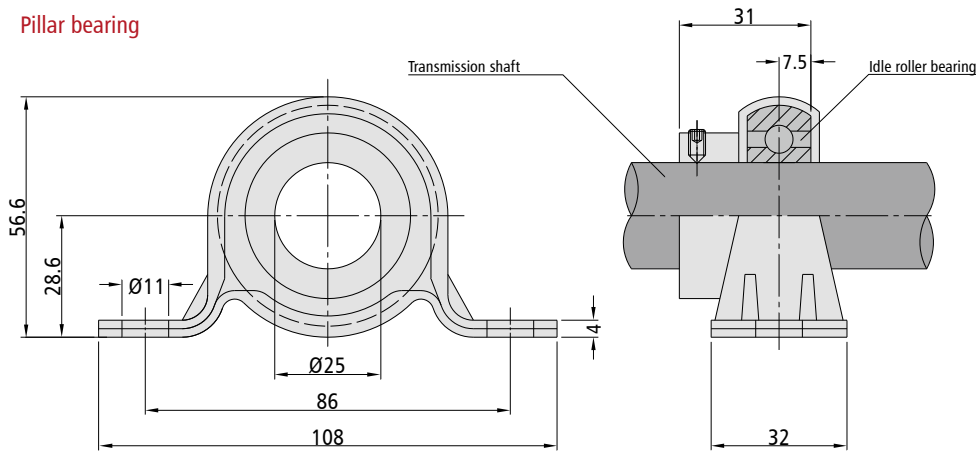

Technical data

Pillow block bearing is placed to avoid vibrations and to support the transmission shaft (recommended from a shaft length of 1500 mm)

Transferrable Torque	18 Nm
Body Weight of Coupling	0.3 kg
Weight of the shaft	0.540 kg/m
Moment of inertia of both couplings	$2.68 \cdot 10^{-4} \text{ kg m}^2$
Moment of inertia of the shaft	$8.171 \cdot 10^{-6} \text{ kg m}^2/100 \text{ mm}$

Angle drives

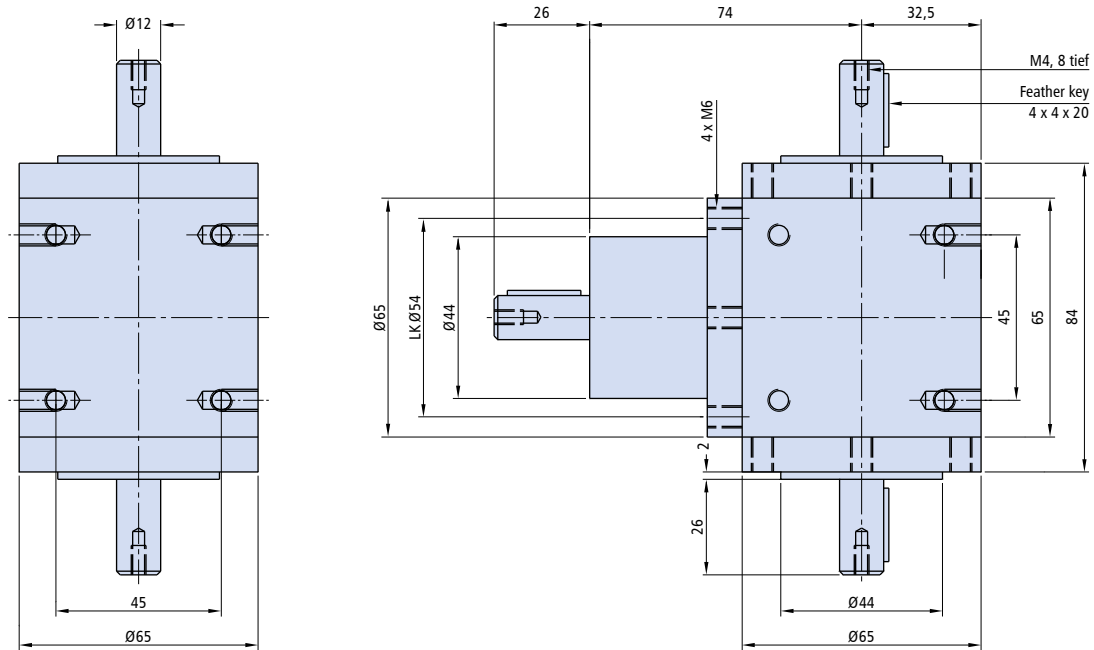

Coupling

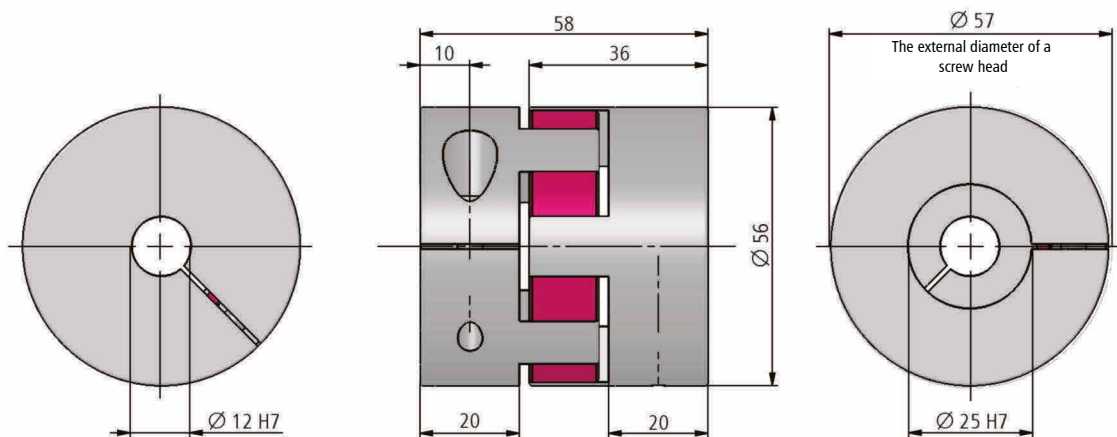



Engine modules

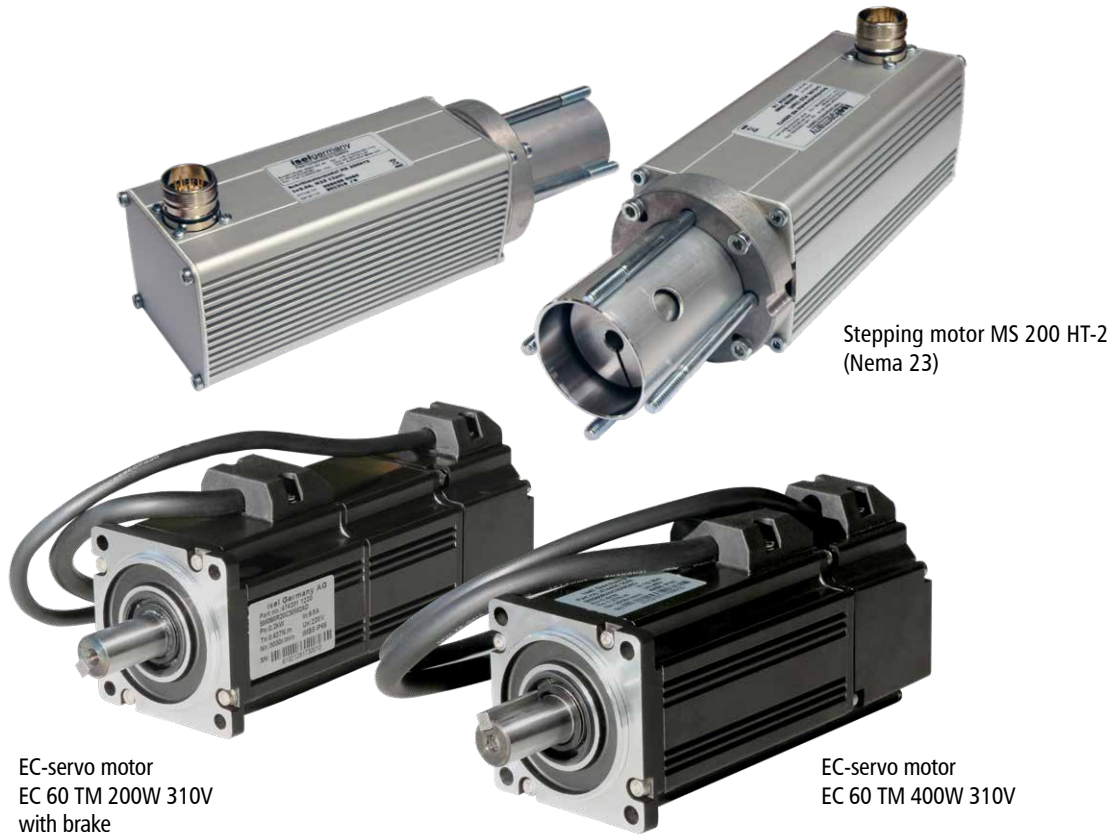

ile 20/20

Direct drive	Part No.	Part No. equipped with brake	1-axis controller	Multi-axis controller	Motor cable Controller	Motor cable Control cabinet	Encoder line
EC-servo motor EC 60 TM (200W, 48V, 8-pole)	396421 006015	396421 026015	MC 1-20	iCU-EC / iPU-EC	392759 XX00	392760 XX00	392740 XX00
EC-servo motor EC 60 TM (200W, 310V, 8-pole)	396421 007015	396421 027015	MC 1-40	iCU-EC / iPU-EC	392759 XX00	392305 XX00	392740 XX00
EC-servo motor EC 60 TM (400W, 48V, 8-pole)	396440 008015	396440 028015	MC 1-20	iCU-EC / iPU-EC		392303 XX00	392740 XX00
EC-servo motor EC 60 TM (400W, 310V, 8-pole)	396440 007015	396440 027015	MC 1-40	iCU-EC / iPU-EC	392759 XX00	392305 XX00	392740 XX00
EC-servo motor EC 80 TM (750W, 310V, 8-pole)	396475 007015	396475 027015	MC 1-40	iCU-EC / iPU-EC	392759 XX00	392305 XX00	392740 XX00

Integrated drive	Part No.	Part No. equipped with brake	1-axis controller	Multi-axis controller	Motor cable Controller	Motor cable Control cabinet	Encoder line
EC-servo motor EC 60 TM (200W, 48V, 8-pole)	396421 1060	396421 1260	MC 1-20	iCU-EC / iPU-EC	392759 XX00	392760 XX00	392740 XX00
EC-servo motor EC 60 TM (200W, 310V, 8-pole)	396421 1070	396421 1270	MC 1-40	iCU-EC / iPU-EC	392307 XX00	392305 XX00	392740 XX00
EC-servo motor EC 60 TM (400W, 48V, 8-pole)	396440 1080	396440 1280	MC 1-20	iCU-EC / iPU-EC		392303 XX00	392740 XX00
EC-servo motor EC 60 TM (400W, 310V, 8-pole)	396440 1070	396440 1270	MC 1-40	iCU-EC / iPU-EC	392307 XX00	392305 XX00	392740 XX00



LES 4 / 5 / 6

Direct drive	Part No.	Part No. equipped with brake	1-axis controller	Multi-axis controller	Motor cable Controller	Motor cable Control cabinet	Encoder line
Stepping motor MS 135 (Nema 23)	396055 0060		IT 116 Flash	iMC-P / iMC-S8	392750 XX00		
Stepping motor MS 200 HT-2 (Nema 23)	396058 0060	396058 0260	IT 116 Flash	iMC-P / iMC-S8	392750 XX00		
EC-servo motor EC 60 TM (200W, 48V)	396421 0060	396421 0260	MC 1-20	iCU-EC / iPU-EC	392759 XX00	392760 XX00	392740 XX00
EC-servo motor EC 60 TM (200W, 310V)	396421 0070	396421 0270	MC 1-40	iCU-EC / iPU-EC	392759 XX00	392305 XX00	392740 XX00
EC-servo motor EC 60 TM (400W, 48V)	396440 0080	396440 0280	MC 1-20	iCU-EC / iPU-EC		392303 XX00	392740 XX00
EC-servo motor EC 60 TM (400W, 310V)	396440 0070	396440 0270	MC 1-40	iCU-EC / iPU-EC	392759 XX00	392305 XX00	392740 XX00
EC servo motor EC 80 TM (750W, 310V)	396475 0070	396475 0270	MC 1-40	iCU-EC / iPU-EC	392759 XX00	392305 XX00	392740 XX00
Stepping motor MS 300 HT-2 (Nema 34)	396082 0060	396082 0260	iMC-S8	iMC-S8	392750 XX00		
Stepping motor MS 600 HT (Nema 34)	396085 0060		iMC-S8	iMC-S8	392750 XX00		
Stepping motor MS 900 HT (Nema 34)	396088 0060		iMC-S8	iMC-S8	392750 XX00		

LES 5

Integrated drive	Part No.	Part No. equipped with brake	1-axis controller	Multi-axis controller	Motor cable Controller	Motor cable Control cabinet	Encoder line
Stepping motor MS 200 HT-2 (Nema 23)	396058 1060	396058 1260	IT 116 Flash	iMC-P / iMC-S8	392740 XX00		
EC-servo motor EC 60 TM (200W, 48V)	396421 1060	396421 1260	MC 1-20	iCU-EC / iPU-EC	392759 XX00	392760 XX00	392740 XX00
EC-servo motor EC 60 TM (200W, 310V)	396421 1070	396421 1270	MC 1-40	iCU-EC / iPU-EC	392307 XX00	392305 XX00	392740 XX00
EC-servo motor EC 60 TM (400W, 48V)	396440 1080	396440 1280	MC 1-20	iCU-EC / iPU-EC		392303 XX00	392740 XX00
EC-servo motor EC 60 TM (400W, 310V)	396440 1070	396440 1270	MC 1-40	iCU-EC / iPU-EC	392307 XX00	392305 XX00	392740 XX00

LES 4 / 6

Drive with lateral assembly	Part No.	Part No. equipped with brake	1-axis controller	Multi-axis controller	Motor cable Controller	Motor cable Control cabinet	Encoder line
Stepping motor MS 200 HT-2 (Nema 23)	396058 2060	396058 2260	IT 116 Flash	iMC-P			
EC-servo motor EC 60 TM (200W, 48V)	396421 2060	396421 2260	MC 1-20	iCU-EC / iPU-EC	392759 XX00	392760 XX00	392740 XX00
EC-servo motor EC 60 TM (200W, 310V)	396421 2070	396421 2270	MC 1-40	iCU-EC / iPU-EC	392307 XX00	392305 XX00	392740 XX00
EC-servo motor EC 60 TM (400W, 48V)	396440 2080	396440 2280	MC 1-20	iCU-EC / iPU-EC		392303 XX00	392740 XX00
EC-servo motor EC 60 TM (400W, 310V)	396440 2070	396440 2270	MC 1-40	iCU-EC / iPU-EC	392307 XX00	392305 XX00	392740 XX00

XX = cable length in meters



Accessories LES

Energy guiding chain 3

- PU 1 piece at 1 m
- Part No.: 219204 1000

Connection elements designed for e-chain 3

- equipped with strain relief
- PU 1 set
- Part No.: 219205 0002



Dimensional drawing

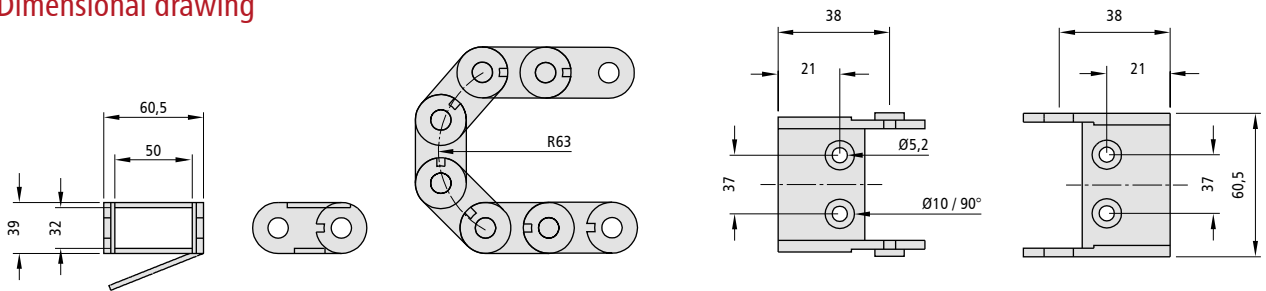

Gas spring attachment-kit

- Stroke 220 mm
- 490 nominal length
- Part No.: 216450 0001



Gas spring attachment-kit

- Stroke 300 mm
- 690 nominal length
- Part No.: 216451 0001

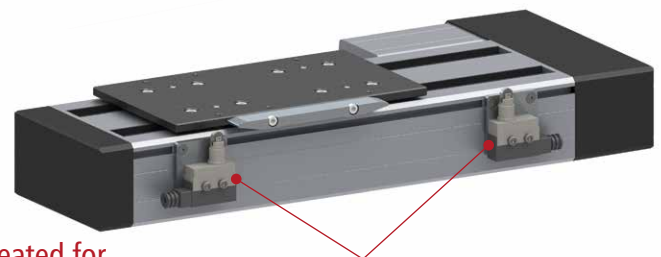

Limit switch mounting kit LES 4

- made for external limit switches
- Part No.: 216460 0001

Assembly set is created for sealing air

- made for LES4 - LES6
- Part No.: 216460 0006

Limit switch mounting kit LES 5

- made for external limit switches
- Part No.: 216460 0002

Mounting plate designed for screwing from above

- made for LES4 Part No.: 623025 6837
- made for LES5 Part No.: 623025 6833
- made for LES6 Part No.: 675015 0362

Limit switch mounting-kit LES 6

- made for external limit switches
- Part No.: 216460 0003



Connection angle WV

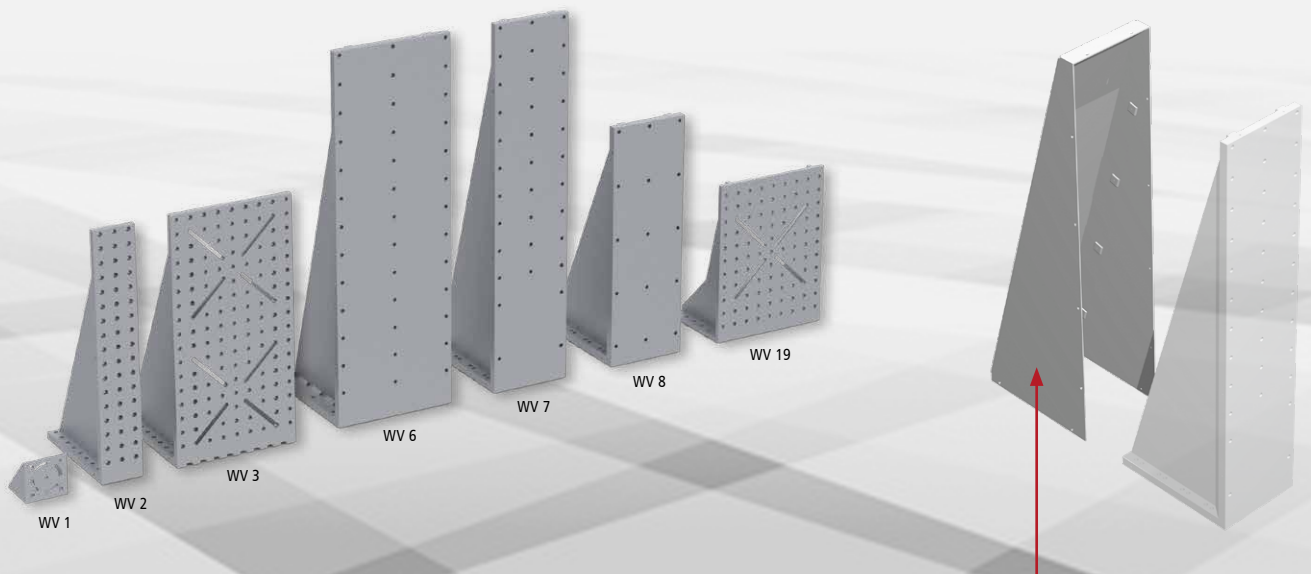

WV 1

- blank
- Aluminum cast (0.2 kg)
- L71 x W75 x H71

Part No.: [209110 0010](#)

WV 2

- blank
- Aluminum cast (2.6 kg)
- L221 x W75 x H446

Part No.: [209110 0022](#)

WV 3

- blank
- Cast aluminum (5.8 kg)
- L221 x W221 x H446

Part No.: [209110 0032](#)

WV 6

- blank
- Aluminum, welded (13.3 kg)
- L220 x W220 x H670

Part No.: [209110 0060](#)

WV 7

- blank
- Aluminum, welded (10.8 kg)
- L220 x W145 x H670

Part No.: [209110 0070](#)

WV 8

- blank
- Aluminum, welded (7.4 kg)
- L222 x W145 x H446

Part No.: [209110 0080](#)

WV 19

- blank
- Aluminum, cast aluminum (2.5 kg)
- L150 x W221 x H300

Part No.: [209110 0190](#)

Cover plate designed for WV 2

- naturally anodized
- Aluminum sheet (0.8 kg)

Part No.: [209110 0021](#)

Cover plate designed for WV 3

- naturally anodized
- Aluminum sheet (1.15 kg)

Part No.: [209110 0031](#)

Cover plate designed for WV 6

- naturally anodized
- Aluminum sheet (1.8 kg)

Part No.: [209110 0061](#)

Cover plate designed for WV 7

- naturally anodized
- Aluminum sheet (1.5 kg)

Part No.: [209110 0071](#)

Cover plate designed for WV 8

- naturally anodized
- Aluminum sheet (1 kg)

Part No.: [209110 0081](#)

Cover plate designed for WV 19

- naturally anodized
- Aluminum sheet (0.8 kg)

Part No.: [209110 0191](#)



Connection angle WV

WV 1: L 71 x W 75 x H 71 mm

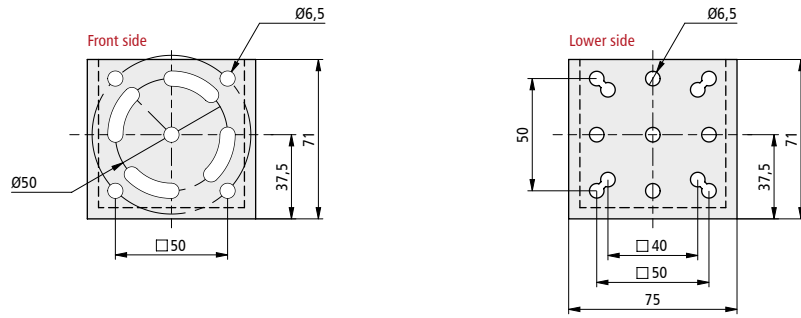

WV 2: L 221 x W 75 x H 446 mm

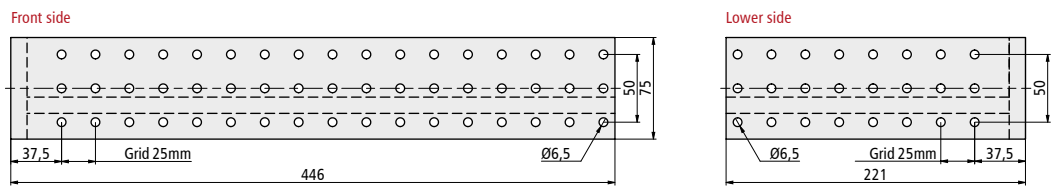

WV 3: L 221 x W 221 x H 446 mm

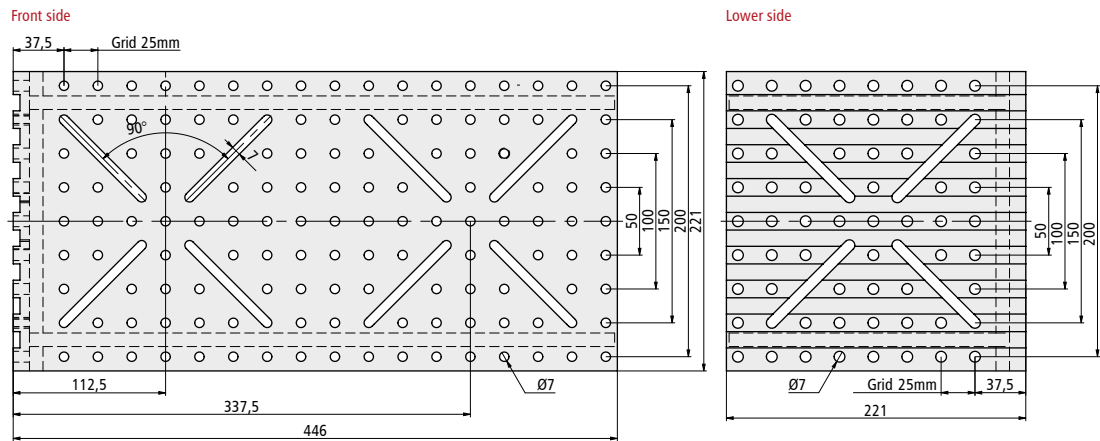

WV 6: L 220 x W 220 x H 670 mm

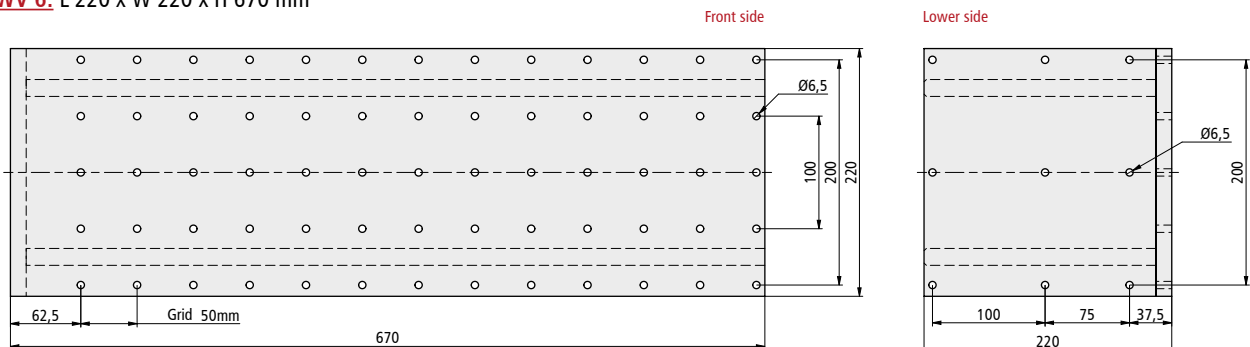



Connection angle WV

WV 7: L 220 x W 145 x H 670 mm

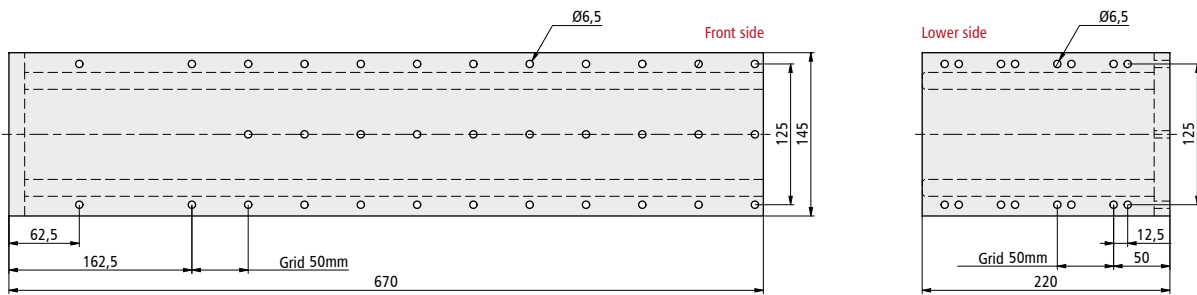

WV 8: L 222 x W 145 x H 446 mm

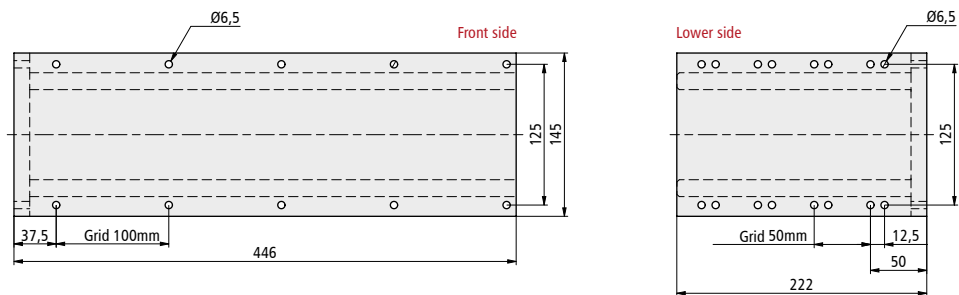

WV 19: L 150 x W 221 x H 300 mm

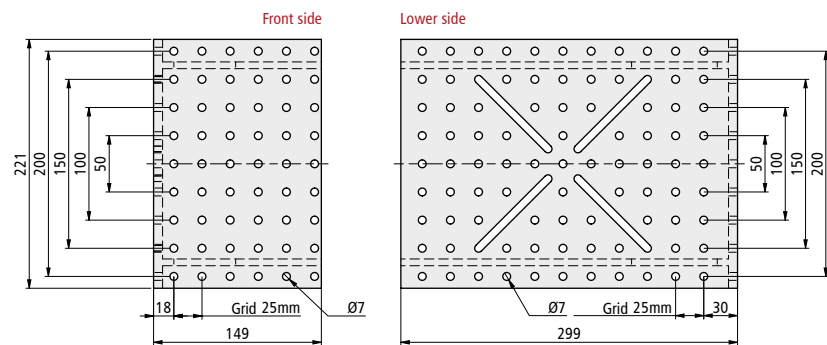



Slide plates PS

PS 1: L 125 x W 70 x H 7.7 mm

Assembly on:

: LES 4 with 1 x WS 5/70

Part No.: **277001**

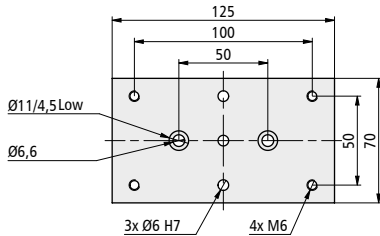

PS 2: L 255 x W 70 x H 7.7 mm

Assembly on:

LES 4 with 2 x WS 5/70

Fastening option for: connecting bracket WV 2 / WV 5

Part No.: **277002**

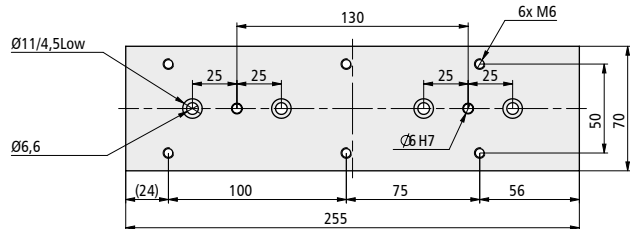

PS 3: L 220 x W 125 x H 7.5 mm

Assembly on:

LES 5 with 2 x WS 5/70

Part No.: **277003**

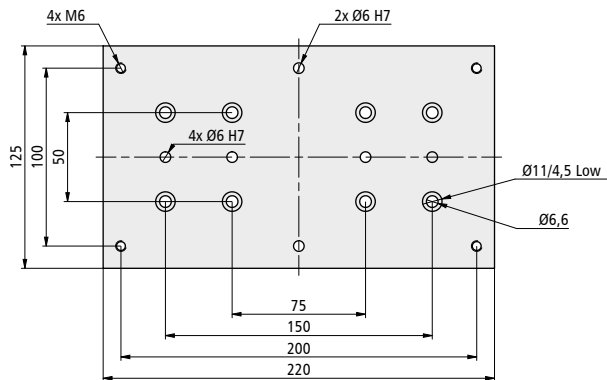

PS 4: L 255 x W 220 x H 7.5 mm

Assembly on: LES 5 with 4 x WS 5/70

Assembly cross table: LES 5 equipped with LES 5 (in connection with VP 2), and fastening option for: connection bracket WV 3 / WV 6

Part No.: **277004**

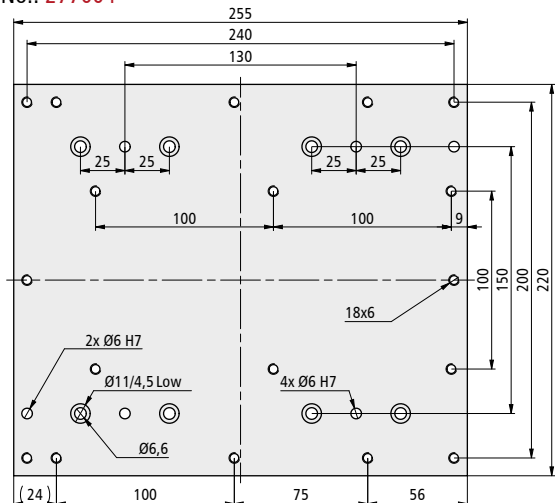

PS 6: L 220 x W 125 x H 7.5 mm

Assembly on: LES 4 with 2 x WS 5/70

Assembly cross table: LES 4 equipped with LES 5 (in connection with PS3), and fastening option for: LES 4 / LES 5

Part No.: **277011**

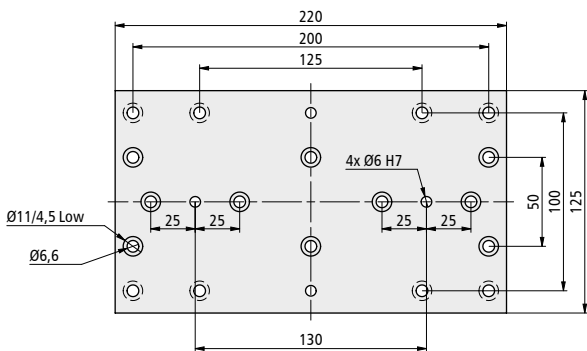

PS 7: L 255 x W 220 x H 7.5 mm

Assembly on: LES 6 equipped with 4 x WS 5/70

Assembly cross table: LES 6 with LES 5 (in connection with PS 4)

Part No.: **277016**

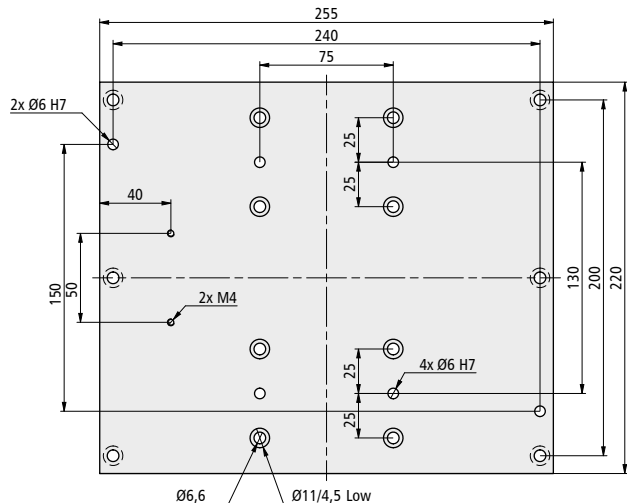



Slide plates PS

PS 8: L 125 x W 145 x H 7.5 mm

Assembly on:
LES 6 with 2 x WS 5/70

Part No.: 277017

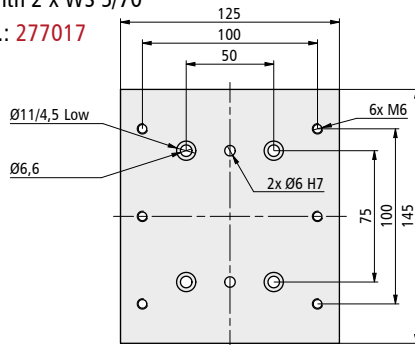

PS 9: L 250 x W 145 x H 7.5 mm

Assembly on: LES 6 with 4 x WS 5/70,
fastening option made for: Connection bracket WV 7

Part No.: 277018

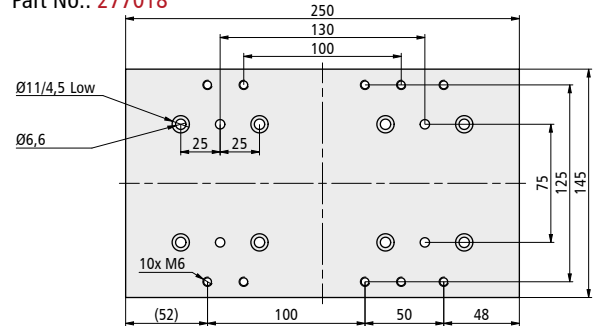

PS 10: L 210 x W 215 x H 7.5 mm

Assembly on: LES 6 with 4 x WS 5/70,
assembly cross table: LES 6 equipped with LES 6
(in connection with PS 11)

Part No.: 277019

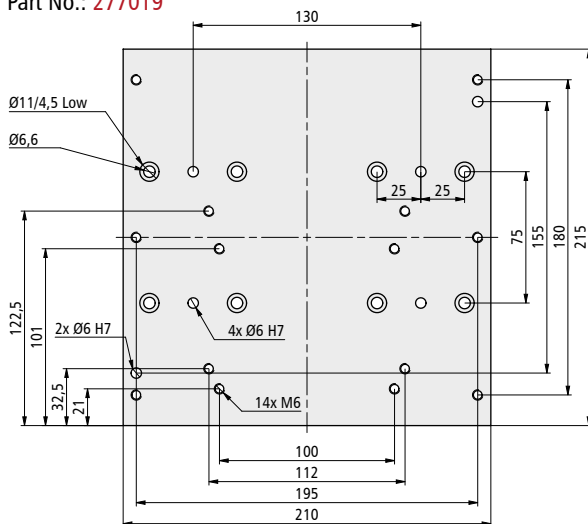

PS 11: L 210 x W 215 x H 7.5 mm

Assembly on: LES 6 with 4 x WS 5/70
assembly cross table: LES 6 equipped with LES 4
(in connection with PS10) fastening option for: LES 6

Part No.: 277020

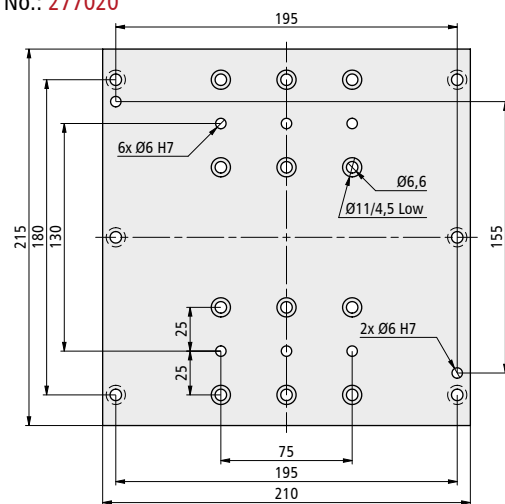

PS 12: L 220 x W 180 x H 7.5 mm

Assembly on: LES 6 with 4 x WS 5/70
fastening option for: LES 5

Part No.: 277021

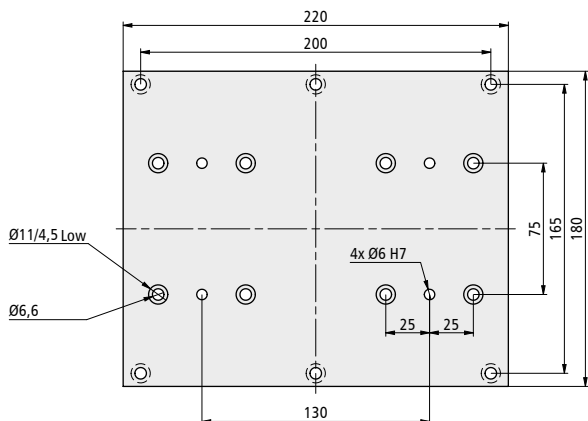

Connection plate VP 2: L 255 x W 220 x H 7.5 mm

Assembly on: LES 5 with 4 x WS 5/70
fastening option for: LES 5

Part No.: 277006

