

Rotary tilting unit

DSH-S



Features

- With precision transmission
 - High load capacity, rigid drive bearing
 - Absence of play and high torsional rigidity
- With rotary unit RDH-S
- Reduction 1:51 or 1:101
- Stepper or servomotor
- Protection class IP 65
- Stainless design
- Transfer accuracy < 1.5 minute of arc
- Repeatability < ± 6 seconds of arc
- No maintenance
- Swivel range continuously variable

For pin assignment see page 2-112

For transport loads, see page 2-113

Ordering key

2 6 5 4 1 X X 0 0 0

Motors

- 0 = Stepper motor MS 045 HT with encoder (400 imp., 3-channel, RS422)
- 2 = brushed DC servomotor RE 40
- 3 = brushless EC servomotor EC 42
- 5 = Stepper motor without encoder

Transmission reduction

- 0 = 1 : 101
- 1 = 1 : 51

Accessories



Chuck assembly
3-jaw chuck \varnothing 65

Part no.: **269060 3065***

3-jaw chuck \varnothing 80

Part no.: **269063 2080***

3-jaw chuck \varnothing 100

Part no.: **269063 2100***

* incl. Flange



Circular plate

\varnothing 150

Part no.: **269 050 0150**

Rotary tilting unit

DSH-S

Technical specification

	stepper motor MS 045 HT *		EC servomotor EC 42		DC servo motor RE 40	
	1:51	1:101	1:51	1:101	1:51	1:101
Reduction ratio	1:51	1:101	1:51	1:101	1:51	1:101
Nominal output speed [1/min]	4	2	22	11	22	11
	at 1500 Hz (225 1/min)		at 1100 1/min		at 1100 1/min	
Max. output speed [1/min]	24	12	59	30	69	35
	at 8000 Hz		--			
Nominal torque [Nm]	7	11	4.8	9.2	4.6	9
	at 1500 Hz		--			
Max. torque (short term) [Nm]	--	--	7	11	7	11
Rated holding torque (static load) [Nm]	7	11	7	11	7	11
Max. transmission load [Nm]	18	28	18	28	18	28
	Limit for repeatable peak torque					
Dynamic load factor C [N]	5800					
Static load factor C ₀ [N]	8600					
Weight [kg]	12 kg					

* Values for half-step operation

Dimensioned drawings

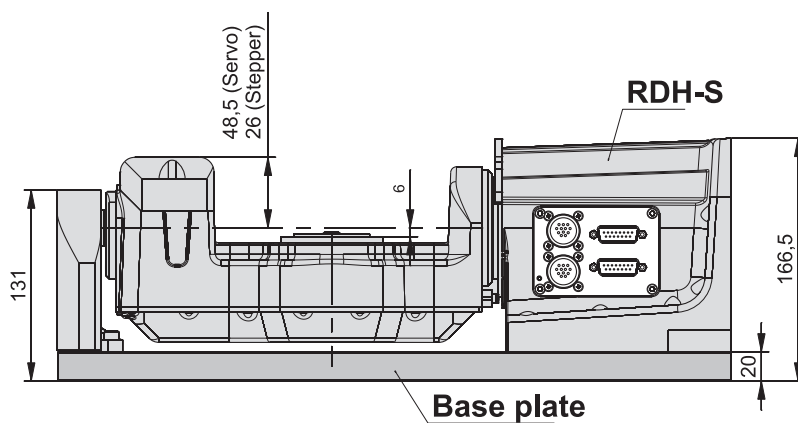

Swivel range
190° / max. 230°

